

DG型中低压锅炉给水泵

DG type low pressure boiler feed pump

➤ **水力部件采用CFD流场分析技术优化设计**
水力部件采用CFD流场分析技术优化设计，高效节能，性能优良

➤ **轴采用优质碳素钢多道热处理工艺**
轴采用优质碳素钢多道热处理工艺，保证热稳定性

➤ **轴承采用衬套式安装结构**
轴承采用衬套式安装结构、加大设计，拆装方便，承载力强，使用寿命长

➤ **平衡盘部件强化设计**
平衡盘部件强化设计，摩擦副用不锈钢淬火处理，耐磨性好，寿命长

➤ **泵级间采用O形圈加金属面密封**
泵级间采用O形圈密封，安装方便，密封可靠

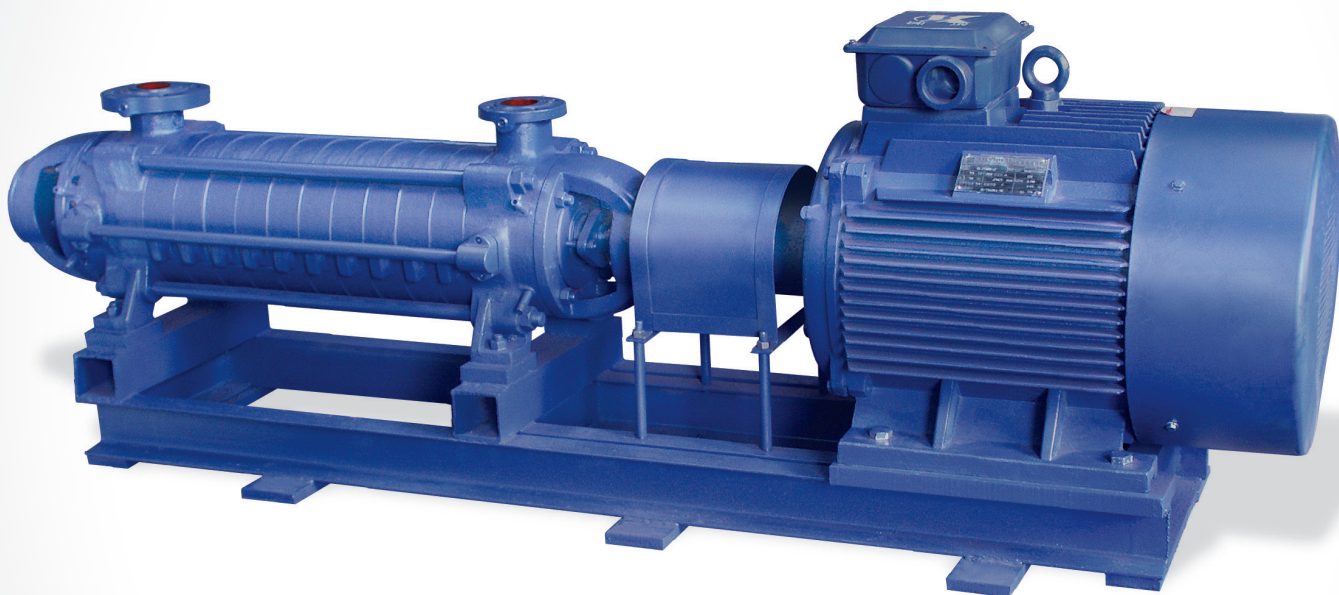

目 录

编写依据：GB 9969.1-1998《工业产品使用说明书总则》

一、产品总述	01
二、典型应用	01
三、工作条件	01
四、型号意义	01
五、电动机	01
六、DG型锅炉给水泵型谱图	02
七、DG型锅炉给水泵结构图	03
八、水泵转向	04
九、泵主要零件选型材料表	04
十、性能曲线说明	05
十一、订货需知	05
十二、技术数据、安装尺寸	06

一、产品总述

DG 系列锅炉给水泵是我公司根据市场需要而开发的系列产品。本产品为单壳体节段式多级离心泵，地脚支撑，用拉紧螺栓将吸入段、中段和吐出段联结成一体。具有以下优点：

- 1 叶轮、导叶等过流部件采用 CFD 流场分析技术优化设计，并采用精密铸造，效率高。
- 2 泵吸入段、中段及吐出段之间的静密封采用金属面密封和“O”形圈双道密封，泵轴封采用高性能苧麻填料或机械密封，安全、可靠。
- 3 装配填料或者机封处配有双重水冷结构的冷却体，有效阻止热量向轴承方向传递。
- 4 转子采用静、动两道平衡工序，严格控制转子跳动，泵运行稳定，振动小。
- 5 轴承采用衬套式安装结构、加大设计，拆装方便承载力强，使用寿命长。
- 6 轴采用优质碳素钢和耐热合金钢经多道热处理工艺，刚度高，稳定性好。
- 7 采用独特的轴肩定位结构，叶轮定位更加可靠，运行安全。

本产品符合 GB/T 5657-1995 <<离心泵技术条件(III)>>标准。

二、典型应用

中低压锅炉给水；冷凝系统；市政供水及增压；工厂供水；高层及住宅群的供水；空调、采暖系统的冷冻、冷却循环系统供水；

三、工作条件

转速：	2950 r/min
液体：	清洁水或理化性能类似于水、不含固体颗粒的液体。
液体温度：	≤105℃；当介质温度≥80℃，必须外接冷却水冷却。
流量范围：	4~185m ³ /h
扬程范围：	46~684 m
最高工作压力：	吸入口压力+泵最大压力≤7MPa

四、型号意义

DG 型锅炉给水泵	DG	46	-50	× 6
泵的流量 (m ³ /h)				
单级扬程 (m)				
级数 (叶轮个数)				

五、电动机

Y 系列三相异步电动机：（可根据客户要求配置）

电压：380V 或 6KV；频率：50Hz；

防护等级：IP44；绝缘等级：B；安装形式：B3

六、型谱图

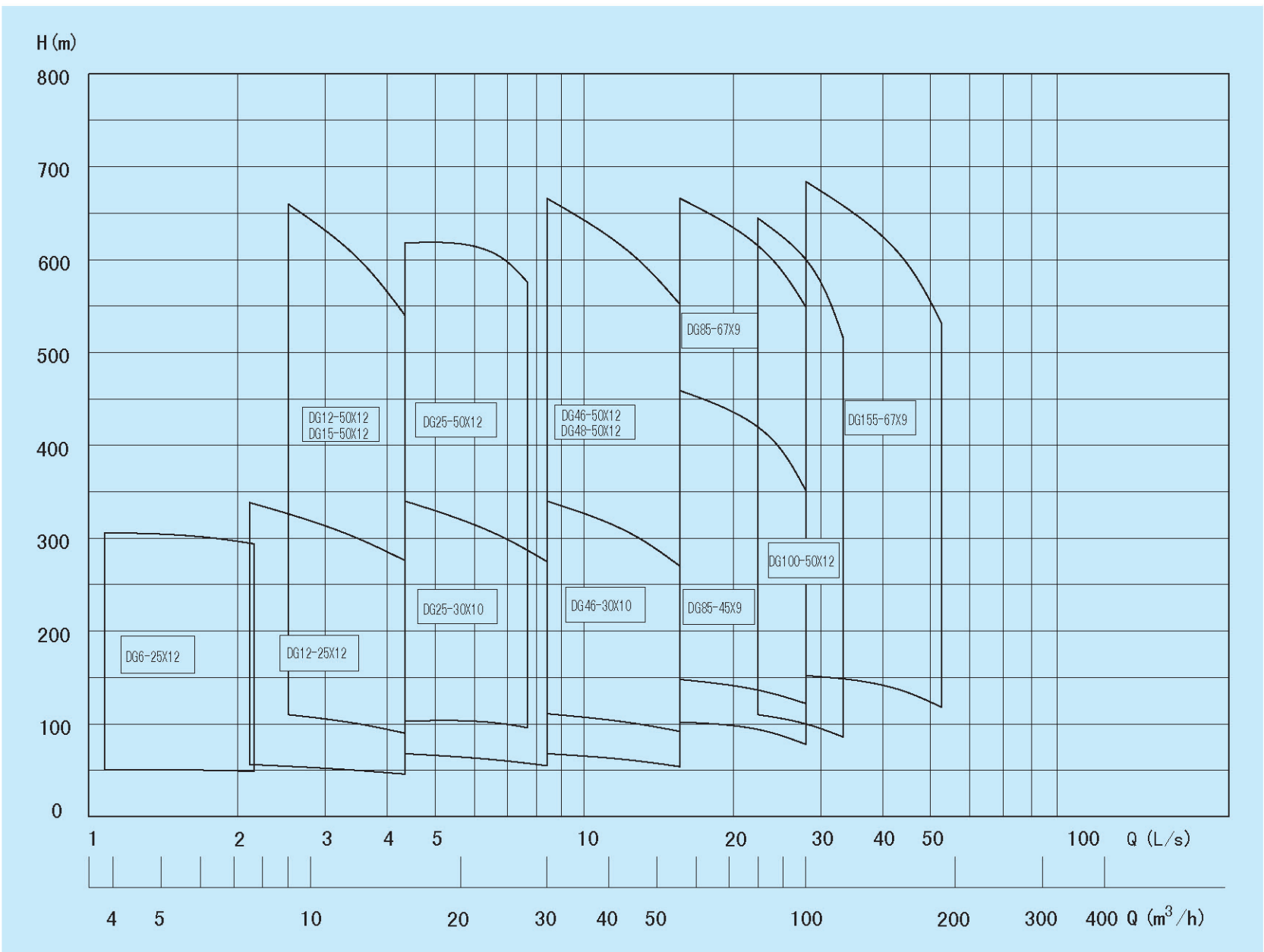

七、结构图

DG型锅炉给水泵结构图

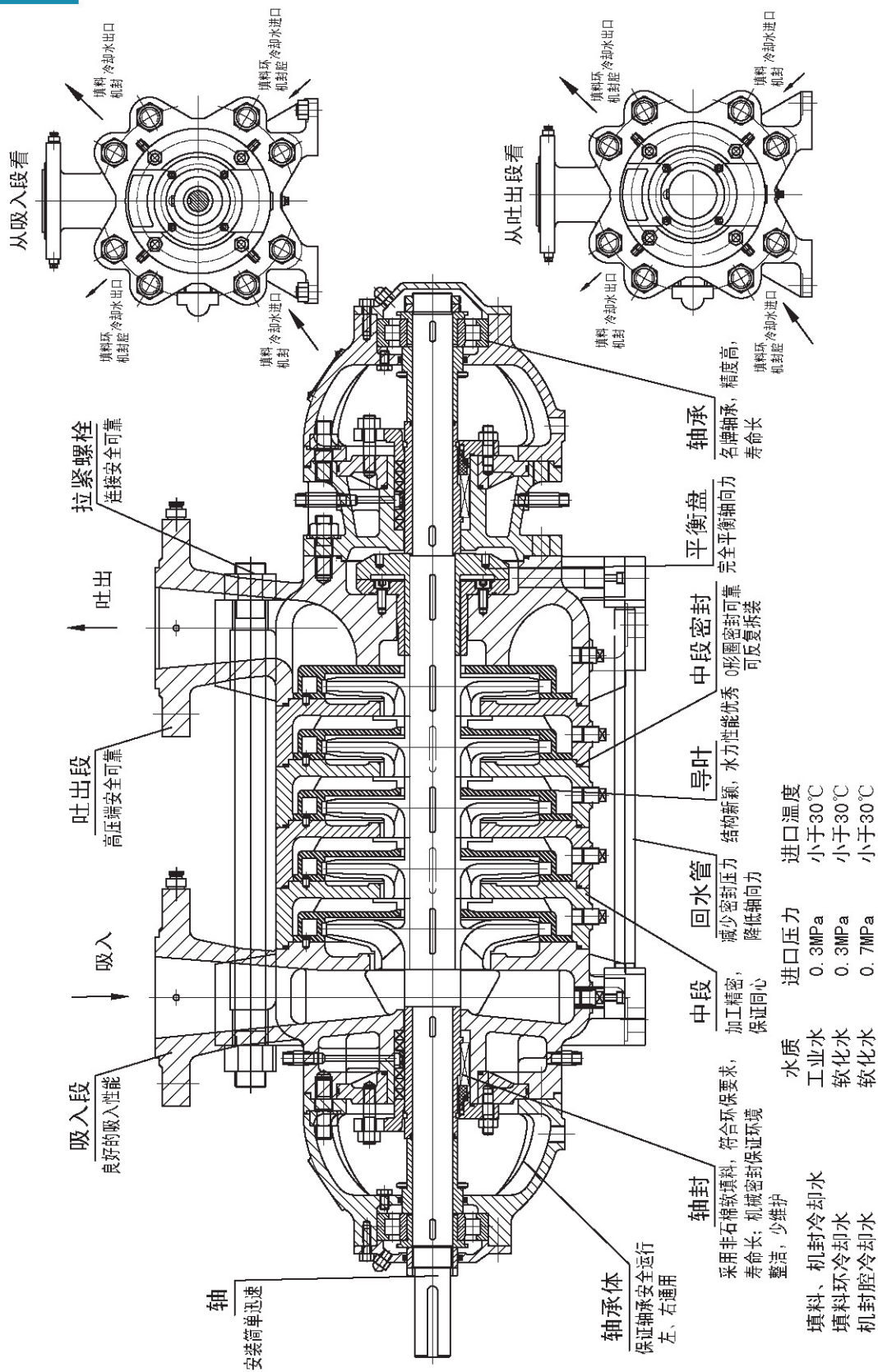

八、水泵转向

标准型从电机端朝泵看，为顺时针方向旋转。

电机在吸入端布置：（标准型）

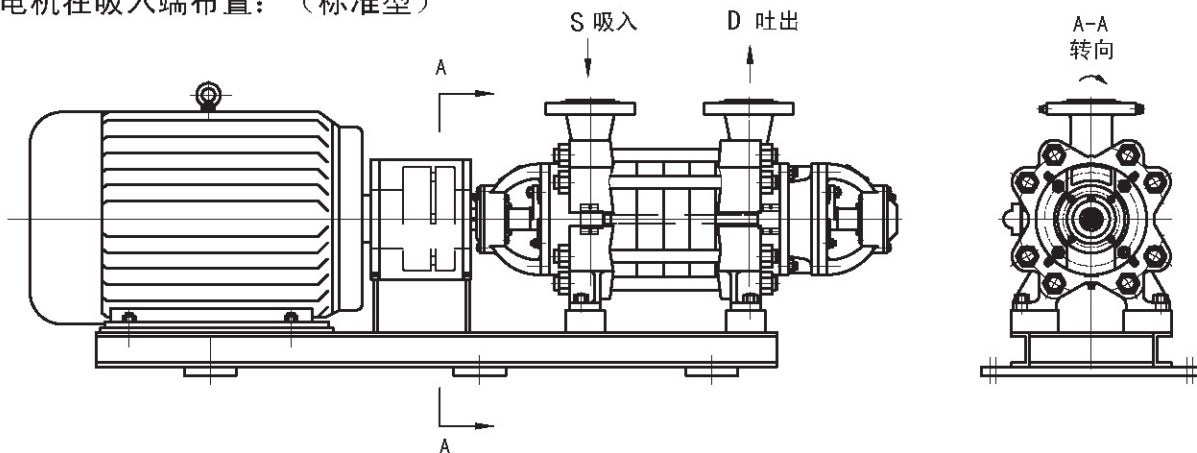

九、泵主要零件选型材料表

名称	材料 (*为标准基本型材料配置)			标准
吸入段	铸铁	HT200	*	GB9439
	球铁	QT500-7		GB1348
	铸钢	ZG230-450		GB11352
吐出段	铸铁	HT250	*	GB9439
	球铁	QT500-7		GB1348
	铸钢	ZG230-450		GB11352
中段	铸铁	HT250	*	GB9439
	球铁	QT500-7		GB1348
	铸钢	ZG230-450		GB11352
导叶	铸铁	HT200	*	GB9439
	球铁	QT500-7		GB1348
	铸钢	ZG230-450		GB11352
叶轮	铸钢	ZG230-450	*	GB11352
轴套	铸钢	ZG310-570	*	GB11352
	不锈钢	2Cr13		GB2100
密封环	铸铁	HT200	*	GB9439
	不锈钢	3Cr13		GB2100
	锡青铜	ZCuSn10Pb1		GB1176
平衡盘	不锈钢	2Cr13	*	GB1220
	球铁	QT500-7		GB1348
平衡环、套	不锈钢	3Cr13	*	GB2100
轴	碳钢	45	*	GB699
	不锈钢	40Cr		GB3077
轴封	填料密封	苕麻	*	
	机械密封	H75		DIN24960
轴承体	铸铁	HT200	*	GB9439

注：单级扬程大于或等于 50m 时，轴采用 40Cr。

十、性能曲线说明

- 1 所有曲线是基于 $3 \times 380V$ 50Hz, 转速为 2950r/min 的换算值。
- 2 测量时水温为 $20^{\circ}C$ 。
- 3 曲线适用于运动粘度 $V=1mm^3/s$

曲线图 1 Q-H 曲线表示各种级数的泵在标准转速下的换算值。

曲线图 2 表示单级性能曲线。

曲线 H 代表： 每级泵的流量扬程关系；

曲线 P 代表： 每级泵的轴功率与流量的关系；

曲线 η 代表： 不考虑电机效率时的泵效率；

曲线 $(NPSH)_r$ 代表： 泵必须汽蚀余量。



图1



图2

十一、订货需知

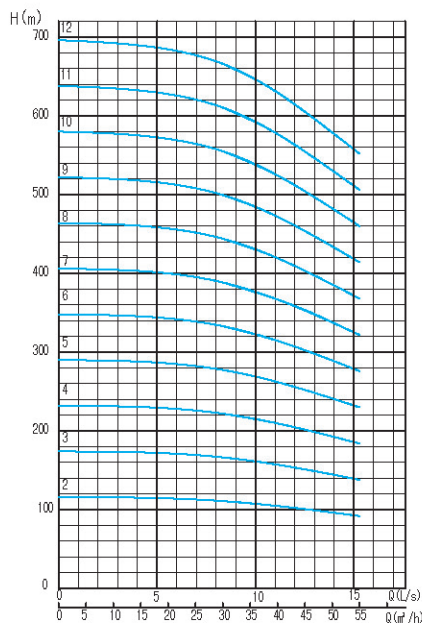
用户订货时，应按下列要求在合同上明确：

- 泵
泵型号
流量 m^3/h (L/s)；扬程 m ；介质温度 $^{\circ}C$ ；
进口压力 m ；轴封形式 填料、机械密封；
材质要求
- 电机
电机型号 电压 V
电机功率 kW ；电机转速 r/min ；
电机防护等级
- 底座
整体底座或单泵底座。（强烈推荐 160KW 以上机组配置带单泵座安装方式）

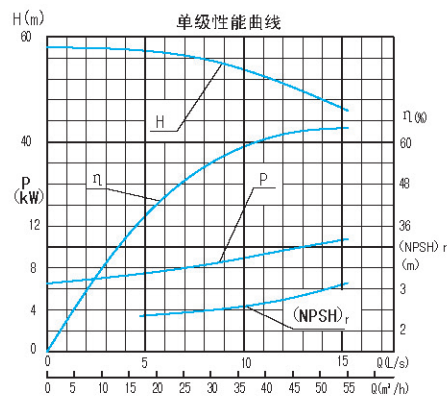
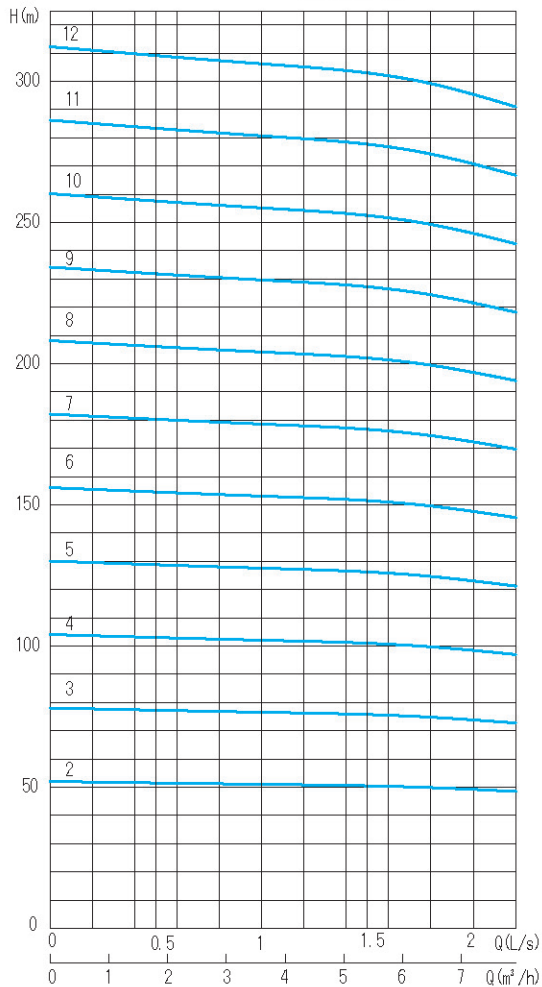
十二、技术数据、安装尺寸
DG6-25 技术数据
DG6-25 x n 性能曲线

DG6-25 x n								
级数 (n)	流量		扬程 (m)	转速 (r/min)	轴功率 (kW)	配用功率 (kW)	效率 (%)	必需汽蚀余量 (m)
	(m³/h)	(L/s)						
2	3.75	1.04	51	2950	1.58	3	33	2.0
	6.3	1.75	50		1.91		45	
	7.5	2.08	49		2.13		47	
3	3.75	1.04	76.5	2950	2.37	5.5	33	2.0
	6.3	1.75	75		2.86		45	
	7.5	2.08	73.5		3.19		47	
4	3.75	1.04	102	2950	3.16	7.5	33	2.0
	6.3	1.75	100		3.81		45	
	7.5	2.08	98		4.26		47	
5	3.75	1.04	127.5	2950	3.94	7.5	33	2.0
	6.3	1.75	125		4.76		45	
	7.5	2.08	122.5		5.32		47	
6	3.75	1.04	153	2950	4.73	11	33	2.0
	6.3	1.75	150		5.72		45	
	7.5	2.08	147		6.39		47	
7	3.75	1.04	178.5	2950	5.52	11	33	2.0
	6.3	1.75	175		6.67		45	
	7.5	2.08	171.5		7.45		47	
8	3.75	1.04	204	2950	6.31	15	33	2.0
	6.3	1.75	200		7.62		45	
	7.5	2.08	196		8.51		47	
9	3.75	1.04	229.5	2950	7.10	15	33	2.0
	6.3	1.75	225		8.58		45	
	7.5	2.08	220.5		9.58		47	
10	3.75	1.04	255	2950	7.89	18.5	33	2.0
	6.3	1.75	250		9.53		45	
	7.5	2.08	245		10.64		47	
11	3.75	1.04	280.5	2950	8.68	18.5	33	2.0
	6.3	1.75	275		10.48		45	
	7.5	2.08	269.5		11.71		47	
12	3.75	1.04	306	2950	9.47	18.5	33	2.0
	6.3	1.75	300		11.43		45	
	7.5	2.08	294		12.77		47	

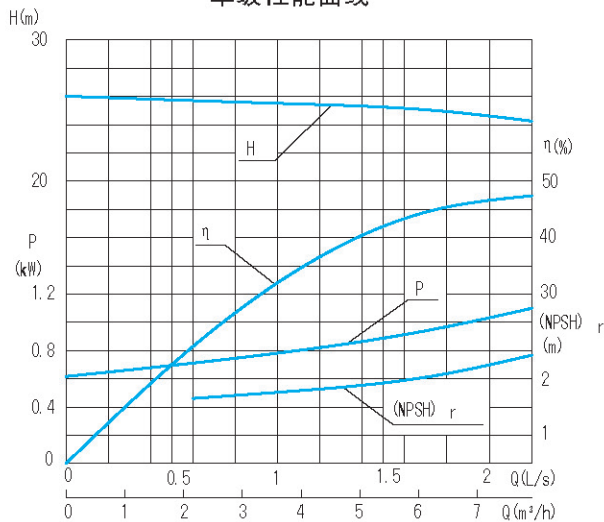
单级性能曲线

DG6-25 安装尺寸

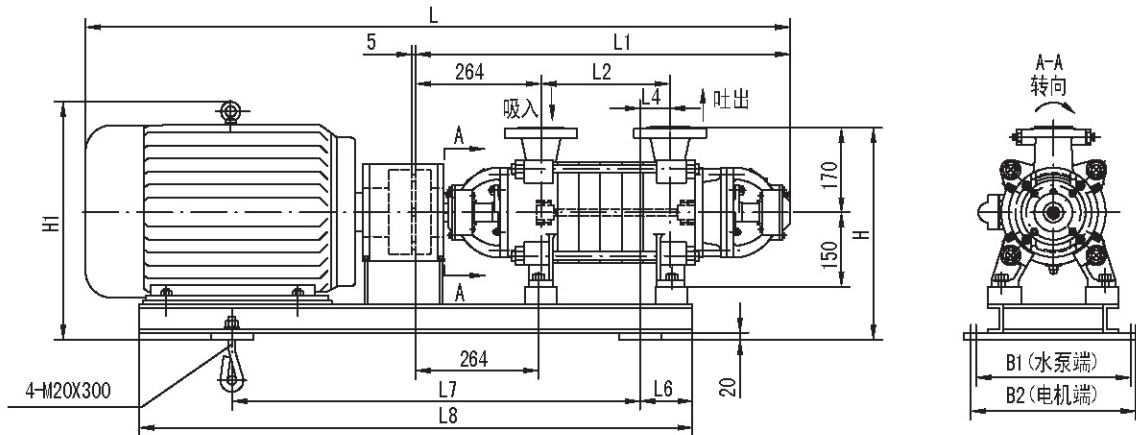

吸入配对法兰 (0.6MPa)

DN40-PN6 RF GB/T9115.1-2000

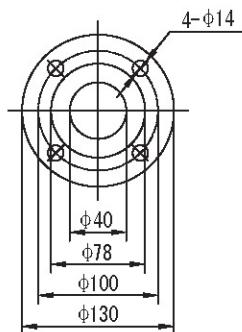

吐出配对法兰 (4.0MPa)

DN40-PN40 F GB/T9115.2-2000

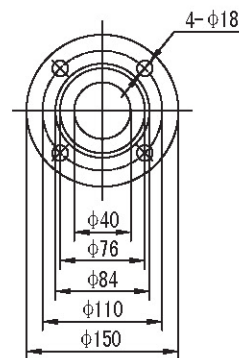

泵型号	泵级数	尺寸 mm										电动机		泵重kg	
		L	L1	L2	L4	L6	L7	L8	H	H1	B1	B2	型号		kW
DG6-25	2	1021	636	130	76	110	550	720	405	380	390	390	Y100L-2	3	75
	3	1166	686	180	86	130	550	845	405	418	390	390	Y132S ₁ -2	5.5	85
	4	1216	736	230	96	140	600	905	405	418	390	390	Y132S ₂ -2	7.5	95
	5	1266	786	280	136	170	600	935	405	418	390	390	Y132S ₂ -2	7.5	105
	6	1441	836	330	135	170	735	1100	415	470	435	435	Y160M ₁ -2	11	115
	7	1491	886	380	185	225	735	1155	415	470	435	435	Y160M ₁ -2	11	125
	8	1541	936	430	185	230	785	1210	415	470	435	435	Y160M ₂ -2	15	135
	9	1591	986	480	235	270	785	1250	415	470	435	435	Y160M ₂ -2	15	145
	10	1686	1036	530	220	250	885	1345	415	470	435	435	Y160L-2	18.5	155
	11	1736	1086	580	265	295	885	1390	415	470	435	435	Y160L-2	18.5	165
	12	1786	1136	630	315	345	885	1440	415	470	435	435	Y160L-2	18.5	175

DG12-25 技术数据

DG6-25 x n 性能曲线

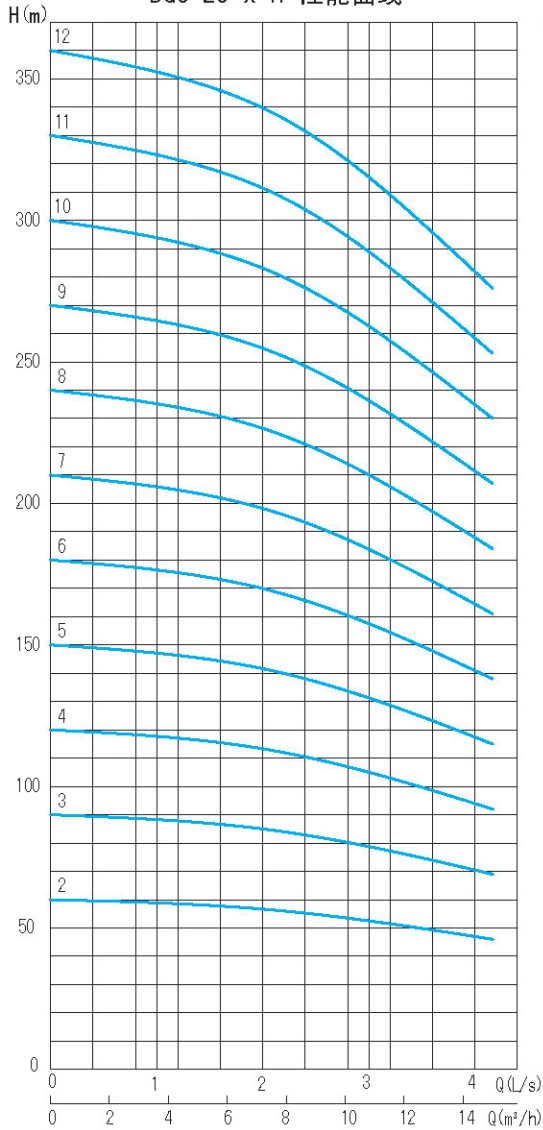

DG12-25×n								
级数	流量		扬程	转速	轴功率	配用功率	效率	必需汽蚀余量
(n)	(m³/h)	(L/s)	(m)	(r/min)	(kW)	(kW)	(%)	(m)
2	7.5	2.08	56.4	2950	2.62	5.5	44	2.0
	12.5	3.47	50		3.15		54	
	15	4.17	46		3.54		53	
3	7.5	2.08	84.6	2950	3.93	7.5	44	2.0
	12.5	3.47	75		4.73		54	
	15	4.17	69		5.32		53	
4	7.5	2.08	112.8	2950	5.23	11	44	2.0
	12.5	3.47	100		6.30		54	
	15	4.17	92		7.09		53	
5	7.5	2.08	141	2950	6.54	11	44	2.0
	12.5	3.47	125		7.88		54	
	15	4.17	115		8.86		53	
6	7.5	2.08	169.2	2950	7.85	15	44	2.0
	12.5	3.47	150		9.45		54	
	15	4.17	138		10.63		53	
7	7.5	2.08	197.4	2950	9.16	15	44	2.0
	12.5	3.47	175		11.03		54	
	15	4.17	161		12.40		53	
8	7.5	2.08	225.6	2950	10.47	18.5	44	2.0
	12.5	3.47	200		12.60		54	
	15	4.17	184		14.18		53	
9	7.5	2.08	253.8	2950	11.78	18.5	44	2.0
	12.5	3.47	225		14.18		54	
	15	4.17	207		15.95		53	
10	7.5	2.08	282	2950	13.09	22	44	2.0
	12.5	3.47	250		15.75		54	
	15	4.17	230		17.72		53	
11	7.5	2.08	310.2	2950	14.39	22	44	2.0
	12.5	3.47	275		17.33		54	
	15	4.17	253		19.49		53	
12	7.5	2.08	338.4	2950	15.70	30	44	2.0
	12.5	3.47	300		18.90		54	
	15	4.17	276		21.26		53	

单级性能曲线

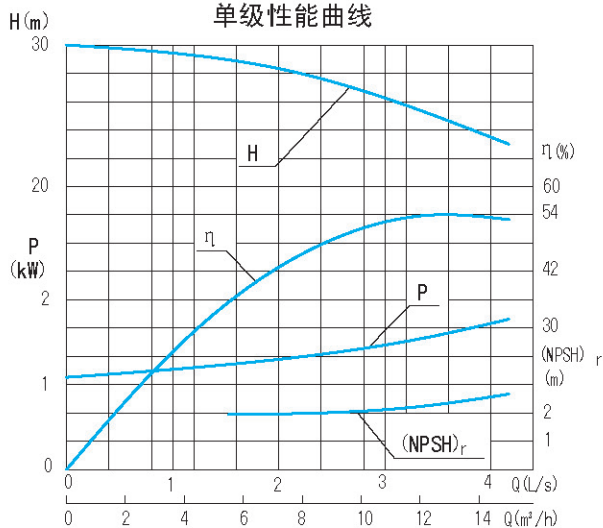

DG12-25 安装尺寸

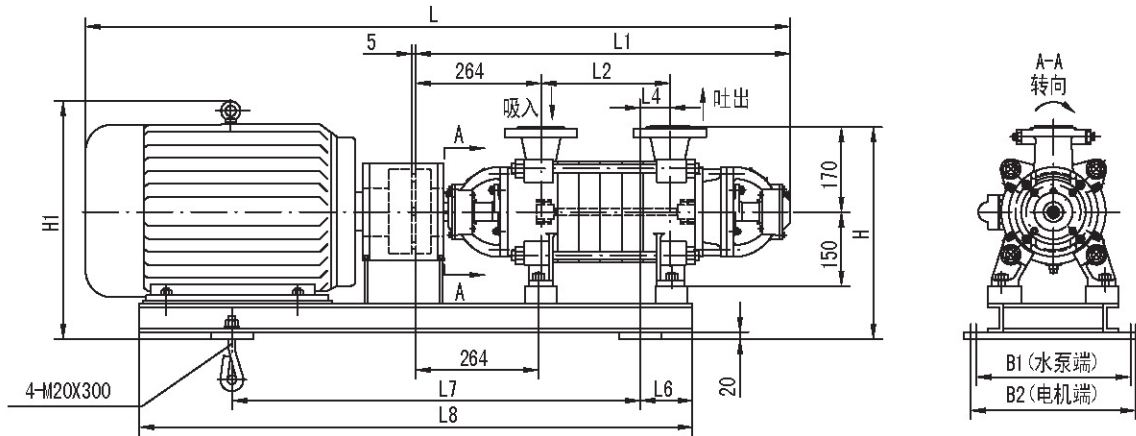

吸入配对法兰 (0.6MPa)

DN50-PN6 RF GB/T9115.1-2000

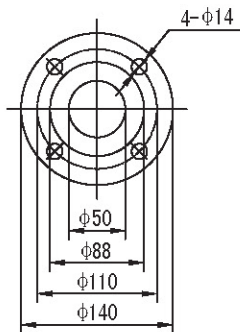

吐出配对法兰 (4.0MPa)

DN40-PN40 F GB/T9115.2-2000

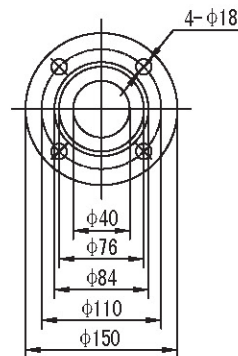

泵型号	泵级数	尺寸 mm											电动机		泵重 kg
		L	L1	L2	L4	L6	L7	L8	H	H1	B1	B2	型号	kW	
DG12-25	2	1116	636	130	59	95	580	785	405	418	395	395	Y132S ₁ -2	5.5	102
	3	1166	686	180	89	125	600	835	405	418	395	395	Y132S ₂ -2	7.5	115
	4	1341	736	230	114	150	660	1005	415	470	430	430	Y160M ₁ -2	11	128
	5	1391	786	280	145	175	680	1050	415	470	430	430	Y160M ₁ -2	11	140
	6	1441	836	330	185	215	690	1100	415	470	430	430	Y160M ₂ -2	15	153
	7	1491	886	380	195	225	730	1150	415	470	430	430	Y160M ₂ -2	15	166
	8	1586	936	430	220	250	780	1245	415	470	430	430	Y160L-2	18.5	180
	9	1636	986	480	250	280	800	1295	415	470	430	430	Y160L-2	18.5	193
	10	1711	1036	530	280	310	820	1350	448	528	460	460	Y180M-2	22	204
	11	1761	1086	580	300	330	850	1400	448	528	460	460	Y180M-2	22	217
	12	1916	1136	630	325	355	930	1530	468	573	500	500	Y200L ₁ -2	30	239

DG12-50 技术数据

DG12-50 x n 性能曲线

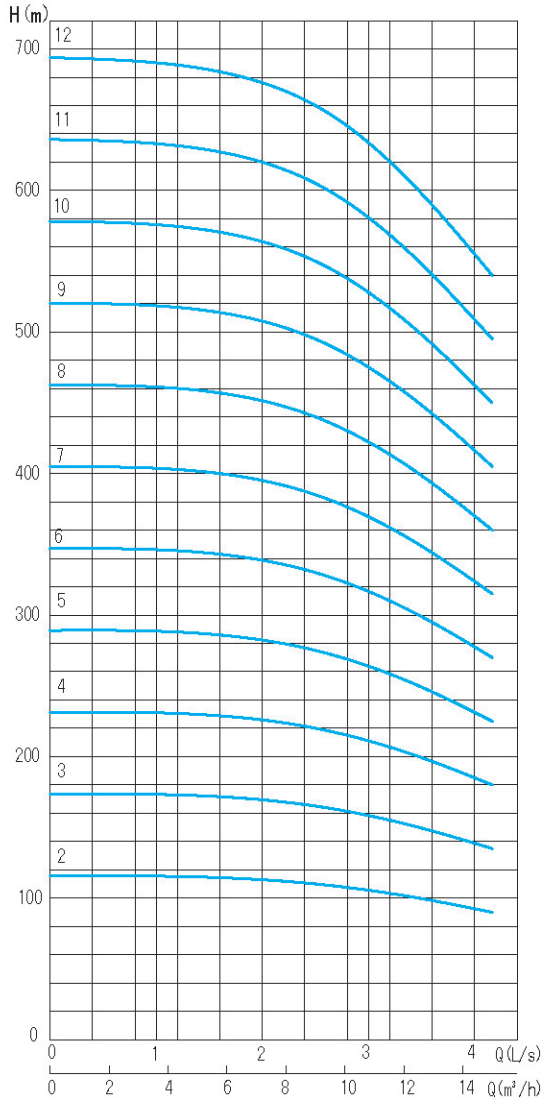

DG12-50×n								
级数	流量		扬程	转速	轴功率	配用功率	效率	必需汽蚀余量
(n)	(m^3/h)	(L/s)	(m)	(r/min)	(kW)	(kW)	(%)	(m)
2	9	2.5	110	2950	7.81	15	34.5	2.0
	12.5	3.47	100		8.51		40	2.2
	15	4.17	90		8.96		41	2.7
3	9	2.5	165	2950	11.72	18.5	34.5	2.0
	12.5	3.47	150		12.76		40	2.2
	15	4.17	135		13.45		41	2.7
4	9	2.5	220	2950	15.62	22	34.5	2.0
	12.5	3.47	200		17.01		40	2.2
	15	4.17	180		17.93		41	2.7
5	9	2.5	275	2950	19.53	30	34.5	2.0
	12.5	3.47	250		21.27		40	2.2
	15	4.17	225		22.41		41	2.7
6	9	2.5	330	2950	23.43	30	34.5	2.0
	12.5	3.47	300		25.52		40	2.2
	15	4.17	270		26.89		41	2.7
7	9	2.5	385	2950	27.34	37	34.5	2.0
	12.5	3.47	350		29.77		40	2.2
	15	4.17	315		31.37		41	2.7
8	9	2.5	440	2950	31.25	45	34.5	2.0
	12.5	3.47	400		34.03		40	2.2
	15	4.17	360		35.85		41	2.7
9	9	2.5	495	2950	35.15	45	34.5	2.0
	12.5	3.47	450		38.28		40	2.2
	15	4.17	405		40.34		41	2.7
10	9	2.5	550	2950	39.06	55	34.5	2.0
	12.5	3.47	500		42.53		40	2.2
	15	4.17	450		44.82		41	2.7
11	9	2.5	605	2950	42.96	55	34.5	2.0
	12.5	3.47	550		46.79		40	2.2
	15	4.17	495		49.30		41	2.7
12	9	2.5	660	2950	46.87	75	34.5	2.0
	12.5	3.47	600		51.04		40	2.2
	15	4.17	540		53.78		41	2.7

单级性能曲线

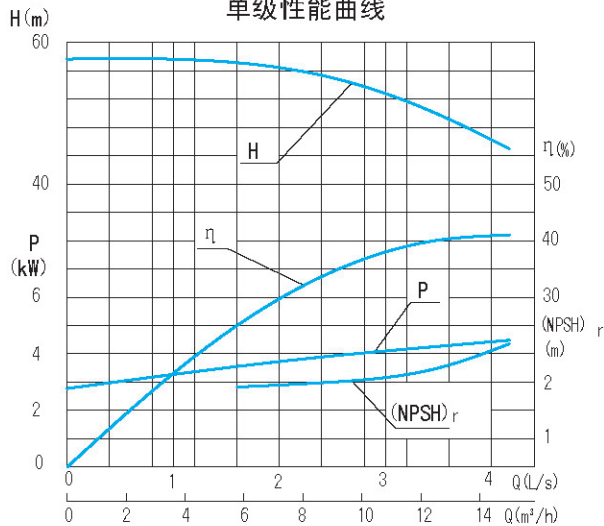

DG12-50 安装尺寸

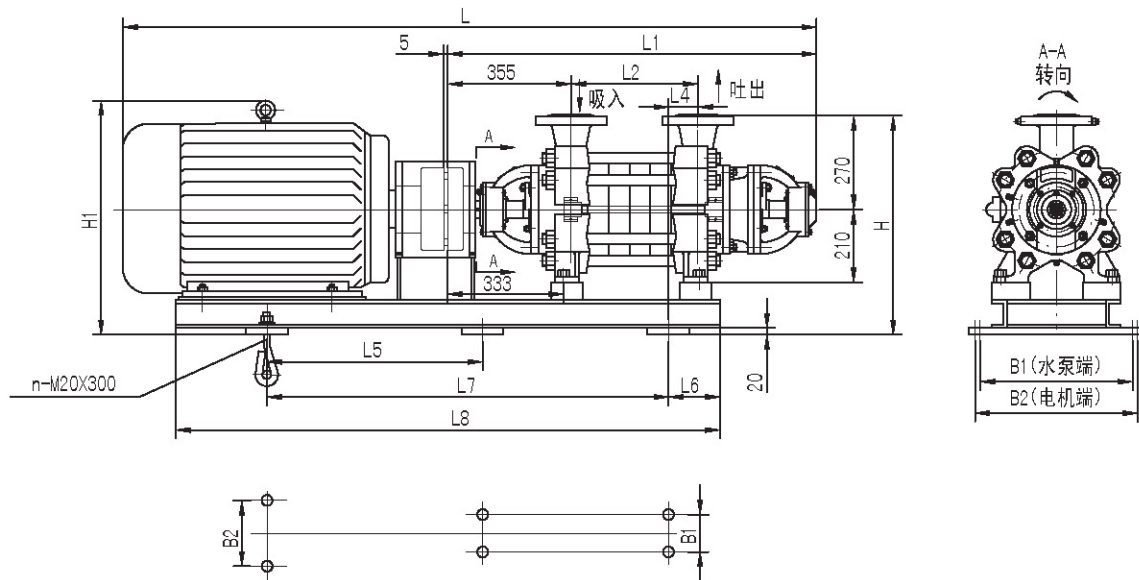

吸入、吐出配对法兰(6.3MPa)

DN65-PN63 F GB/T9115.2-2000

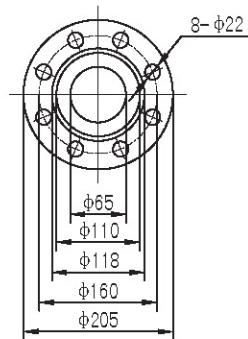

泵型号	泵级数	尺寸 mm											电动机		泵重 kg		
		L	L1	L2	L4	L5	L6	L7	L8	H	H1	B1	B2	n		型号	kW
DG12-50	2	1486	881	185	77		110	750	1041	580	535	470	470	4	Y160M ₂ -2	15	200
	3	1591	941	245	107		140	805	1145	580	535	470	470	4	Y160L-2	18.5	225
	4	1676	1001	305	142		175	830	1210	580	560	470	470	4	Y180M-2	22	250
	5	1841	1061	365	167		200	910	1352	617	622	470	470	4	Y200L ₁ -2	30	275
	6	1901	1121	425	197		230	940	1412	617	622	470	470	4	Y200L ₁ -2	30	300
	7	1961	1181	485	227		260	970	1472	617	622	470	470	4	Y200L ₂ -2	37	325
	8	2061	1241	545	264		297	1020	1553	630	665	530	530	4	Y225M-2	45	350
	9	2121	1301	605	294		327	1050	1613	630	665	530	530	4	Y225M-2	45	375
	10	2296	1361	665	319	520	352	1145	1772	660	715	510	570	6	Y250M-2	55	400
	11	2356	1421	725	349	535	382	1175	1832	660	715	510	570	6	Y250M-2	55	425
	12	2486	1481	785	379	620	412	1235	1962	690	780	510	640	6	Y280S-2	75	450

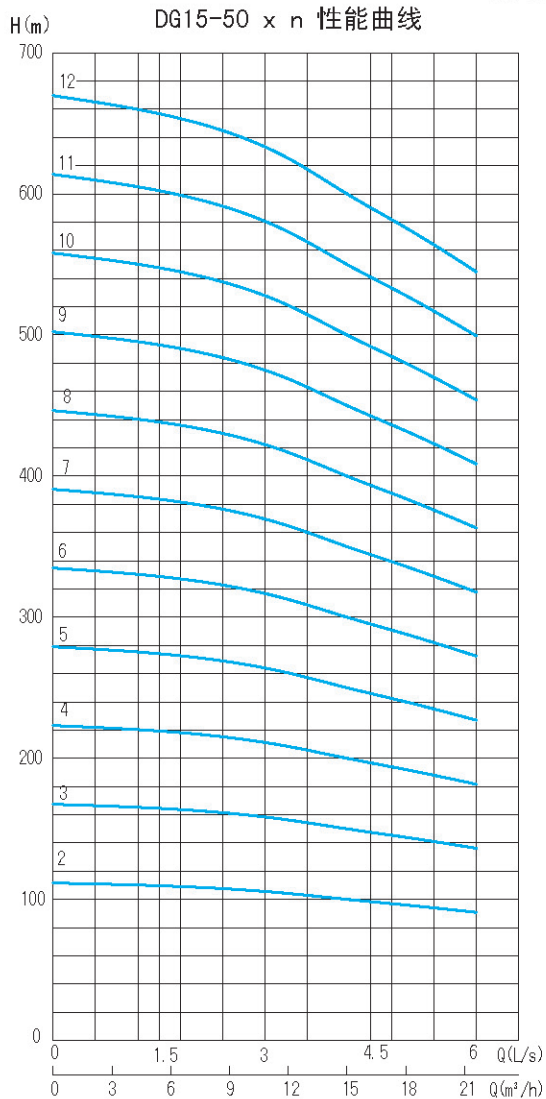
DG15-50 技术数据

DG15-50 X n								
级数	流量		扬程	转速	轴功率	配用功率	效率	必需汽蚀余量
(n)	(m ³ /h)	(L/s)	(m)	(r/min)	(kW)	(kW)	(%)	(m)
2	12	3.33	104	2950	7.23	15	47	2.0
	15	4.16	100		8.17		50	2.2
	18	5	96		9.22		51	2.7
3	12	3.33	156	2950	10.84	18.5	47	2.0
	15	4.16	150		12.25		50	2.2
	18	5	144		13.84		51	2.7
4	12	3.33	208	2950	14.46	22	47	2.0
	15	4.16	200		16.33		50	2.2
	18	5	192		18.45		51	2.7
5	12	3.33	261	2950	18.14	30	47	2.0
	15	4.16	250		20.42		50	2.2
	18	5	240		23.06		51	2.7
6	12	3.33	313	2950	21.75	30	47	2.0
	15	4.16	300		24.50		50	2.2
	18	5	288		27.67		51	2.7
7	12	3.33	365	2950	25.37	37	47	2.0
	15	4.16	350		28.58		50	2.2
	18	5	336		32.28		51	2.7
8	12	3.33	417	2950	28.98	45	47	2.0
	15	4.16	400		32.67		50	2.2
	18	5	384		36.89		51	2.7
9	12	3.33	469	2950	32.60	45	47	2.0
	15	4.16	450		36.75		50	2.2
	18	5	432		41.51		51	2.7
10	12	3.33	521	2950	36.21	55	47	2.0
	15	4.16	500		40.83		50	2.2
	18	5	480		46.12		51	2.7
11	12	3.33	573	2950	39.83	55	47	2.0
	15	4.16	550		44.92		50	2.2
	18	5	528		50.73		51	2.7
12	12	3.33	625	2950	43.44	75	47	2.0
	15	4.16	600		49.00		50	2.2
	18	5	576		55.34		51	2.7

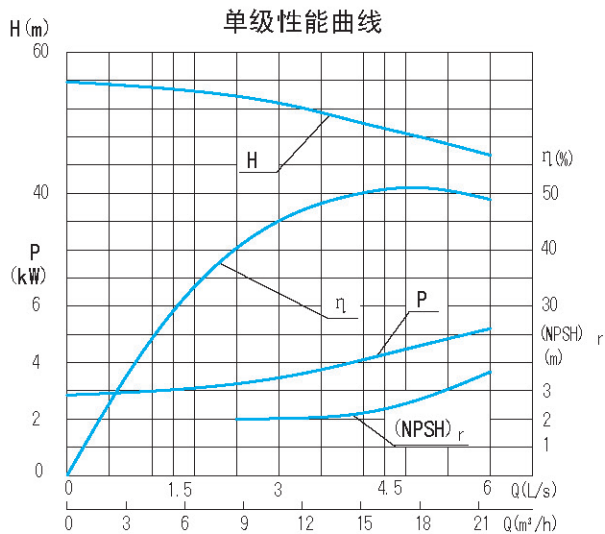

DG15-50 安装尺寸

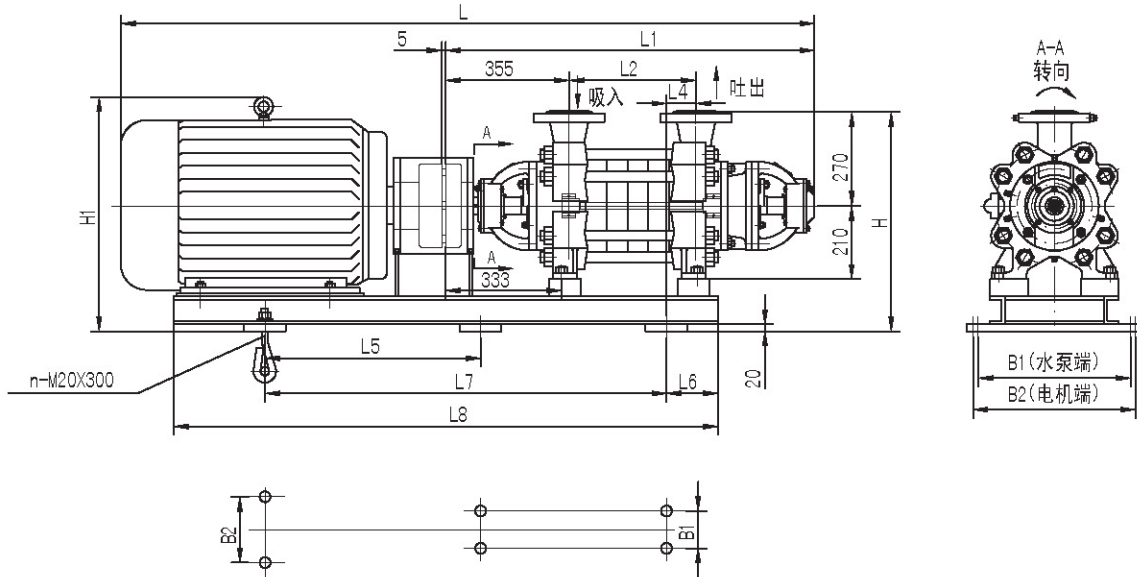

吸入、吐出配对法兰(6.3MPa)

DN65-PN63 F GB/T9115.2-2000

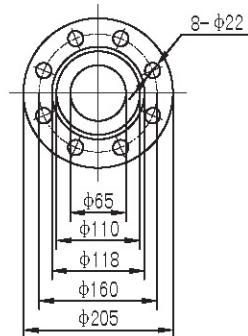

泵型号	泵级数	尺寸 mm										电动机		泵重 kg			
		L	L1	L2	L4	L5	L6	L7	L8	H	H1	B1	B2		n	型号	kW
DG15-50	2	1486	881	185	77		110	750	1041	580	535	470	470	4	Y160M ₂ -2	15	200
	3	1591	941	245	107		140	805	1145	580	535	470	470	4	Y160L-2	18.5	225
	4	1676	1001	305	142		175	830	1210	580	560	470	470	4	Y180M-2	22	250
	5	1841	1061	365	167		200	910	1352	617	622	470	470	4	Y200L ₁ -2	30	275
	6	1901	1121	425	197		230	940	1412	617	622	470	470	4	Y200L ₁ -2	30	300
	7	1961	1181	485	227		260	970	1472	617	622	470	470	4	Y200L ₂ -2	37	325
	8	2061	1241	545	264		297	1020	1553	630	665	530	530	4	Y225M-2	45	350
	9	2121	1301	605	294		327	1050	1613	630	665	530	530	4	Y225M-2	45	375
	10	2296	1361	665	319	520	352	1145	1772	660	715	510	570	6	Y250M-2	55	400
	11	2356	1421	725	349	535	382	1175	1832	660	715	510	570	6	Y250M-2	55	425
	12	2486	1481	785	379	620	412	1235	1962	690	780	510	640	6	Y280S-2	75	450

DG25-30 技术数据

DG25-30 x n 性能曲线

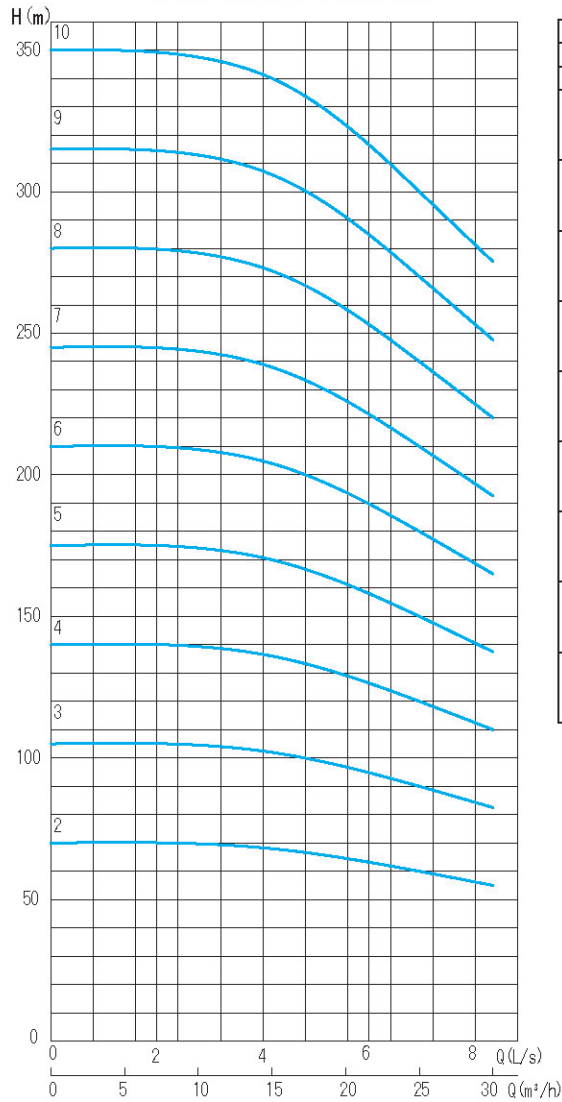

DG25-30×n								
级数	流量		扬程	转速	轴功率	配用功率	效率	必需汽蚀余量
(n)	(m^3/h)	(L/s)	(m)	(r/min)	(kW)	(kW)	(%)	(m)
2	15	4.17	68	2950	5.55	11	50	2.2
	25	6.94	60		6.59		62	
	30	8.33	55		7.13		63	
3	15	4.17	102	2950	8.33	15	50	2.2
	25	6.94	90		9.88		62	
	30	8.33	82.5		10.69		63	
4	15	4.17	136	2950	11.11	18.5	50	2.2
	25	6.94	120		13.17		62	
	30	8.33	110		14.26		63	
5	15	4.17	170	2950	13.88	22	50	2.2
	25	6.94	150		16.47		62	
	30	8.33	137.5		17.82		63	
6	15	4.17	204	2950	16.66	30	50	2.2
	25	6.94	180		19.76		62	
	30	8.33	165		21.39		63	
7	15	4.17	238	2950	19.44	30	50	2.2
	25	6.94	210		23.05		62	
	30	8.33	192.5		24.95		63	
8	15	4.17	272	2950	22.21	37	50	2.2
	25	6.94	240		26.34		62	
	30	8.33	220		28.52		63	
9	15	4.17	306	2950	24.99	37	50	2.2
	25	6.94	270		29.64		62	
	30	8.33	247.5		32.08		63	
10	15	4.17	340	2950	27.77	45	50	2.2
	25	6.94	300		32.93		62	
	30	8.33	275		35.65		63	

单级性能曲线

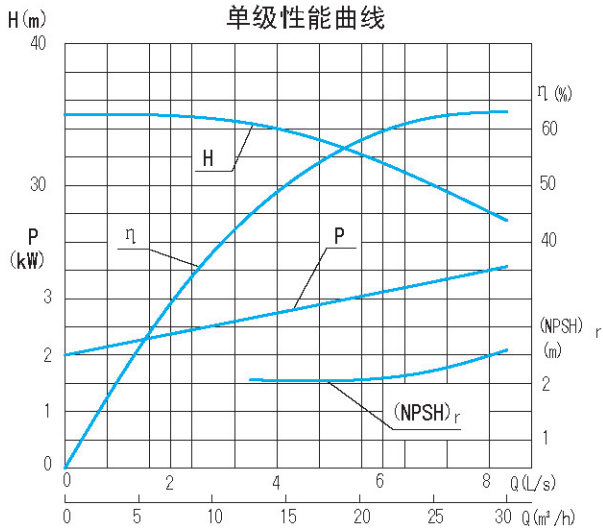

DG25-30 安装尺寸

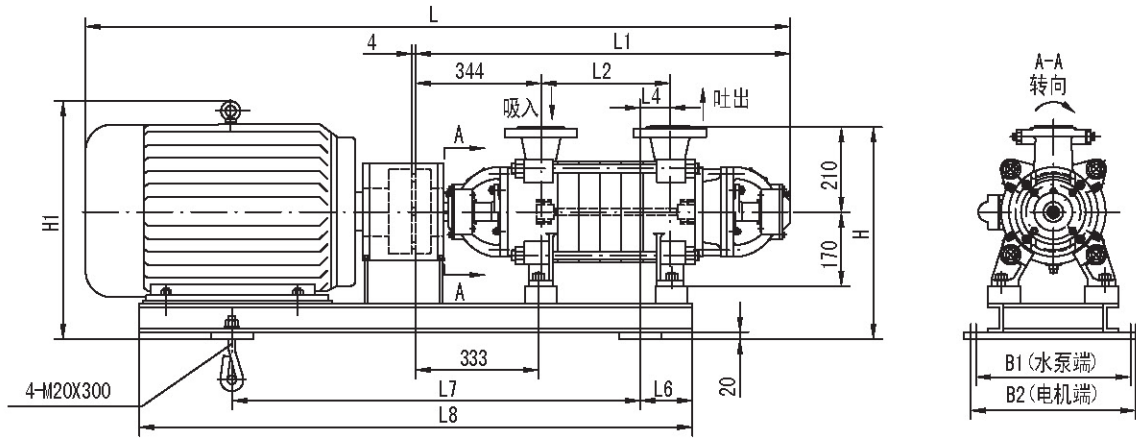

吸入配对法兰 (0.6MPa)

DN65-PN6 RF GB/T9115.1-2000

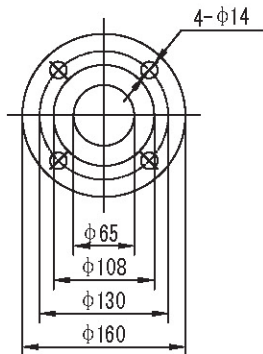

吐出配对法兰 (4.0MPa)

DN65-PN40 F GB/T9115.2-2000

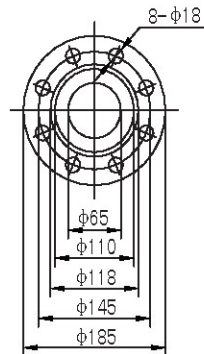

泵型号	泵级数	尺寸 mm										电动机		泵重kg	
		L	L1	L2	L4	L6	L7	L8	H	H1	B1	B2	型号		kW
DG25-30	2	1412	808	165	70	116	770	1032	470	485	440	440	Y160M ₁ -2	11	165
	3	1477	873	230	70	116	835	1097	470	485	440	440	Y160M ₂ -2	15	180
	4	1587	938	295	135	181	835	1206	470	485	440	440	Y160L-2	18.5	195
	5	1677	1003	360	175	221	890	1277	488	528	440	440	Y180M-2	22	210
	6	1847	1068	425	210	256	965	1423	508	573	440	440	Y200L ₁ -2	30	225
	7	1912	1133	490	210	256	1030	1488	508	573	440	440	Y200L ₁ -2	30	240
	8	1977	1198	555	305	351	996	1553	545	610	450	450	Y200L ₂ -2	37	255
	9	2042	1263	620	305	351	1061	1618	545	610	450	450	Y200L ₂ -2	37	270
	10	2147	1328	685	358	404	1031	1711	570	665	450	450	Y225M-2	45	285

DG25-50 技术数据

DG25-50 x n 性能曲线

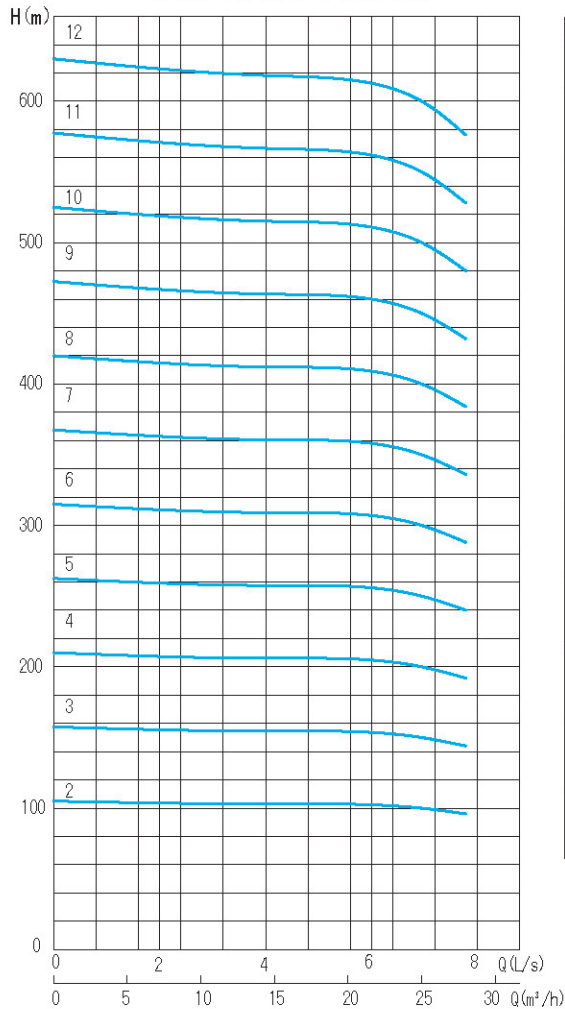

DG25-50 × n								
级数	流量		扬程	转速	轴功率	配用功率	效率	必需汽蚀余量
(n)	(m^3/h)	(L/s)	(m)	(r/min)	(kW)	(kW)	(%)	(m)
2	15	4.16	103	2950	9.56	18.5	44	2.4
	25	6.94	100		12.60		54	2.7
	28	7.78	96		13.55		54	2.8
3	15	4.16	154.5	2950	14.34	22	44	2.4
	25	6.94	150		18.90		54	2.7
	28	7.78	144		20.33		54	2.8
4	15	4.16	206	2950	19.12	30	44	2.4
	25	6.94	200		25.21		54	2.7
	28	7.78	192		27.10		54	2.8
5	15	4.16	257.5	2950	23.90	37	44	2.4
	25	6.94	250		31.51		54	2.7
	28	7.78	240		33.88		54	2.8
6	15	4.16	309	2950	28.68	45	44	2.4
	25	6.94	300		37.81		54	2.7
	28	7.78	288		40.65		54	2.8
7	15	4.16	360.5	2950	33.46	55	44	2.4
	25	6.94	350		44.11		54	2.7
	28	7.78	336		47.43		54	2.8
8	15	4.16	412	2950	38.23	75	44	2.4
	25	6.94	400		50.41		54	2.7
	28	7.78	384		54.20		54	2.8
9	15	4.16	463.5	2950	43.01	75	44	2.4
	25	6.94	450		56.71		54	2.7
	28	7.78	432		60.98		54	2.8
10	15	4.16	515	2950	47.79	75	44	2.4
	25	6.94	500		63.01		54	2.7
	28	7.78	480		67.75		54	2.8
11	15	4.16	566	2950	52.53	90	44	2.4
	25	6.94	550		69.32		54	2.7
	28	7.78	528		74.53		54	2.8
12	15	4.16	618	2950	57.35	90	44	2.4
	25	6.94	600		75.62		54	2.7
	28	7.78	576		81.30		54	2.8

单级性能曲线

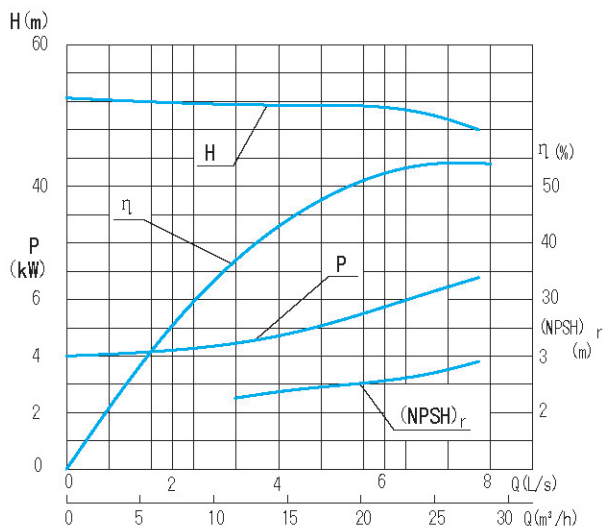

DG25-50 安装尺寸

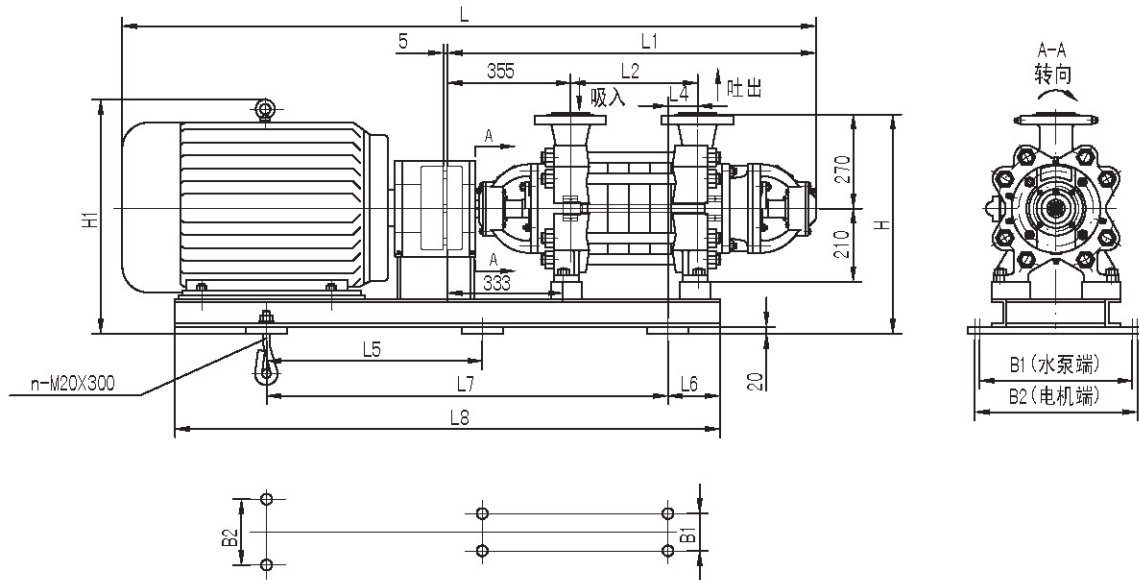

吸入、吐出配对法兰 (6.3MPa)

DN65-PN63 F GB/T9115.2-2000

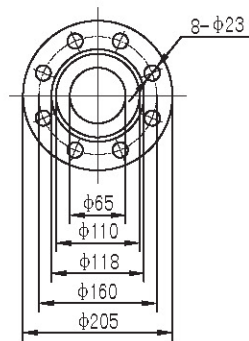

泵型号	泵级数	尺寸 mm												电动机		泵重kg	
		L	L1	L2	L4	L5	L6	L7	L8	H	H1	B1	B2	n	型号		kW
DG25-50	2	1531	881	185	162		195	745	1085	580	535	435	380	4	Y160L-2	18.5	200
	3	1616	941	245	117		150	840	1150	580	560	490	490	4	Y180M-2	22	225
	4	1781	1001	305	174		207	905	1292	580	585	500	500	4	Y200L ₁ -2	30	250
	5	1841	1061	365	204		237	935	1352	617	622	510	510	4	Y200L ₂ -2	37	275
	6	1941	1121	425	220		253	985	1433	630	665	540	540	4	Y225M-2	45	300
	7	2116	1181	485	254	540	287	1075	1592	660	715	490	550	6	Y250M-2	55	325
	8	2246	1241	545	281	675	314	1140	1722	690	780	490	650	6	Y280S-2	75	350
	9	2306	1301	605	311	690	344	1170	1782	690	780	490	650	6	Y280S-2	75	375
	10	2366	1361	665	341	705	374	1200	1842	690	780	490	650	6	Y280S-2	75	400
	11	2476	1421	725	371	750	404	1265	2024	730	820	510	650	6	Y280M-2	90	425
	12	2536	1481	785	401	765	434	1295	2084	730	820	510	650	6	Y280M-2	90	450

DG46-30 技术数据

DG46-30 x n 性能曲线

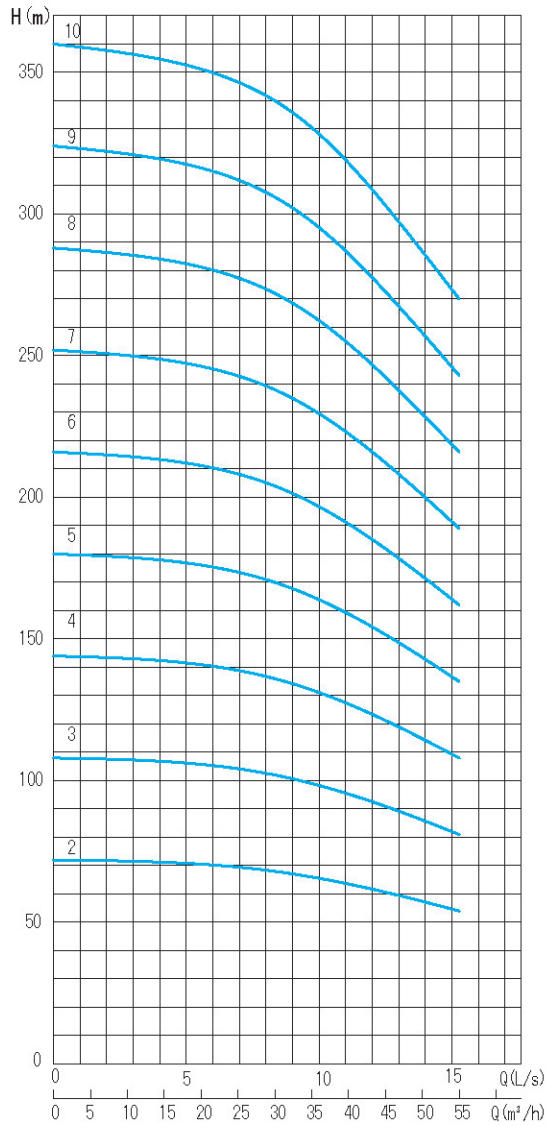

DG46-30 X n								
级数	流量		扬程	转速	轴功率	配用功率	效率	必需汽蚀余量
(n)	(m^3/h)	(L/s)	(m)	(r/min)	(kW)	(kW)	(%)	(m)
2	30	8.34	68	2950	8.68	15	64	2.4
	46	12.78	60		10.73		70	3.0
	55	15.28	54		11.89		68	4.6
3	30	8.34	102	2950	13.02	22	64	2.4
	46	12.78	90		16.10		70	3.0
	55	15.28	81		17.83		68	4.6
4	30	8.34	136	2950	17.35	30	64	2.4
	46	12.78	120		21.47		70	3.0
	55	15.28	108		23.78		68	4.6
5	30	8.34	170	2950	21.69	37	64	2.4
	46	12.78	150		26.83		70	3.0
	55	15.28	135		29.72		68	4.6
6	30	8.34	204	2950	26.03	37	64	2.4
	46	12.78	180		32.20		70	3.0
	55	15.28	162		35.67		68	4.6
7	30	8.34	238	2950	30.37	45	64	2.4
	46	12.78	210		37.57		70	3.0
	55	15.28	189		41.61		68	4.6
8	30	8.34	272	2950	34.71	55	64	2.4
	46	12.78	240		42.93		70	3.0
	55	15.28	216		47.56		68	4.6
9	30	8.34	306	2950	39.05	55	64	2.4
	46	12.78	270		48.30		70	3.0
	55	15.28	243		53.50		68	4.6
10	30	8.34	340	2950	43.39	75	64	2.4
	46	12.78	300		53.67		70	3.0
	55	15.28	270		59.45		68	4.6

单级性能曲线

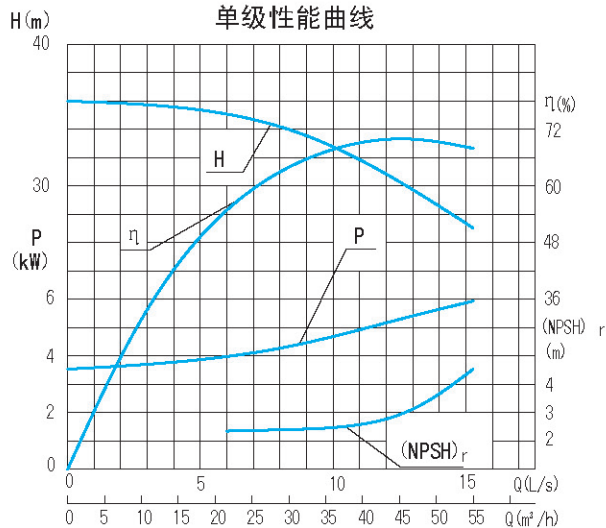

DG46-30 安装尺寸

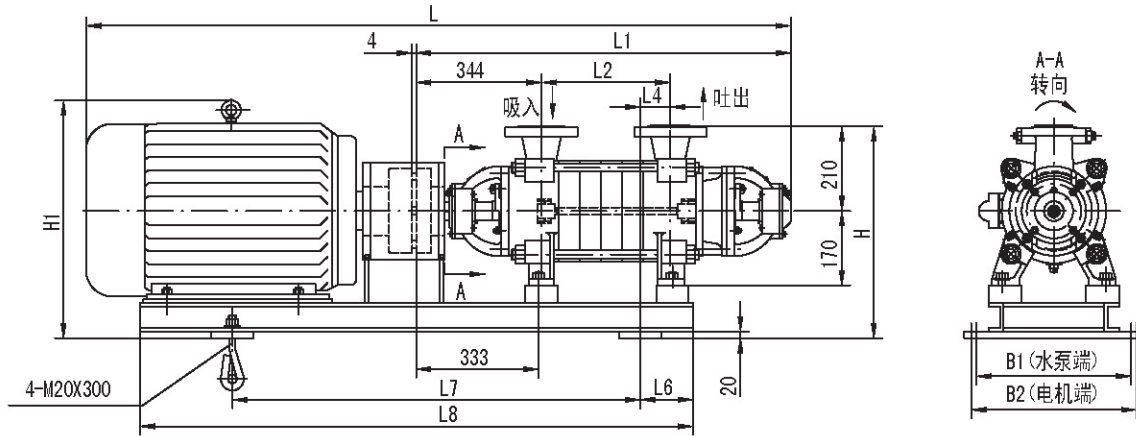

吸入配对法兰(0.6MPa)

DN80-PN6 RF GB/T9115.1-2000

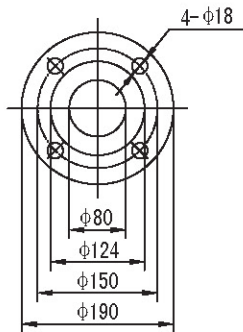

吐出配对法兰(4.0MPa)

DN65-PN40 F GB/T9115.2-2000

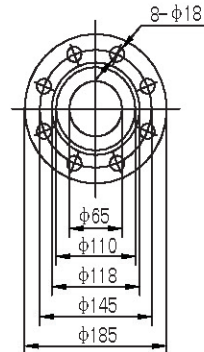

泵型号	泵级数	尺寸 mm										电动机		泵重kg	
		L	L1	L2	L4	L6	L7	L8	H	H1	B1	B2	型号		kW
DG46-30	2	1412	808	165	70	116	770	1032	470	485	440	440	Y160M ₂ -2	15	160
	3	1547	873	230	110	156	825	1147	488	528	440	440	Y180M-2	22	175
	4	1717	938	295	145	191	900	1293	508	573	440	440	Y200L ₁ -2	30	190
	5	1782	1003	360	175	221	931	1358	545	610	450	450	Y200L ₂ -2	37	205
	6	1847	1068	425	240	286	931	1423	545	610	450	450	Y200L ₂ -2	37	220
	7	1952	1133	490	228	274	966	1515	570	665	450	450	Y225M-2	45	235
	8	2132	1198	555	273	322	1070	1677	600	715	470	560	Y250M-2	55	250
	9	2197	1263	620	338	387	1070	1742	600	715	470	562	Y250M-2	55	265
	10	2332	1328	685	324	373	1200	1880	630	780	530	615	Y280S-2	75	280

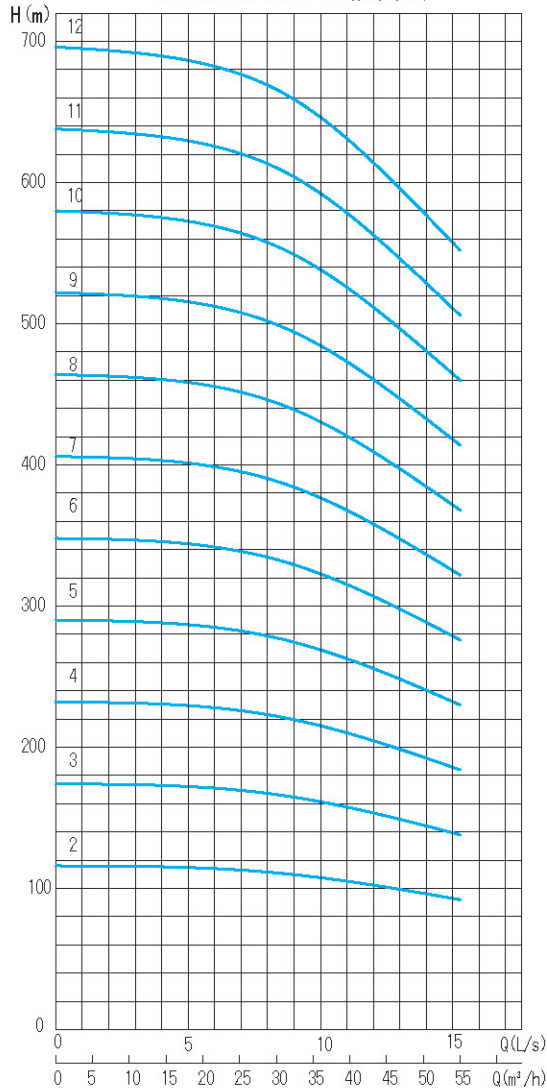
DG46-50 技术数据
DG46-50 x n 性能曲线

DG46-50×n								
级数	流量		扬程	转速	轴功率	配用功率	效率	必需汽蚀余量
(n)	(m^3/h)	(L/s)	(m)	(r/min)	(kW)	(kW)	(%)	(m)
2	30	8.34	111	2950	16.79	30	54	2.5
	46	12.78	100		19.88		63	2.8
	55	15.28	92		21.52		64	3.2
3	30	8.34	166.5	2950	25.18	37	54	2.5
	46	12.78	150		29.81		63	2.8
	55	15.28	138		32.28		64	3.2
4	30	8.34	222	2950	33.57	45	54	2.5
	46	12.78	200		39.75		63	2.8
	55	15.28	184		43.05		64	3.2
5	30	8.34	277.5	2950	41.97	55	54	2.5
	46	12.78	250		49.69		63	2.8
	55	15.28	230		53.81		64	3.2
6	30	8.34	333	2950	50.36	75	54	2.5
	46	12.78	300		59.63		63	2.8
	55	15.28	276		64.57		64	3.2
7	30	8.34	388.5	2950	58.75	90	54	2.5
	46	12.78	350		69.57		63	2.8
	55	15.28	322		75.33		64	3.2
8	30	8.34	444	2950	67.15	90	54	2.5
	46	12.78	400		79.51		63	2.8
	55	15.28	368		86.09		64	3.2
9	30	8.34	499.5	2950	75.54	110	54	2.5
	46	12.78	450		89.44		63	2.8
	55	15.28	414		96.85		64	3.2
10	30	8.34	555	2950	83.94	132	54	2.5
	46	12.78	500		99.38		63	2.8
	55	15.28	460		107.61		64	3.2
11	30	8.34	610.5	2950	92.33	132	54	2.5
	46	12.78	550		109.32		63	2.8
	55	15.28	506		118.37		64	3.2
12	30	8.34	666	2950	100.72	160	54	2.5
	46	12.78	600		119.26		63	2.8
	55	15.28	552		129.14		64	3.2

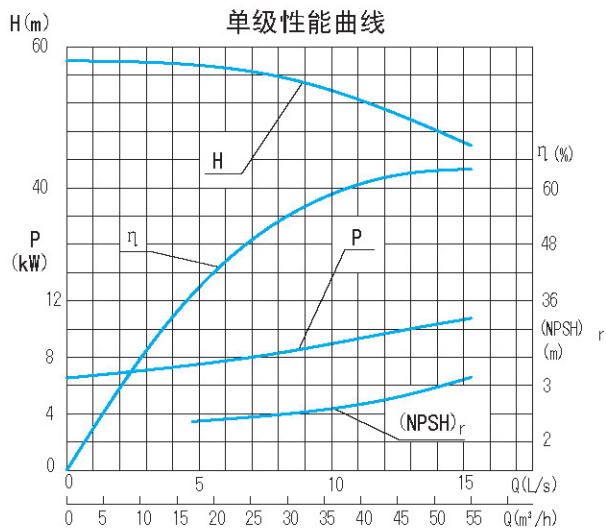
单级性能曲线

DG46-50 安装尺寸

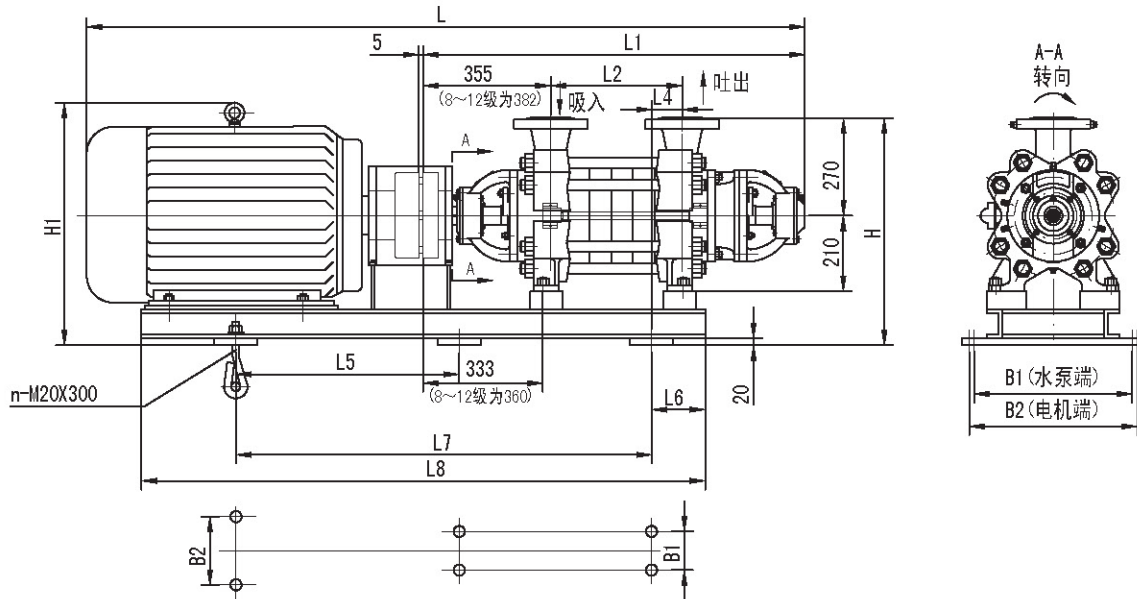

吸入、吐出配对法兰 (6.3MPa)

DN80-PN63 F GB/T9115.2-2000

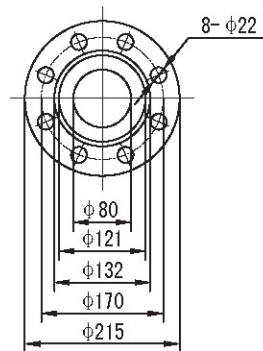

泵型号	泵级数	尺寸 mm											电动机		泵重kg		
		L	L1	L2	L4	L5	L6	L7	L8	H	H1	B1	B2	n		型号	kW
DG46-50	2	1661	881	185	102		135	845	1180	605	610	500	500	4	Y200L1-2	30	237
	3	1721	941	245	132		165	875	1240	605	610	500	500	4	Y200L2-2	37	256
	4	1821	1001	305	157		190	922	1330	635	670	530	530	4	Y225M-2	45	275
	5	1996	1061	365	194		227	970	1482	660	715	510	600	4	Y250M-2	55	294
	6	2126	1121	425	224	515	257	1030	1610	690	780	510	620	6	Y280S-2	75	313
	7	2236	1181	485	254	530	287	1060	1720	730	820	530	660	6	Y280M-2	90	335
	8	2394	1344	590	327	545	360	1120	1852	730	820	530	660	6	Y280M-2	90	390
	9	2649	1409	655	372	580	405	1170	1976	770	1050	530	720	6	Y315S-2	110	420
	10	2784	1474	720	407	620	440	1240	2082	770	1050	530	720	6	Y315M-2	132	450
	11	2849	1539	785	442	620	475	1270	2147	770	1050	530	720	6	Y315M-2	132	480
	12	2914	1604	850	469	635	510	1300	2272	785	1050	530	720	6	Y315L-2	160	510

DG48-50 技术数据

DG48-50 x n 性能曲线

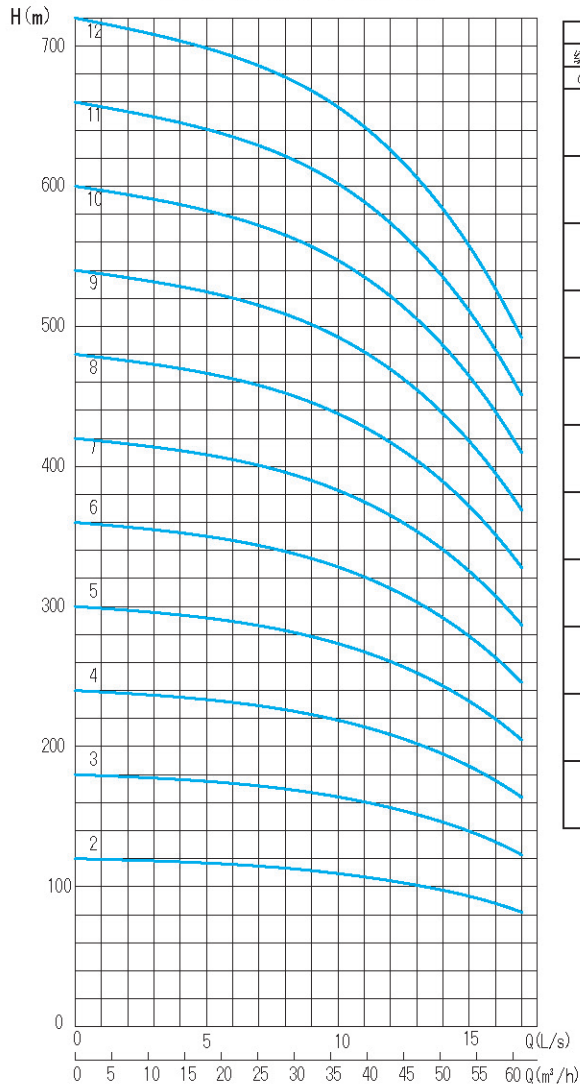

DG48-50×n								
级数	流量		扬程	转速	轴功率	配用功率	效率	必需汽蚀余量
(n)	(m ³ /h)	(L/s)	(m)	(r/min)	(kW)	(kW)	(%)	(m)
2	35	9.7	110	2950	18.72	30	56	2.5
	48	13.3	100		19.50		67	2.8
	60	16.7	84		20.18		68	3.2
3	35	9.7	165	2950	28.07	37	56	2.5
	48	13.3	150		29.25		67	2.8
	60	16.7	126		30.26		68	3.2
4	35	9.7	220	2950	37.43	45	56	2.5
	48	13.3	200		39.00		67	2.8
	60	16.7	168		40.35		68	3.2
5	35	9.7	275	2950	46.79	55	56	2.5
	48	13.3	250		48.76		67	2.8
	60	16.7	210		50.44		68	3.2
6	35	9.7	330	2950	56.15	75	56	2.5
	48	13.3	300		58.51		67	2.8
	60	16.7	252		60.53		68	3.2
7	35	9.7	385	2950	65.50	90	56	2.5
	48	13.3	350		68.26		67	2.8
	60	16.7	294		70.62		68	3.2
8	35	9.7	440	2950	74.86	90	56	2.5
	48	13.3	400		78.01		67	2.8
	60	16.7	336		80.71		68	3.2
9	35	9.7	495	2950	84.22	110	56	2.5
	48	13.3	450		87.76		67	2.8
	60	16.7	378		90.79		68	3.2
10	35	9.7	550	2950	93.58	132	56	2.5
	48	13.3	500		97.51		67	2.8
	60	16.7	420		100.88		68	3.2
11	35	9.7	605	2950	102.93	132	56	2.5
	48	13.3	550		107.26		67	2.8
	60	16.7	462		110.97		68	3.2
12	35	9.7	660	2950	112.29	160	56	2.5
	48	13.3	600		117.01		67	2.8
	60	16.7	504		121.06		68	3.2

单级性能曲线

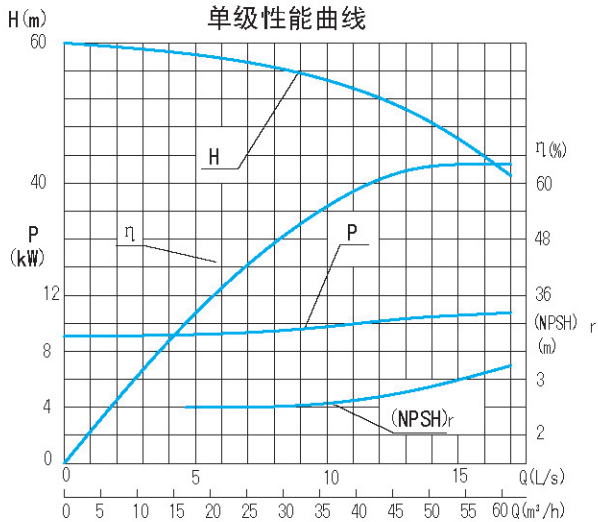

DG48-50 安装尺寸

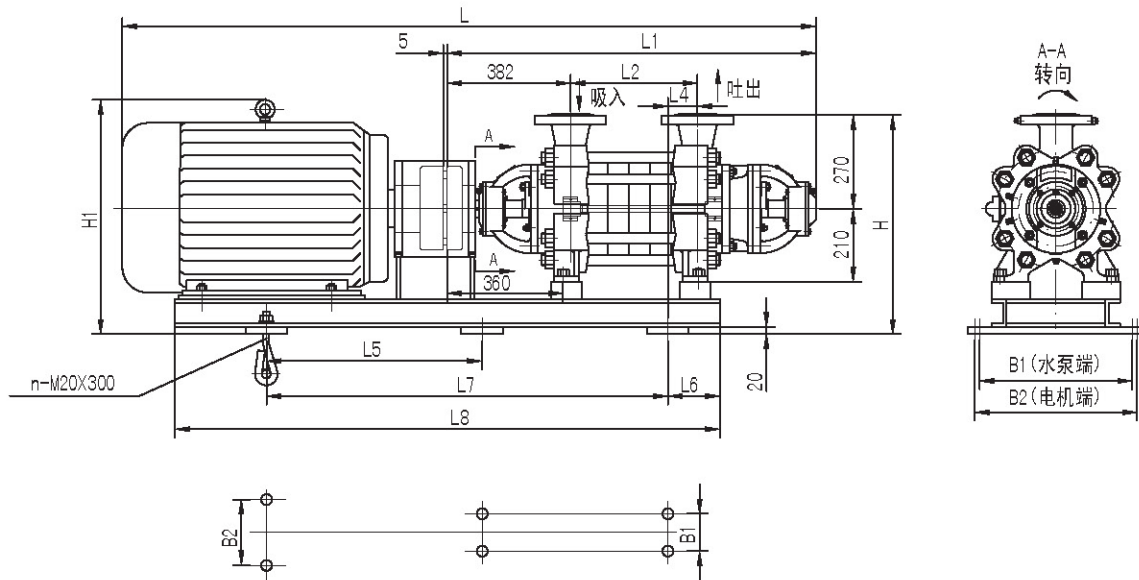

吸入、吐出配对法兰(6.3MPa)

DN80-PN63 F GB/T9115.2-2000

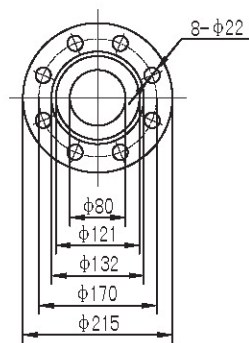

泵型号	泵级数	尺寸 mm											电动机		泵重kg		
		L	L1	L2	L4	L5	L6	L7	L8	H	H1	B1	B2	n		型号	kW
DG48-50	2	1729	954	200	117		150	872	1222	605	610	500	500	4	Y200L ₁ -2	30	267
	3	1794	1019	265	152		185	902	1287	605	610	500	500	4	Y200L ₂ -2	37	286
	4	1899	1084	330	182		215	949	1382	635	670	530	530	4	Y225M-2	45	305
	5	2079	1149	395	222		255	1000	1540	660	715	510	600	4	Y250M-2	55	324
	6	2214	1214	460	257	515	290	1060	1672	690	780	510	620	6	Y280S-2	75	343
	7	2329	1279	525	292	530	325	1090	1787	730	820	530	660	6	Y280M-2	90	365
	8	2394	1344	590	327	545	360	1120	1852	730	820	530	660	6	Y280M-2	90	390
	9	2649	1409	655	372	580	405	1170	1976	770	1050	530	720	6	Y315S-2	110	420
	10	2784	1474	720	407	620	440	1240	2082	770	1050	530	720	6	Y315M-2	132	450
	11	2849	1539	785	442	620	475	1270	2147	770	1050	530	720	6	Y315M-2	132	480
	12	2914	1604	850	469	635	510	1300	2272	785	1050	530	720	6	Y315L-2	160	510

DG85-45 技术数据

DG85-45 x n 性能曲线

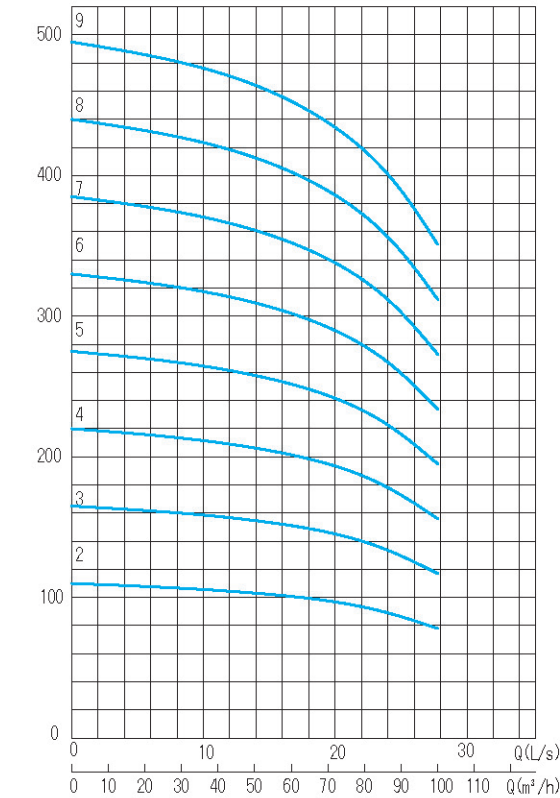

DG85-45 × n										
级数	流量		扬程	转速	轴功率	配用功率	效率	必需汽蚀余量		
(n)	(m ³ /h)	(L/s)	(m)	(r/min)	(kW)	(kW)	(%)	(m)		
2	55	15.28	102	2950	24.2	37	63	3.2		
	85	23.61	90		28.9				72	4.2
	100	27.78	78		30.3				70	5.2
3	55	15.28	153	2950	36.4	55	63	3.2		
	85	23.61	135		43.4				72	4.2
	100	27.78	117		45.5				70	5.2
4	55	15.28	204	2950	48.5	75	63	3.2		
	85	23.61	180		57.8				72	4.2
	100	27.78	156		60.7				70	5.2
5	55	15.28	255	2950	60.6	90	63	3.2		
	85	23.61	225		72.3				72	4.2
	100	27.78	195		75.8				70	5.2
6	55	15.28	306	2950	72.7	110	63	3.2		
	85	23.61	270		86.8				72	4.2
	100	27.78	234		91.0				70	5.2
7	55	15.28	357	2950	84.8	132	63	3.2		
	85	23.61	315		101.2				72	4.2
	100	27.78	273		106.2				70	5.2
8	55	15.28	408	2950	97.0	132	63	3.2		
	85	23.61	360		115.7				72	4.2
	100	27.78	312		121.3				70	5.2
9	55	15.28	459	2950	109.1	160	63	3.2		
	85	23.61	405		130.2				72	4.2
	100	27.78	351		136.5				70	5.2

单级性能曲线

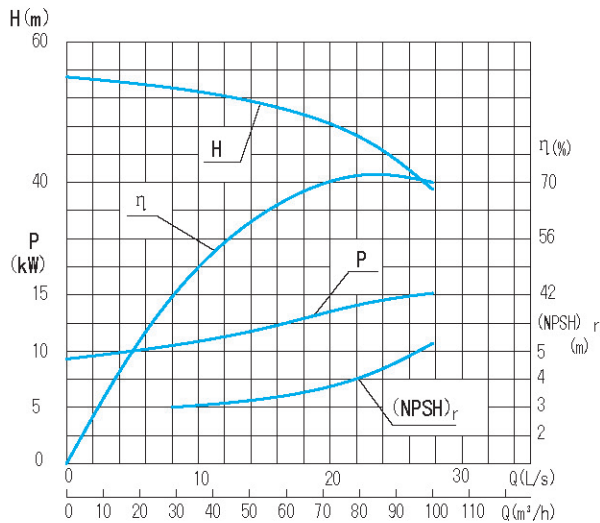

DG85-45 安装尺寸

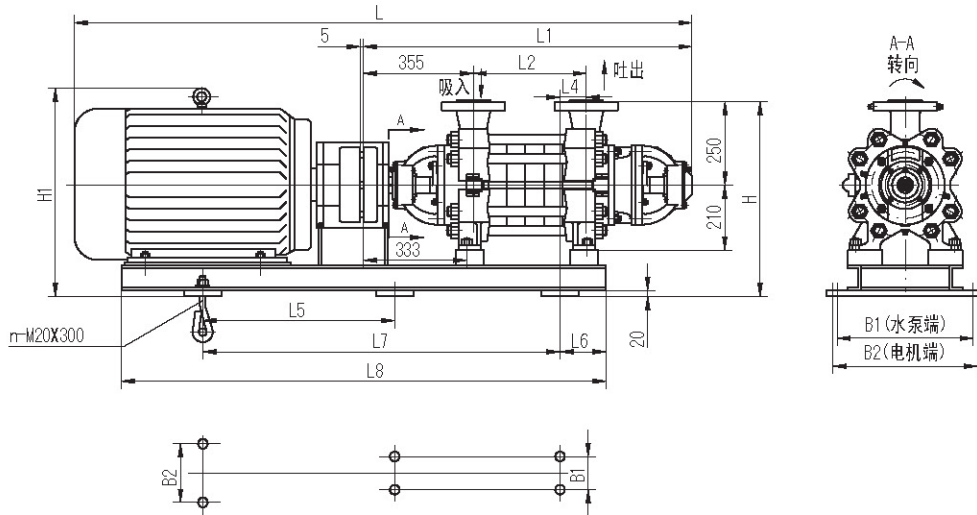

吸入配对法兰(0.6MPa)

DN100-PM6 RF GB/T9115.1-2000

吐出配对法兰(4.0MPa)

DN100-PM40 F GB/T9115.2-2000

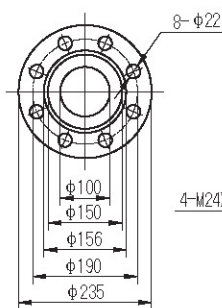
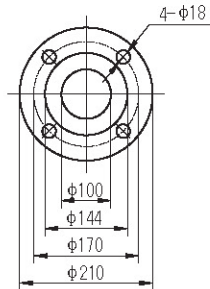

DG85-45X9 带单泵座安装尺寸

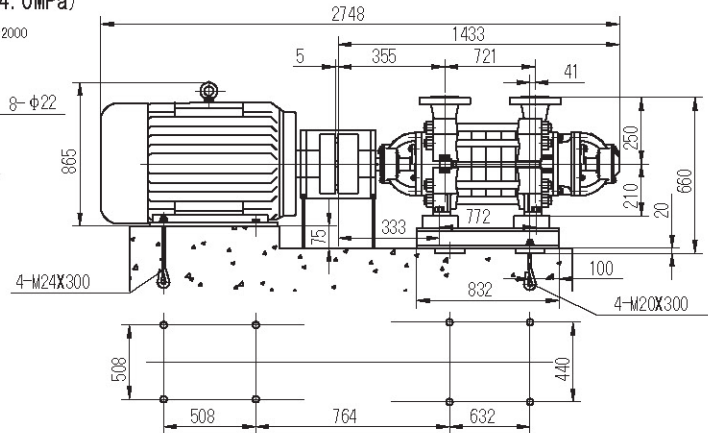

泵型号	泵级数	尺寸 mm										电动机			泵重 kg		
		L	L1	L2	L4	L5	L6	L7	L8	H	H1	B1	B2	n		型号	kW
DG85-45	2	1695	915	203	98		157	860	1215	600	625	530	530	4	Y200L ₂ -2	37	230
	3	1924	989	277	134		190	985	1412	645	720	510	600	4	Y250M-2	55	248
	4	2068	1063	351	168	600	230	1055	1565	675	785	510	630	6	Y280S-2	75	265
	5	2192	1137	425	208	600	270	1110	1688	715	825	560	670	6	Y280M-2	90	285
	6	2456	1211	499	243	720	310	1175	1798	755	1055	560	710	6	Y315S-2	110	303
	7	2600	1285	573	283	745	350	1235	1923	755	1055	560	710	6	Y315M-2	132	320
	8	2674	1359	647	322	745	389	1270	1997	755	1055	560	710	6	Y315M-2	132	340
	9	2748	1433	721	361	770	428	1330	2123	755	1055	560	710	6	Y315L ₁ -2	160	360

DG85-67 技术数据

DG85-67 x n 性能曲线

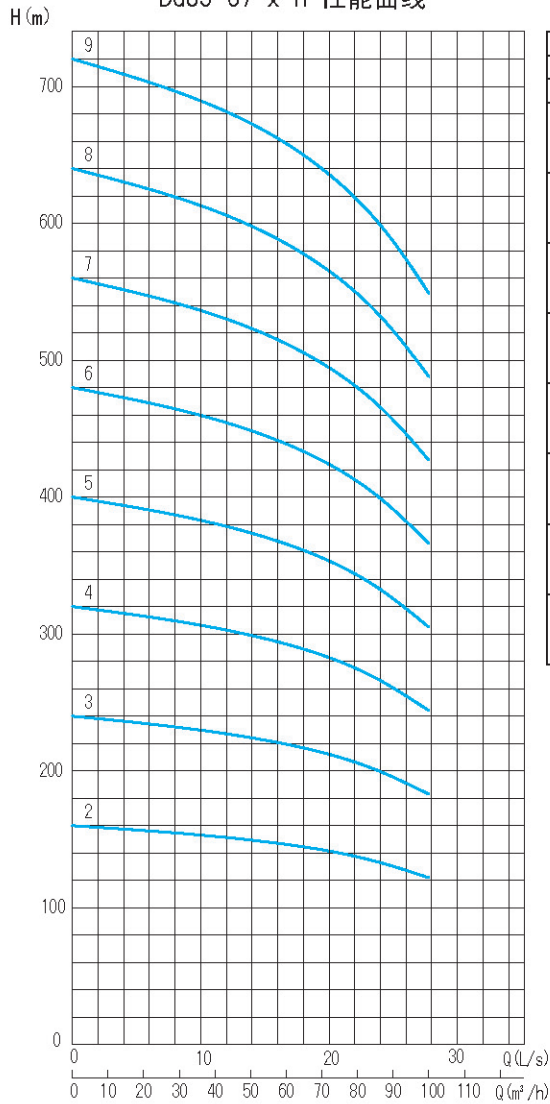

DG85-67 X n								
级数	流量		扬程	转速	轴功率	配用功率	效率	必需汽蚀余量
(n)	(m³/h)	(L/s)	(m)	(r/min)	(kW)	(kW)	(%)	(m)
2	55	15.28	148	2950	41.0	75	54	3.3
	85	23.61	134		47.7		65	4.0
	100	27.78	122		51.1		65	4.4
3	55	15.28	222	2950	61.6	90	54	3.3
	85	23.61	201		71.6		65	4.0
	100	27.78	183		76.6		65	4.4
4	55	15.28	296	2950	82.1	110	54	3.3
	85	23.61	268		95.4		65	4.0
	100	27.78	244		102.2		65	4.4
5	55	15.28	370	2950	102.6	132	54	3.3
	85	23.61	335		119.3		65	4.0
	100	27.78	305		127.7		65	4.4
6	55	15.28	444	2950	123.1	160	54	3.3
	85	23.61	402		143.1		65	4.0
	100	27.78	366		153.3		65	4.4
7	55	15.28	518	2950	143.6	200	54	3.3
	85	23.61	469		167.0		65	4.0
	100	27.78	427		178.8		65	4.4
8	55	15.28	592	2950	164.1	220	54	3.3
	85	23.61	536		190.8		65	4.0
	100	27.78	488		204.4		65	4.4
9	55	15.28	666	2950	184.7	250	54	3.3
	85	23.61	603		214.7		65	4.0
	100	27.78	549		229.9		65	4.4

单级性能曲线

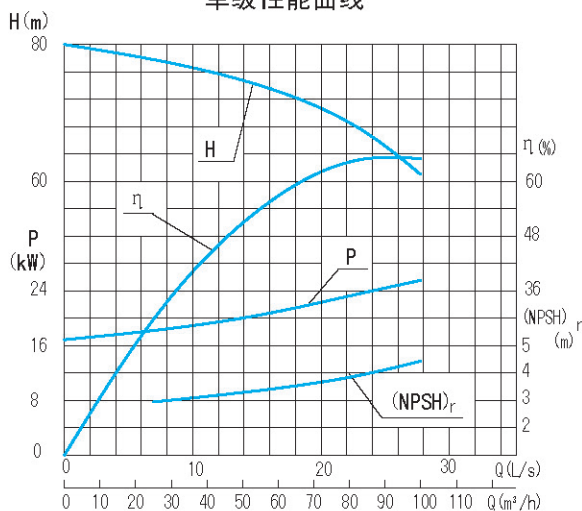

DG85-67 安装尺寸(滚动轴承结构)

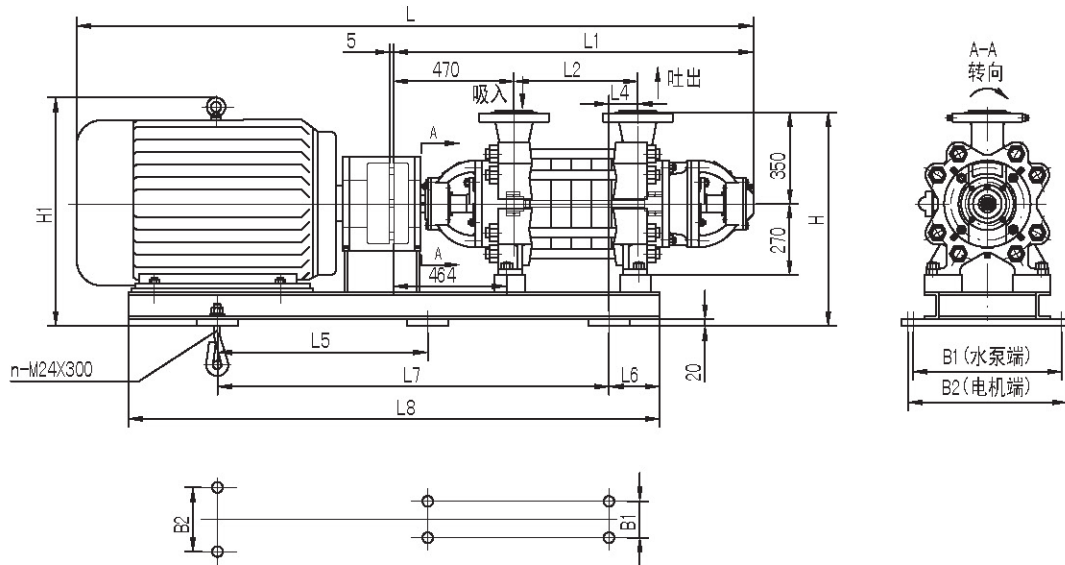

DG85-67X6~9 带单泵座安装尺寸(滚动轴承结构)

吸入、吐出配对法兰(6.3MPa)

DN100-PN63 F GB/T9115.2-2000

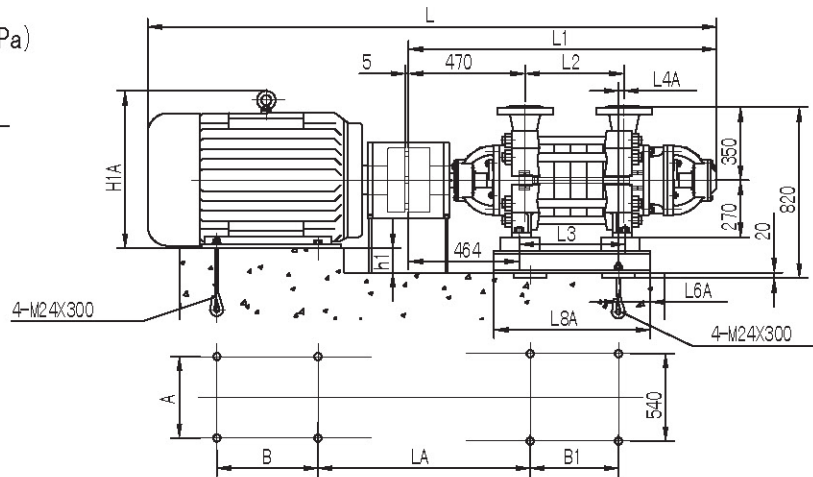
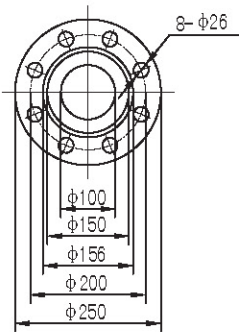

泵型号	泵级数	公共底座安装尺寸 mm											n	电动机		泵重kg	
		L	L1	L2	L4	L5	L6	L7	L8	H	H1	B1		B2	型号		kW
DG85-67	2	2185	1180	283	150		204	1135	1620	805	815	540	650	4	Y280S-2	75	540
	3	2323	1268	371	196		250	1202	1758	805	815	540	650	4	Y280M-2	90	590
	4	2603	1356	459	236		290	1259	1881	845	1045	540	660	4	Y315S-2	110	640
	5	2759	1444	547	278		332	1330	2019	845	1045	540	660	4	Y315M-2	132	690
	6	2847	1532	635	326	800	380	1395	2157	865	1065	540	680	6	Y315L ₁ -2	160	740

泵型号	泵级数	带单泵座安装尺寸 mm											LA	电动机		泵重kg	
		L	L1	L2	L3	L4A	L6A	L8A	H1A	h1	A	B		B1	型号		kW
DG85-67	6	2847	1532	635	635	46	100	755	865	135	508	508	555	865	Y315L ₁ -2	160	740
	7	2935	1620	723	723	46	100	843	865	135	508	508	643	865	Y315L ₂ -2	200	790
	8	3253	1708	811	811	46	100	931	1035	95	610	560	731	903	Y355M ₁ -2	220	840
	9	3341	1796	899	899	46	100	1019	1035	95	610	560	819	903	Y355M ₂ -2	250	890

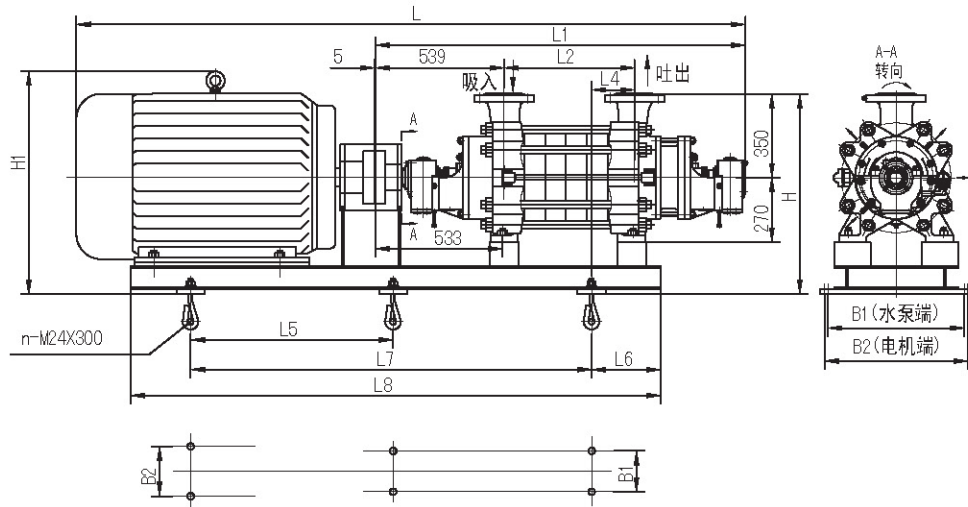
DG85-67 安装尺寸(滑动轴承结构)

DG85-67X6~9 带单泵座安装尺寸(滑动轴承结构)
吸入、吐出配对法兰(6.3MPa)

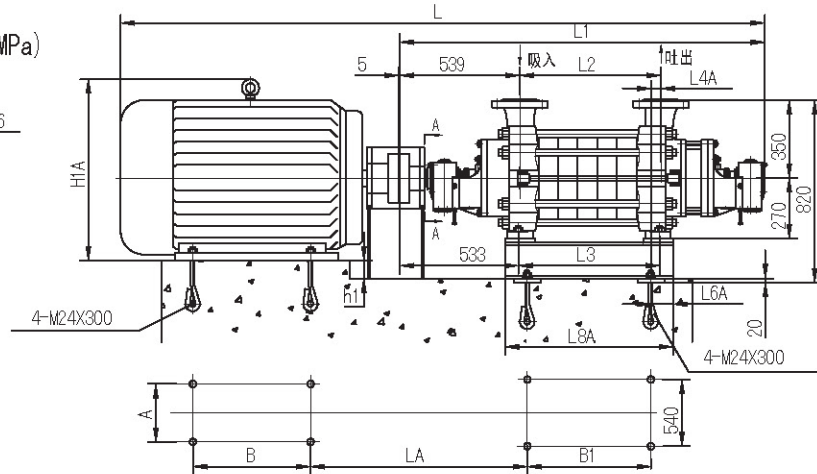
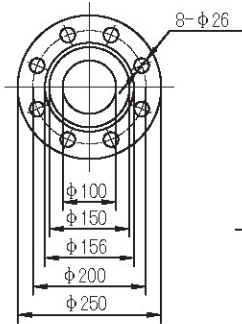
DN100-PN63 F GB/T19115.2-2000



泵型号	泵级数	公共底座安装尺寸 mm											n	电动机		泵重kg	
		L	L1	L2	L4	L5	L6	L7	L8	H	H1	B1		B2	型号		kW
DG85-67	2	2292	1287	283	150		204	1204	1689	805	815	540	650	4	Y280S-2	75	560
	3	2430	1375	371	196		250	1271	1827	805	815	540	650	4	Y280M-2	90	610
	4	2710	1463	459	236		290	1328	1950	845	1045	540	660	4	Y315S-2	110	660
	5	2866	1551	547	278		332	1399	2088	845	1045	540	660	4	Y315M-2	132	710
	6	2954	1639	635	326	800	380	1464	2226	865	1065	540	680	6	Y315L ₁ -2	160	760

泵型号	泵级数	带单泵座安装尺寸 mm											n	电动机		泵重kg	
		L	L1	L2	L3	L4A	L6A	L8A	H1A	h1	A	B		B1	LA		型号
DG85-67	6	2954	1639	635	635	46	100	755	865	135	508	508	555	934	Y315L ₁ -2	160	760
	7	3042	1727	723	723	46	100	843	865	135	508	508	643	934	Y315L ₂ -2	200	810
	8	3360	1815	811	811	46	100	931	1035	95	610	560	731	972	Y355M ₁ -2	220	860
	9	3448	1903	899	899	46	100	1019	1035	95	610	560	819	972	Y355M ₂ -2	250	910

DG100-50 技术数据

DG100-50 x n 性能曲线

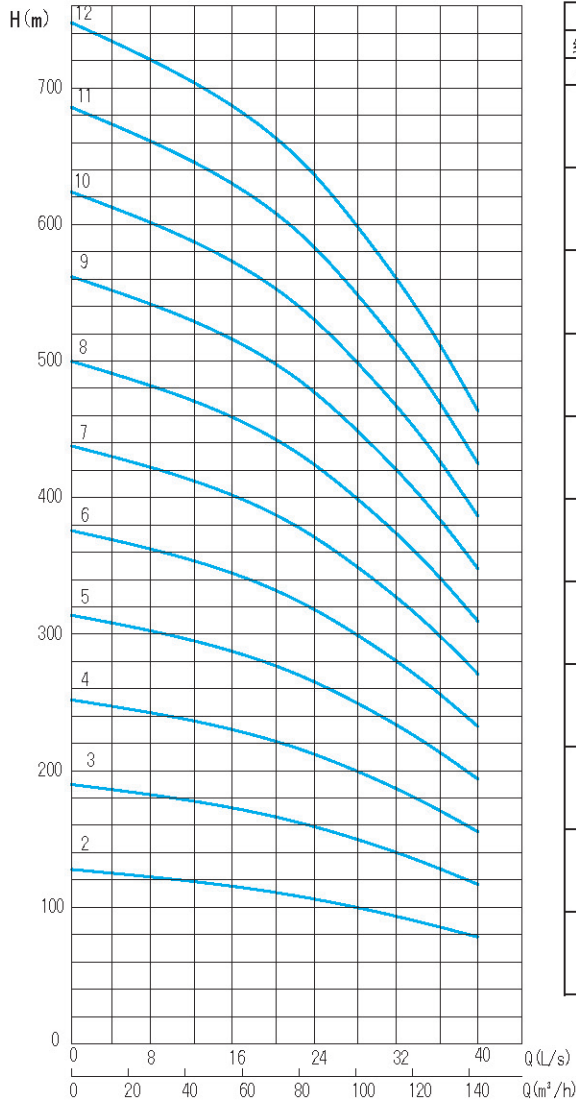

DG100-50 X n								
级数	流量		扬程	转速	轴功率	配用功率	效率	必需汽蚀余量
(n)	(m³/h)	(L/s)	(m)	(r/min)	(kW)	(kW)	(%)	(m)
2	80	22.2	108	2950	34.59	55	68	3.8
	100	27.8	100		37.81		72	4.1
	125	34.7	88		41.59		72	4.8
3	80	22.2	162	2950	51.88	75	68	3.8
	100	27.8	150		56.71		72	4.1
	125	34.7	132		62.38		72	4.8
4	80	22.2	216	2950	69.18	90	68	3.8
	100	27.8	200		75.62		72	4.1
	125	34.7	176		83.18		72	4.8
5	80	22.2	270	2950	86.47	132	68	3.8
	100	27.8	250		94.52		72	4.1
	125	34.7	220		103.97		72	4.8
6	80	22.2	324	2950	103.76	132	68	3.8
	100	27.8	300		113.43		72	4.1
	125	34.7	264		124.77		72	4.8
7	80	22.2	378	2950	121.06	160	68	3.8
	100	27.8	350		132.33		72	4.1
	125	34.7	308		145.56		72	4.8
8	80	22.2	432	2950	138.35	200	68	3.8
	100	27.8	400		151.23		72	4.1
	125	34.7	352		166.36		72	4.8
9	80	22.2	486	2950	155.65	200	68	3.8
	100	27.8	450		170.14		72	4.1
	125	34.7	396		187.15		72	4.8
10	80	22.2	540	2950	172.94	250	68	3.8
	100	27.8	500		189.04		72	4.1
	125	34.7	440		207.95		72	4.8
11	80	22.2	694	2950	222.26	250	68	3.8
	100	27.8	550		207.95		72	4.1
	125	34.7	484		228.74		72	4.8
12	80	22.2	648	2950	207.53	280	68	3.8
	100	27.8	600		226.85		72	4.1
	125	34.7	528		249.54		72	4.8

单级性能曲线

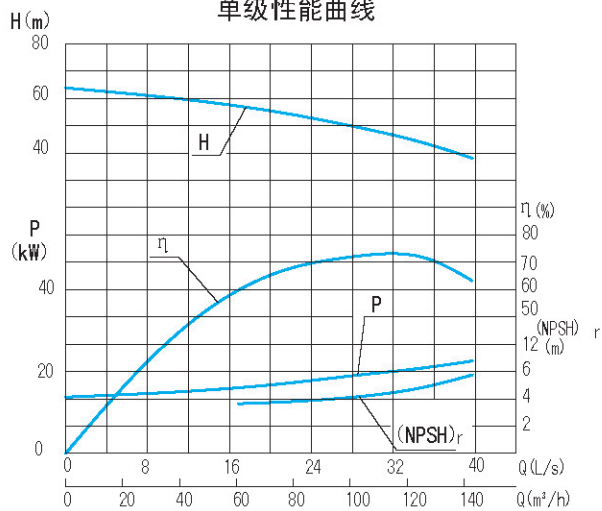

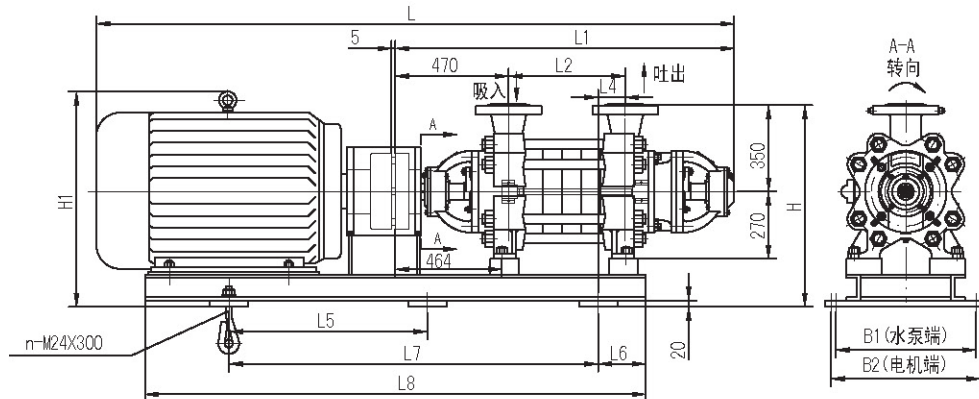
DG100-50 安装尺寸

吸入配对法兰 (6.3MPa)

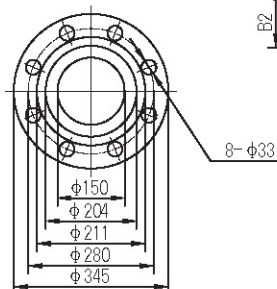
DN150-PN63 F GB/T9115.2-2000

吐出配对法兰 (6.3MPa)

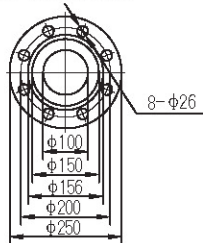
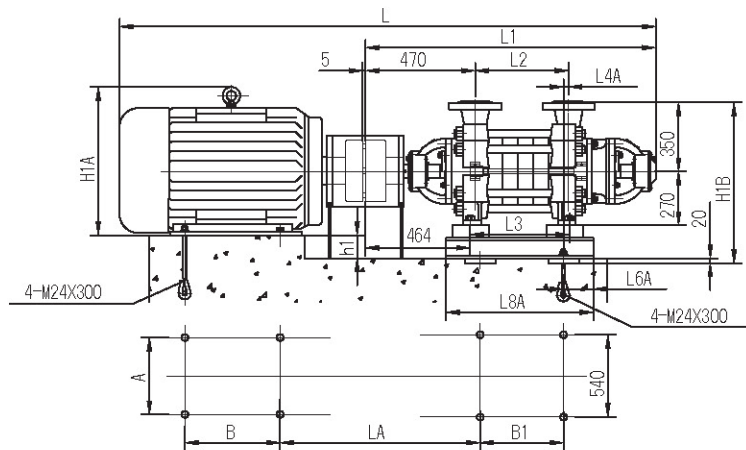
DN100-PN63 F GB/T9115.2-2000

DG100-50X7~12 带单泵座安装尺寸

泵型号	泵级数	公用底座安装尺寸 mm													电动机		泵重 kg
		L	L1	L2	L4	L5	L6	L7	L8	H	H1	B1	B2	n	型号	kW	
DG 100-50	2	2116	1181	283	150	-	204	1047	1536	760	735	540	600	4	Y250M-2	55	550
	3	2274	1269	371	187	-	241	1154	1707	805	815	540	650	4	Y280S-2	75	600
	4	2412	1357	459	206	801	260	1280	1846	805	815	540	650	6	Y280M-2	90	650
	5	2760	1445	547	269	622	323	1344	1969	845	1045	540	660	6	Y315M-2	132	700
	6	2848	1533	635	280	615	334	1417	2107	845	1045	540	660	6	Y315M-2	132	750
	7	2936	1621	723	327	800	381	1482	2245	865	1065	540	680	6	Y315L1-2	160	800

泵型号	泵级数	带单泵座安装尺寸 mm													电动机		泵重 kg	
		L	L1	L2	L3	L4A	L6A	L8A	H1A	H1B	h1	A	B	B1	LA	型号		kW
DG100-50	7	2936	1621	723	723	46	100	843	865	845	160	508	508	643	865	Y315L1-2	160	800
	8	3024	1709	811	811	46	100	931	865	845	160	508	508	731	865	Y315L2-2	200	850
	9	3112	1797	899	899	46	100	1019	865	845	160	508	508	819	865	Y315L2-2	200	900
	10	3430	1885	987	987	46	100	1107	1035	845	120	610	560	907	903	Y355M2-2	250	950
	11	3518	1973	1075	1075	46	100	1195	1035	845	120	610	560	995	903	Y355M2-2	250	1000
	12	3606	2061	1163	1163	46	100	1283	1035	845	120	610	630	1083	903	Y355L1-2	280	1050

DG155-67 技术数据

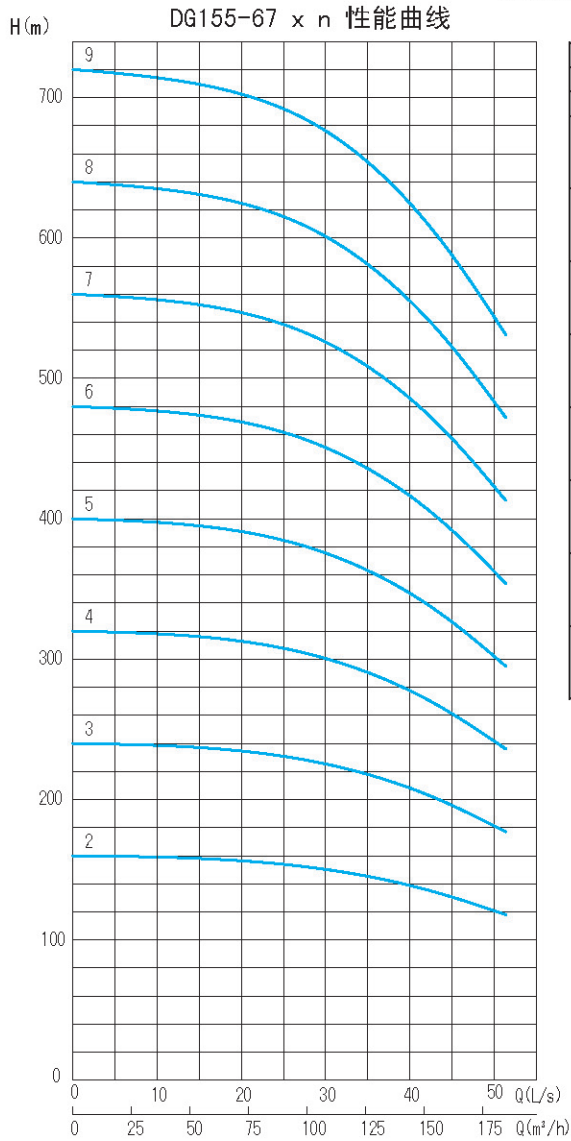

DG155-67×n								
级数	流量		扬程	转速	轴功率	配用功率	效率	必需汽蚀余量
(n)	(m³/h)	(L/s)	(m)	(r/min)	(kW)	(kW)	(%)	(m)
2	100	27.78	152	2950	64.7	90	64	3.2
	155	43.06	134		76.4		74	5.0
	185	51.39	118		82.5		72	6.6
3	100	27.78	228	2950	97.0	132	64	3.2
	155	43.06	201		114.6		74	5.0
	185	51.39	177		123.8		72	6.6
4	100	27.78	304	2950	129.3	185	64	3.2
	155	43.06	268		152.8		74	5.0
	185	51.39	236		165.1		72	6.6
5	100	27.78	380	2950	161.6	220	64	3.2
	155	43.06	335		191.0		74	5.0
	185	51.39	295		206.3		72	6.6
6	100	27.78	456	2950	194.0	280	64	3.2
	155	43.06	402		229.2		74	5.0
	185	51.39	354		247.6		72	6.6
7	100	27.78	532	2950	226.3	315	64	3.2
	155	43.06	469		267.4		74	5.0
	185	51.39	413		288.9		72	6.6
8	100	27.78	608	2950	258.6	355	64	3.2
	155	43.06	536		305.6		74	5.0
	185	51.39	472		330.1		72	6.6
9	100	27.78	684	2950	290.9	450	64	3.2
	155	43.06	603		343.8		74	5.0
	185	51.39	531		371.4		72	6.6

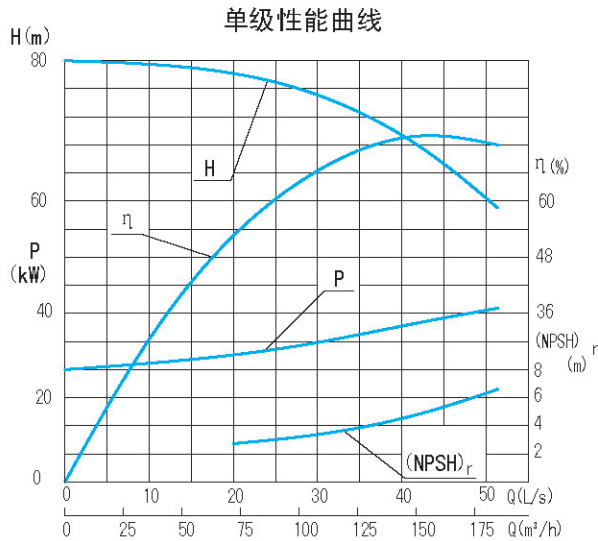

DG155-67 安装尺寸 (滚动轴承结构)

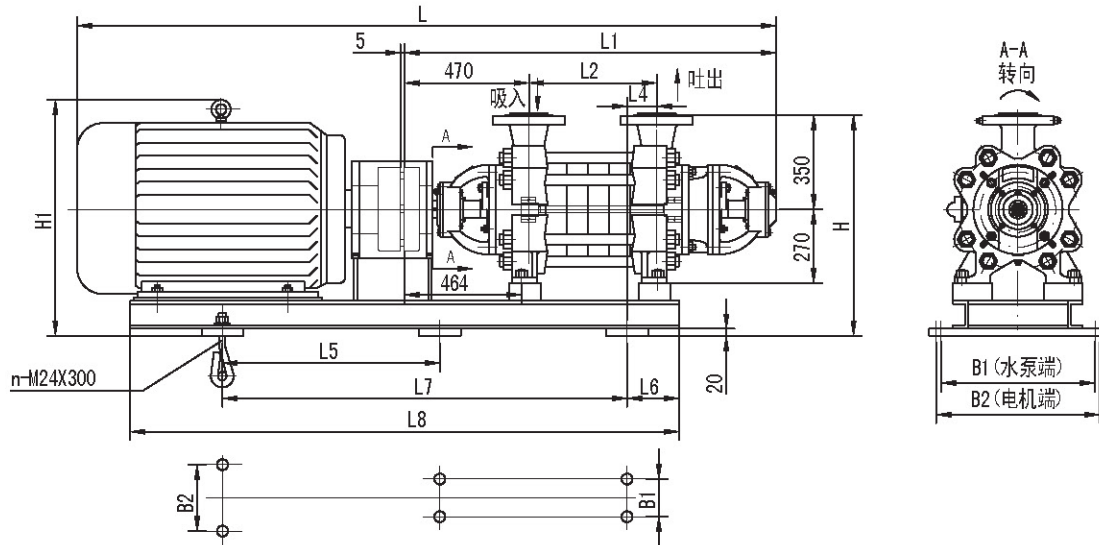

DG155-67X4~9 带泵座安装尺寸 (滚动轴承结构)

吸入、吐出配对法兰 (6.3MPa)

DN150-PN63 F GB/T9115.2-2000

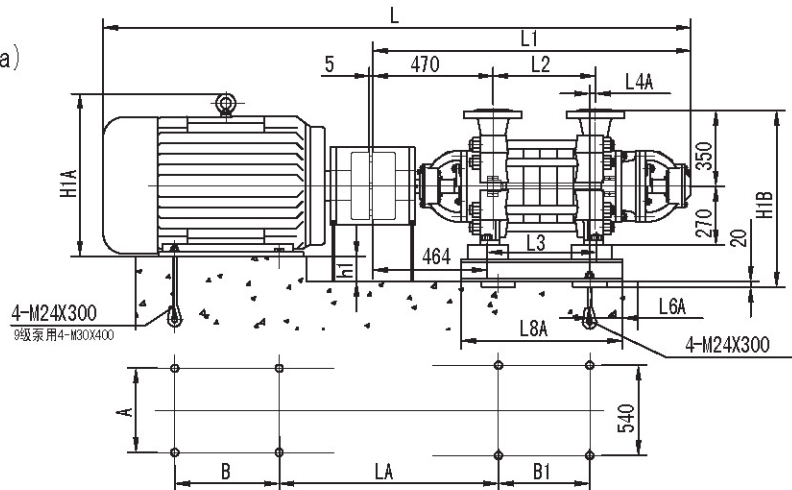
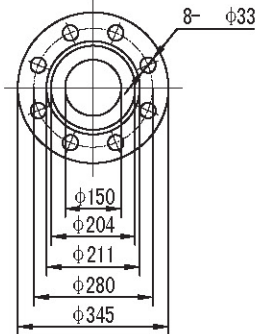

泵型号	泵级数	公共底座安装尺寸 mm											电动机		泵重kg		
		L	L1	L2	L4	L5	L6	L7	L8	H	H1	B1	B2	n		型号	kW
DG155-67	2	2235	1180	283	150		204	1160	1670	805	810	540	650	4	Y280M-2	90	550
	3	2583	1268	371	191		245	1241	1843	845	1045	540	660	4	Y315M-2	132	600

泵型号	泵级数	带单泵座安装尺寸 mm													电动机		泵重kg	
		L	L1	L2	L3	L4A	L6A	L8A	H1A	H1B	h1	A	B	B1	LA	型号		kW
DG155-67	4	2771	1356	459	459	46	100	579	1010	820	95	610	500	379	903	Y ₂ 355S ₁ -2	185	650
	5	2989	1444	547	547	46	100	667	1035	820	95	610	560	467	903	Y355M ₁ -2	220	700
	6	3077	1532	635	635	46	100	755	1035	845	120	610	630	555	903	Y355L ₁ -2	280	750
	7	3165	1620	723	723	46	100	843	1035	845	120	610	630	643	903	Y355L ₂ -2	315	800
	8	3253	1708	811	811	46	100	931	1600	845	120	630	900	731	994	Y3555-2-6KV	355	850
	9	3891	1796	899	899	46	100	1019	1870	845	75	710	1000	819	1054	Y4001-2-6KV	450	900

DG155-67 安装尺寸 (滑动轴承结构)

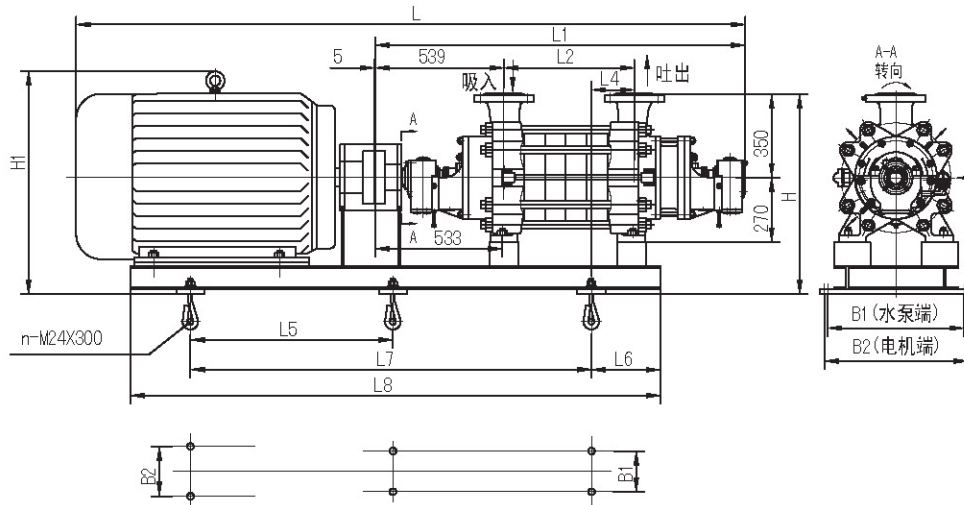

DG155-67X4~9 带泵座安装尺寸 (滑动轴承结构)

吸入、吐出配对法兰 (6.3MPa)

DN150-PN63 F GB/T9115.2-2000

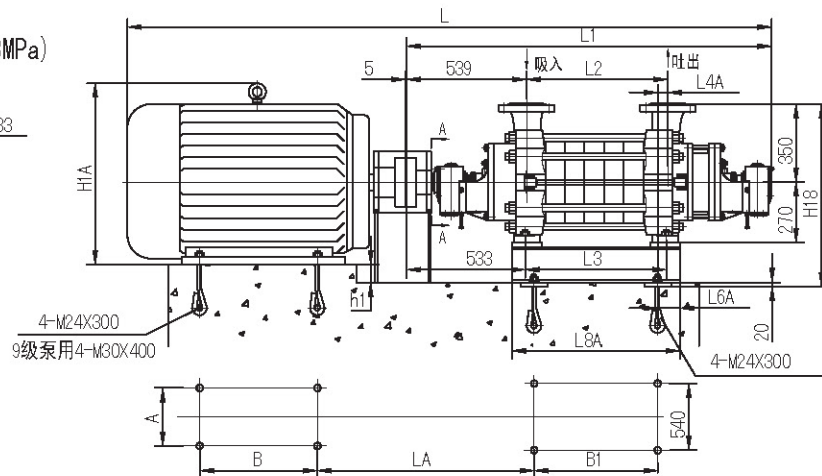
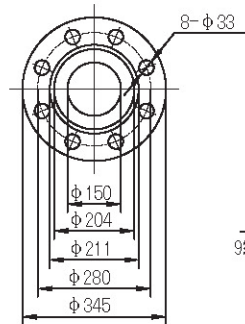

泵型号	泵级数	公共底座安装尺寸 mm											电动机		泵重kg		
		L	L1	L2	L4	L5	L6	L7	L8	H	H1	B1	B2	n		型号	kW
DG155-67	2	2342	1287	283	150		204	1229	1739	805	810	540	650	4	Y280M-2	90	570
	3	2690	1375	371	191		245	1310	1912	845	1045	540	660	4	Y315M-2	132	620

泵型号	泵级数	带泵座安装尺寸 mm											电动机		泵重kg			
		L	L1	L2	L3	L4A	L6A	L8A	H1A	H1B	h1	A	B	B1		LA	型号	kW
DG155-67	4	2878	1463	459	459	46	100	579	1010	820	95	610	500	379	972	Y ₂ 355S ₁ -2	185	670
	5	3096	1551	547	547	46	100	667	1035	820	95	610	560	467	972	Y355M ₁ -2	220	720
	6	3184	1639	635	635	46	100	755	1035	845	120	610	630	555	972	Y355L ₁ -2	280	770
	7	3272	1727	723	723	46	100	843	1035	845	120	610	630	643	972	Y355L ₂ -2	315	820
	8	3360	1815	811	811	46	100	931	1060	845	120	630	900	731	1063	Y3555-2-6KV	355	870
	9	3998	1903	899	899	46	100	1019	1180	845	75	710	1000	819	1123	Y4001-2-6KV	450	920

有凯泉的地方就有水！



地址：上海市汶水路857号 总机电话：021-56505666
网址：www.kaiquan.com.cn 咨询电话：021-56686666
服务热线：021-69591067 销售热线：021-56683117
免费服务电话：8008205566 传 真：021-56519932