

# 第六代KQL/KQW系列立式/卧式 单级单吸离心泵

Generation-6KQL/KQW Series Single Stage  
Vertical / horizontal Centrifugal Pump

有凯泉的地方就有水



- 结构紧凑、合理**  
泵与电机直接连接，外形美观，占地面积小
- 效率高**  
闭式铸铁叶轮，优秀的水力模型保证泵的高效和节能，大部分型号泵的配套功率下降一档
- 可靠性强**  
SKF 轴承配置合理，叶轮悬臂短，机泵轴完全同心，泵运行平稳、可靠，噪音低
- 寿命长**  
45钢镀铬转轴，永不生锈，强制环流冲洗进口品牌机械密封，免保养、无渗漏、3年免维护







# 凯泉与SKF战略合作

## SKF根植中国，凯泉走向世界！

### 斯凯孚 (SKF) 商标使用授权书

授权方：斯凯孚（中国）销售有限公司

兹授权：上海凯泉泵业（集团）有限公司及其下属分公司

允许在其生产的装配有SKF产品的工业泵系列产品（具体产品系列及型号详见协议附件）上使用“SKF Equipped”商标。详细条款请见双方签署的“商标使用协议”



授权时间：2017年11月1日  
授权地点：上海

斯凯孚（中国）销售有限公司  
二零一七年十一月一日

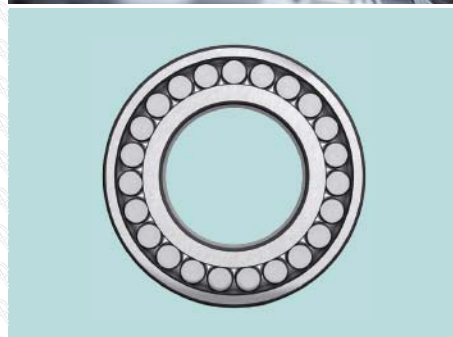

## 凯泉成为全球率先允许在设备上使用SKF Equipped商标的企业！

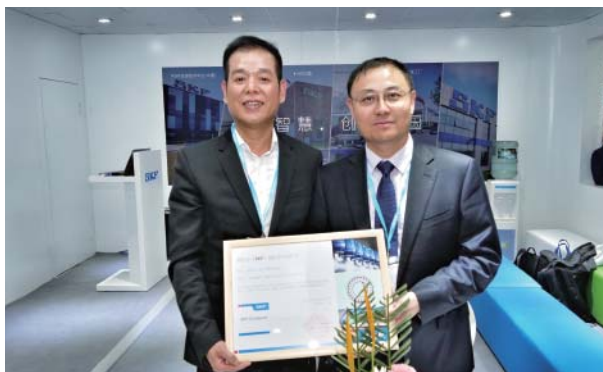

上海凯泉是集设计/生产/销售泵、给水设备及泵用控制设备于一体的大型综合性泵业集团，是中国泵行业的龙头企业。集团现有员工4500多人，其中工程技术人员750多名，主要由知名水泵专家教授、博士硕士、中高级工程师构成，形成了具有创新思维的梯队人才结构。在上海、浙江、河北、辽宁、安徽等省市拥有7家企业，5个工业园区。上海凯泉集团获得了“上海市科技百强企业”、“上海市名牌产品”、“中国质量信用AAA级”、“全国合同信用等级AAA级”、“质量、信誉、服务三优企业”、“中国最具竞争力的商品商标”等光荣称号，至今名列泵行业之首。

斯凯孚集团不断致力于减小摩擦,使机械设备的运行速度更快,使用寿命更长,更环保和更安全。秉承高效和可持续性的经营理念,斯凯孚集团是滚动轴承、密封件、机电一体化、服务和润滑系统领域全球知名的产品、解决方案和服务供应商。服务包括技术支持、维护服务、状态监测、资产效率优化、工程咨询和培训。

时至今日,斯凯孚在全球拥有130多座生产基地,销售公司遍布130多个国家,有超过17,000家经销商店,为世界各地客户提供符合全球质量标准的定制化解决方案和产品。

# 目 录

一、用途	01
二、使用说明	01
三、型号说明	01
四、材质	01
五、结构	02
六、电机	02
七、泵机组优点	02
八、供货范围	03
九、订货须知	03
十、型谱图	04
十一、KQL结构图	05
十二、KQW结构图	05
十三、性能曲线图、参数表、安装尺寸图	06
十四、附件及安装基础尺寸图标	44
十五、KQL泵的安装方式	45
十六、与原型号对照表	47



### 用途Applications

用于空调、采暖、卫生用水、水处理、冷却冷冻系统,液体循环和供水、增压及灌溉等领域中无腐蚀的冷水和热水输送。介质固体不溶物,其体积不超过单位体积0.1%, 粒度 < 0.2mm

Sending non-corrosive cold and warm water used in air-condition, heat circulation, freezing water system, water supply, press increased and irrigation. The volume should not exceed the unit volume by 0.1% and particale size should be less then 0.2mm.

泵送液体	使用温度	机械密封材质
水	地下水	<80° C AQ2EFF
	锅炉给水	<80° C AQ2EFF
		<120° C AQ2VFF
	冷凝水	<80° C Q2Q2EFF
	区域供暖用水	80~120° C AQ2VFF
	含油水	<80° C Q2Q2VFF
	软化水	<80° C Q2Q2EFF
冷却和切削润滑剂		Q2Q2VFF
冷却剂	醇类化合物 (液体)	<50° C 40% Q2Q2EFF
	30%盐水 (如氯化钠、氯化钙等溶液)	<5° C Q2Q2EFF

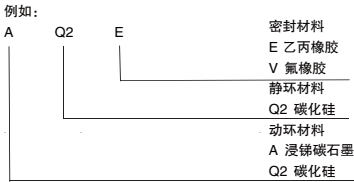

### 使用条件Working conditions

转速: 2960r/min, 1480r/min  
 流量范围: 8~1400m³/h  
 扬程: ≤127m  
 介质温度: -10°C~80°C  
 80°C~120°C (耐高温机封、轴承、O形密封圈)  
 环境温度: 最大+40°C; 海拔高度小于1000m; 相对湿度不超过95%  
 最大工作压力 (承压):

型号	工作压力	测试压力	承压零件材质
125口径 (2极转速) 及125口径以下	1.6MPa	2.1MPa	灰铁
125~200口径 (4极转速)	1.2MPa	1.6MPa	灰铁
250口径及250口径以上	1MPa	1.3MPa	灰铁
125口径 (4极转速) 及125口径以上	1.6MPa	2.1MPa	球铁, 订货需注明

最大工作压力=进口压力+闭阀压力 (Q=0)  
 最大进口压力

型号	扬程 (m)	最大进口压力 (MPa)	
		标准配置	球铁泵壳、高压机封
125口径 (2极转速) 及125口径以下	≤ 40	1.2	/
	≤ 60	1	/
	≤ 80	0.8	/
	≤ 125	0.4	/
125~200口径 (4极转速)	≤ 20	1	/
	≤ 40	0.8	1.2
	≤ 60	0.6	1
	≤ 80	0.4	0.8
250口径及250口径以上	≤ 20	0.8	1.2
	≤ 40	0.6	1.2
	≤ 60	0.4	1
	≤ 80	0.2	0.8

125口径 (2极转速) 及125口径以下小口径泵无需采用球铁材质, 表中打“/”号配置公司不再生产。

汽蚀余量是设计点实测值, 实际使用时应加0.5m的安全裕量。可选配PN16-GB/T17241.6-2008配对法兰。

Speed: 2960r/min, 1480r/min or 980r/min  
 Capacity range: 1.8~2000m³/h  
 Head: Up to 127m  
 Medium temperature: -10°C~ 80°C  
 Ambient temperature: Up to + 40°C;  
 Altitude<1000m; relative humidity ≤95%  
 Maximum working pressure:  
 Suction and discharge diameters are 125mm (2 pole speed) and below 125mm: 1.6Mpa;  
 Suction and discharge diameters are 125mm (4 pole speed) and 150~200mm: 1.2Mpa;  
 Suction and discharge diameters are greater than or equal to 250mm: 1.0Mpa;  
 Maximum operation pressure=Inlet pressure+valve shutting pressure.

### 型号说明Definition

例如: 80KQL50-32-7.5/2或80KQW50-32-7.5/2  
 KQL 标准立式单级泵, KQW 标准卧式单级泵  
 80 进出口直径  
 50 额定点流量  
 32 额定点扬程  
 7.5/2 电机功率/电机极数  
 For example: 80KQL50-32-7.5/2 or 80KQW50-32-7.5/2  
 KQL: Standard vertical single-stage pump  
 KQW: Standard horizontal single-stage pump  
 80: Suction and discharge nozzle nominal diameters  
 50: Capacity at rated point  
 32: Head at rated point  
 7.5/2: Motor power/motor pole

型号配置 MODEL	KQL 或 KQW	KQL/T 或 KQW/T
主要部件 MAIN PARTS		
电机系列 MOTOR	YE2系列超高效率三相异步电动机 Three-phase induction motor series	按客户要求 According to the customer's needs
泵轴材料 SHAFT	45#钢镀铬 45#Cr-plating	
轴承 BEARING	进口名牌 SKF	
机械密封 MECHANICAL SEAL	品牌 (35轴径及以下为合资品牌, 45轴径及以上为进口品牌) famous brand	
铸件 CASTING	优质铸件 Quality casting	
表面处理 SURFACE DISPOSE	200 及 200口径以下电泳漆处理后, 表面凯泉蓝	

### 材质Materials

泵体、泵盖、叶轮: 铸铁  
 泵轴: 45#钢镀铬  
 机械密封动、静环: 浸渍石墨、碳化硅

Materials  
 Casing, Cover, Impeller: Cast iron  
 Shaft: 45#Cr-plating  
 Motive, motionless ring of mechanical seal: Graphite, harden alloy

## 结构Structure

结构紧凑的单级泵，是最适用于现代建筑物的。

Compact single-stage pump is especially suitable for modern

### ——立式泵壳

管理连接型式的螺旋形泵壳，采用现代最优水力模型设计制造，进出口在同一直线上，且口径相同。法兰符合GB/T17241.6-2008并可选配Rp1/4或Rp3/8测压口。

### ——Casing

It has pipe joined spiral casing and uses the best hydraulic model. Suction and discharge nozzles are in one line with the same diameter. Flange accords with the standard of GB/T17241.6-1998 and may choose to be fixed with Rp1/4 or Rp3/8 pressure gauge.

### ——卧式泵壳

泵脚支承型式的螺旋形泵壳，采用现代最优水力模型设计制造，水平吸入，上方输出，且口径相同。法兰符合GB/T17241.6-2008并可选配Rp1/4或Rp3/8测压口。

### ——Casing

It has pipe joined spiral casing and uses the best hydraulic model. Suction and discharge nozzles are in one line with the same diameter. Flange accords with the standard of GB/T17241.6-1998 and may choose to be fixed with Rp1/4 or Rp3/8 pressure gauge.

### ——叶轮

闭式叶轮，优秀的水力模型保证泵的效率 and 可靠性，部分改进型号泵的配套功率下降一档。

### ——Impeller

Closed cast iron impeller. Best hydraulic model guarantees the efficiency and reliability of the pump.

## 机械密封Mechanical seal

### 系列产品

用于水温80℃以下免保养，并不受转向限制。特殊波纹管设计保证了动环的补偿性和密封性能。

### Series product.

If the pump operates in the water with temperature below 80℃, it needn't maintain and will not be limited by rotating direction. Special bellows design guarantees the compensation and hermetic function of the dynamic ring.

## 电机Motor

YE3系列超高效率三相异步电动机系列。功率和型式符合IEC-Norm.

型式: V1 (KQL) B35 (KQW)

电源: 380V, 50HZ

防护等级: IP55

绝缘等级: F

电机轴: 45#钢镀铬或不锈钢 (2Cr13)

温度: 电机工作环境温度最大到40℃。温度高于40℃时，请降低功率使用。

转向: 立式泵从电机风叶端向下看为顺时针方向，卧式泵从泵进口方向看为逆时针方向。

Squirrel three-phase induction motor series. Efficiency and type accord with ICE-Norm.

Type: V1 (KQL) B35 (KQW)

Power source: 380V, 50HZ

Protection class: IP55

Insulation: F

Shaft of the motor: Stainless steel(2Cr13)

Temperature: Maximum temperature of working environment is 40℃. Above 40℃, please decrease the power.

## 泵机组优点Advantages

——采用电机直接连接，机泵轴完全同心，振动小、噪音低

——泵进出口口径相同，运行稳定可靠。

——用整轴和特殊结构配置的SKF轴承，运行可靠。

——用强制环流的不受转向限制的特殊结构配置的机械密封，改善其运行环境，延长使用寿命。

——独特的安装结构大大缩小了泵的占地面积，节约建设投资40%~60%。

——完美的设计确保泵的无泄漏，长寿命运行，节约运行管理费50%~70%。

——采用优质铸件，尺寸精度高，外形美观。

电机优点:

——采用更新设计的超高效率三相异步电动机系列，结构更加合理，外形新颖美观。

——启动转矩大，效率高，噪音小。

——F级绝缘，提高了电机使用的最高允许温升，因而抗过载能力高，耐力强，使用安全可靠，寿命延长。

——IP55全封闭结构，防止粉尘、风雨、飞溅水滴等进入电机内部，造成电机损坏。

——不锈钢转轴，永不生锈，保证配合零件拆装简便，机械密封波纹管密封可靠。



- Directly connected with the motor. the axle of motor and pump share the same shaft. Less vibration, Low noise.
- The outlet and inlet are same in diameter and the diameters are in the same line. Liquid flows smoothly with less loss.
- Removal of baseplate. Just like valves, the pump can be mounted wherever on the pipe line.
- The whole shaft and special structured configuration bearing runs reliably.
- The mechanical seal, which applies the configuration of end-to-end circulation and no direct-ionlimited special structure, improves the running environment and elongate the service life.
- Unique in stallation reduces the occupation of pump, which saves the invest cost by 40% to 60%.
- Perfect design makes sure of no leakage, long life, which saves operation cost by 50% to 70%.
- Adopt the high-quality casting off, which results in high accuracy in dimension and nice-looking appearance.

#### Motor Advantages

- Adopt the modified Two-phase induction, the structure is more reasonable and, rational and nice-looking.
- The starting torque is large, the efficiency is high, the noise is low.
- F class insulation, which improves the permissible temperature rise of motor, thus resulting in high ability the antioverload, strong wear-resistant, and long service life.
- Ip 55 fully close structure, which prevents dust, water drop, rain (with cover) from entering the motor to damage the motor.

- Rotating shaft made of stainless material; will never be rusted, which ensures that the components are easy to dismantle, and the ripple pipe of mechanical seal is reliable.

### 供货范围 Supply Arrange

水泵带底座（板）和安装使用说明书  
Pump and installation instructions are available.

### 订货须知 Notes on Order-placing

1. 输送特殊液体时，请在合同中注明液体的名称。温度、密度、浓度、粘性等，以便制造厂合理选配材质和电机功率。
  2. 当对流量、扬程、进口压力、电机电压、频率、防爆等有特殊要求时，请在合同中注明。
1. Name, temperature, density, concentration, trellises should be clearly noted in the contract when the transporting media is corrosive, so that the manufacturer can make a proper choice of material and power of motor.
  2. It should be clearly noted in the contract when special requirement, for instance, capacity, suction pressure, head, motor, voltage, frequency, blast-proof etc, are made.

型谱图HYDRAULIC COVERAGE

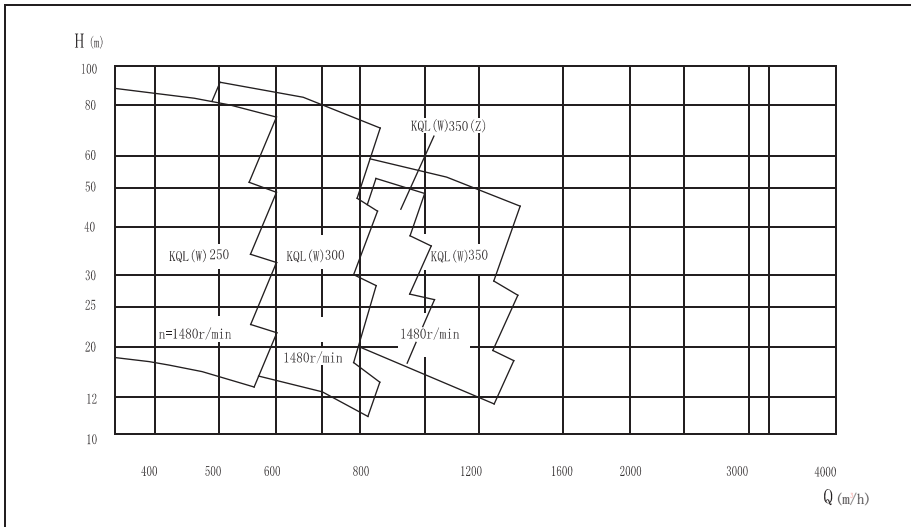
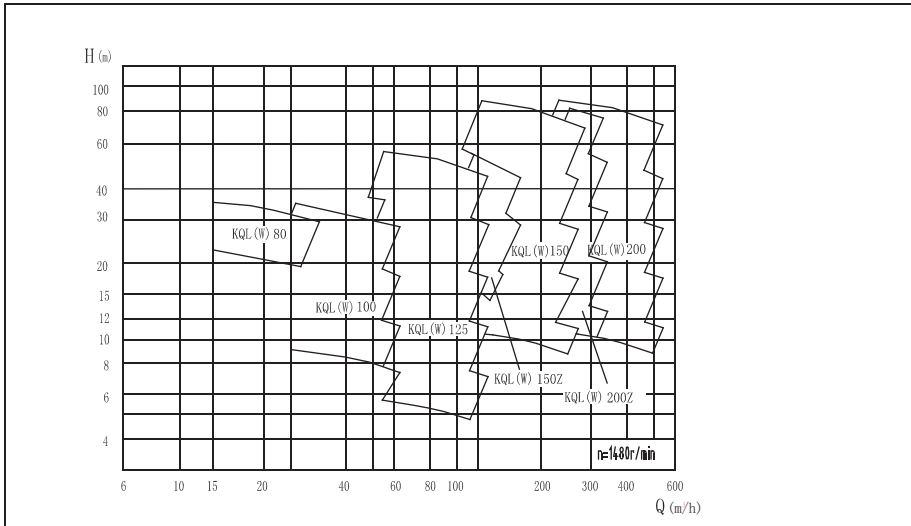
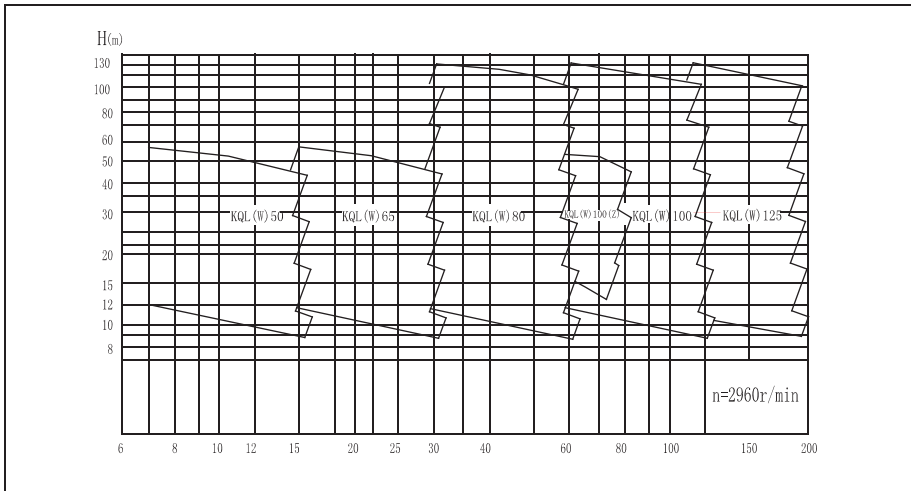



**KQL结构图KQL STRUCTURE DRAWING**

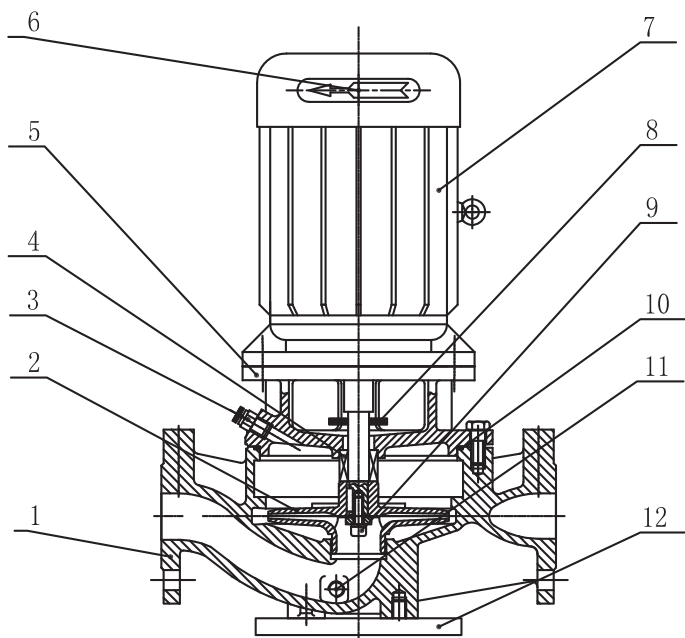

序号 No.	数量 QUANTITY	名称 NAME
1	1	泵体 Casing
2	1	叶轮 Impeller
3	1	放气旋塞 Air discharge valve
4	1	机械密封 Mechanical seal
5	1	泵盖 Casing cover
6	1	转向牌 Chang direction plate
7	1	电机 Motor
8	1	挡水圈 Deflector
9	1	螺钉 Screw
10	1	O形密封圈 O seal ring
11	1	螺塞 Plug
12	1	底板 Baseplate

**KQW结构图KQW STRUCTURE DRAWING**

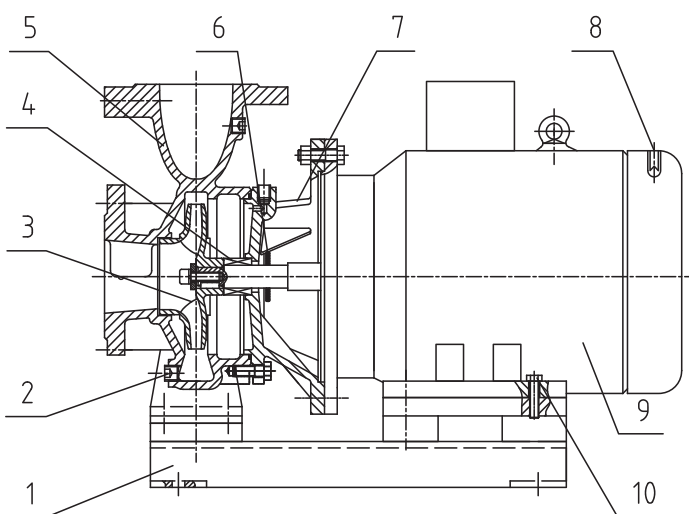

序号 No.	数量 QUANTITY	名称 NAME
1	1	底座 Bedplate
2	3	螺塞 Screwed plug
3	1	叶轮 Impeller
4	1	机械密封 Mechanical seal
5	1	泵体 Pump body
6	1	挡水圈 Deflector
7	1	泵盖 Pump Cover
8	1	转向牌 Chang direction plate
9	1	电动机 Motor
10	8	螺栓 Bolt

## 性能曲线CHARACTERISTIC CURVE

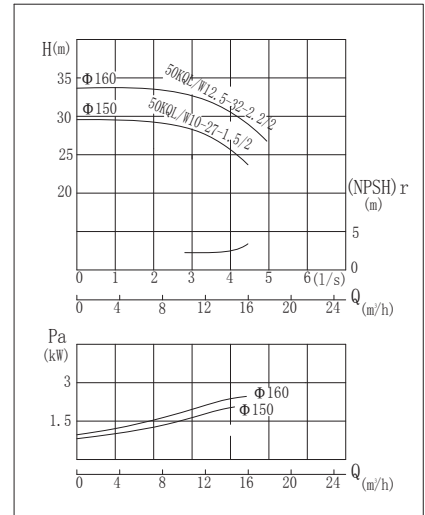
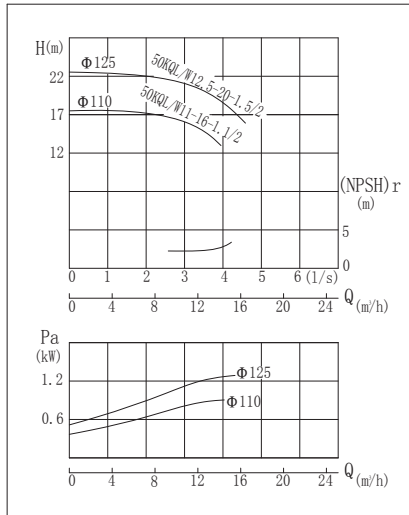
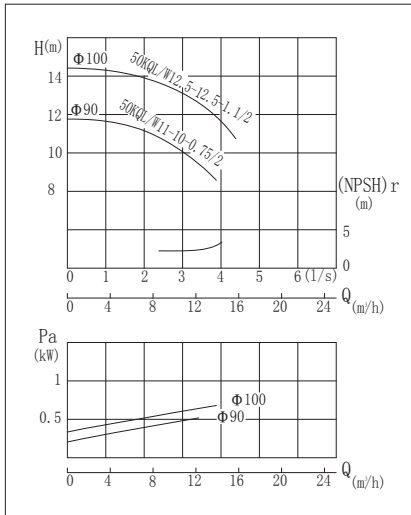

## 尺寸图DIMENSION FIGURE

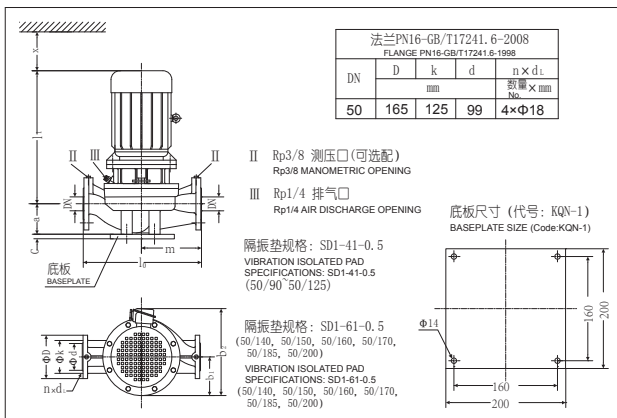

## KQL尺寸表DIMENSION TABLE

型号 TYPE	DN	l <sub>0</sub>	m	a	c	l <sub>1</sub>	b <sub>1</sub>	b <sub>2</sub>	x
		mm							
50KQL10-11-0.75/2	50	370	185	115	24	395	120	265	100
50KQL12.5-12.5-1.1/2	50	370	185	115	24	395	120	265	100
50KQL11-16-1.1/2	50	370	185	115	24	395	120	265	100
50KQL12.5-20-1.5/2	50	370	185	115	24	440	155	280	100
50KQL10-27-1.5/2	50	370	185	115	24	440	120	280	100
50KQL12.5-32-2.2/2	50	370	185	115	24	470	120	280	100
50KQL10-36-3/2	50	380	190	127	24	513	155	325	120
50KQL12-44-4/2	50	380	190	127	24	548	155	345	120
50KQL12.5-50-5.5/2	50	380	190	127	24	578	185	400	120

### 性能曲线CHARACTERISTIC CURVE

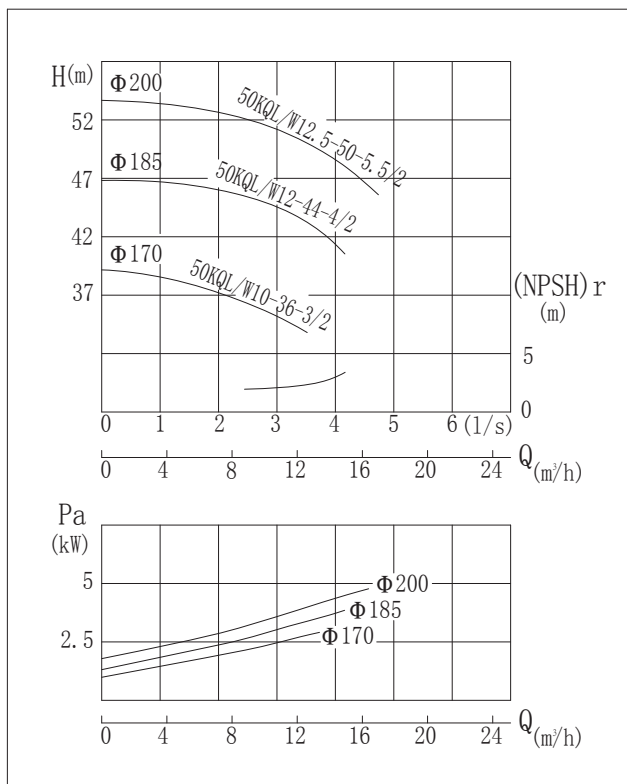

### 参数表PERFORMANCE DATA

型号 TYPE	流量 Capacity		扬程 Head (m)	转速 Speed (r/min)	效率 Efficiency (%)	电机 功率 Power (kW)	必需汽蚀 余量 (NPSH)r (m)	重量 Weight (kg)
	(m <sup>3</sup> /h)	(l/s)						
50KQL/W11-10-0.75/2	8	2.22	11	2960	66	0.75	2.3	38
	11	3.05	10					
	13.2	3.67	9					
50KQL/W12.5-12.5-1.1/2	8.8	2.44	13.6	2960	66.2	1.1	2.3	40
	12.5	3.47	12.5					
	15	4.17	11.3					
50KQL/W11-16-1.1/2	8	2.22	17	2960	61	1.1	2.3	40
	11	3.05	16					
	13.2	3.67	14					
50KQL/W12.5-20-1.5/2	8.8	2.44	21.5	2960	62.1	1.5	2.3	48
	12.5	3.47	20					
	15	4.17	17.8					
50KQL/W10-27-1.5/2	7.0	1.94	28.35	2960	55	1.5	2.3	51
	10	2.78	27					
	11.0	3.06	26.2					
50KQL/W12.5-32-2.2/2	8.8	2.43	33.6	2960	56	2.2	2.3	59
	12.5	3.47	32					
	13.8	3.82	30					
50KQL/W10-36-3/2	7.3	2.02	38	2960	48	3	2.3	65
	10.4	2.89	36					
	12.5	3.47	33					
50KQL/W12-44-4/2	8.3	2.31	45.8	2960	49	4	2.3	80
	11.7	3.25	44					
	14.0	3.89	42					
50KQL/W12.5-50-5.5/2	8.8	2.43	52	2960	49.5	5.5	2.3	105
	12.5	3.47	50					
	15.0	4.17	48					

### 尺寸图DIMENSION FIGURE

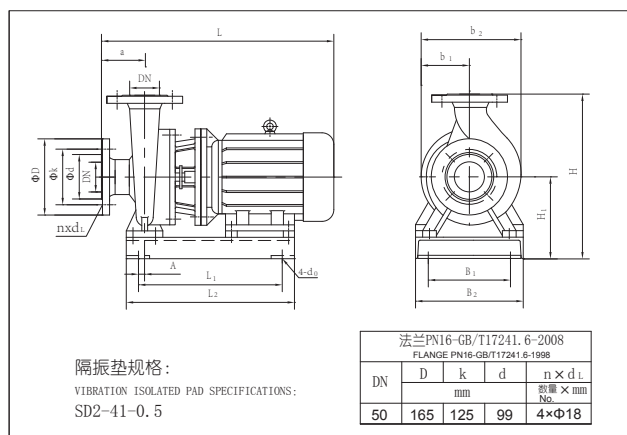

### KQW尺寸表DIMENSION TABLE

型号 TYPE	外形尺寸 Figure dimensions				安装尺寸 Installing dimensions								DN
	L	H	b <sub>2</sub>	b <sub>1</sub>	4-φ <sub>0</sub>	a	L <sub>1</sub>	B <sub>1</sub>	L <sub>2</sub>	B <sub>2</sub>	H <sub>1</sub>	A	
50KQW10-11-0.75/2	475	379	250	125	4-φ12	80	245	160	345	250	219	0	50
50KQW12.5-12.5-1.1/2	475	379	250	125	4-φ12	80	245	160	345	250	219	0	50
50KQW11-16-1.1/2	475	379	250	125	4-φ12	80	245	160	345	250	219	0	50
50KQW12.5-20-1.5/2	520	379	250	125	4-φ12	80	255	160	360	250	219	0	50
50KQW10-27-1.5/2	520	379	250	125	4-φ12	80	255	160	360	250	219	0	50
50KQW12.5-32-2.2/2	550	379	250	125	4-φ12	80	280	160	385	250	219	0	50
50KQW10-36-3/2	613	502	320	160	4-φ15	100	325	220	425	320	277	12.5	50
50KQW12-44-4/2	648	502	320	160	4-φ15	100	335	220	435	320	277	12.5	50
50KQW12.5-50-5.5/2	678	502	320	160	4-φ15	100	370	220	470	320	277	12.5	50

## 性能曲线CHARACTERISTIC CURVE

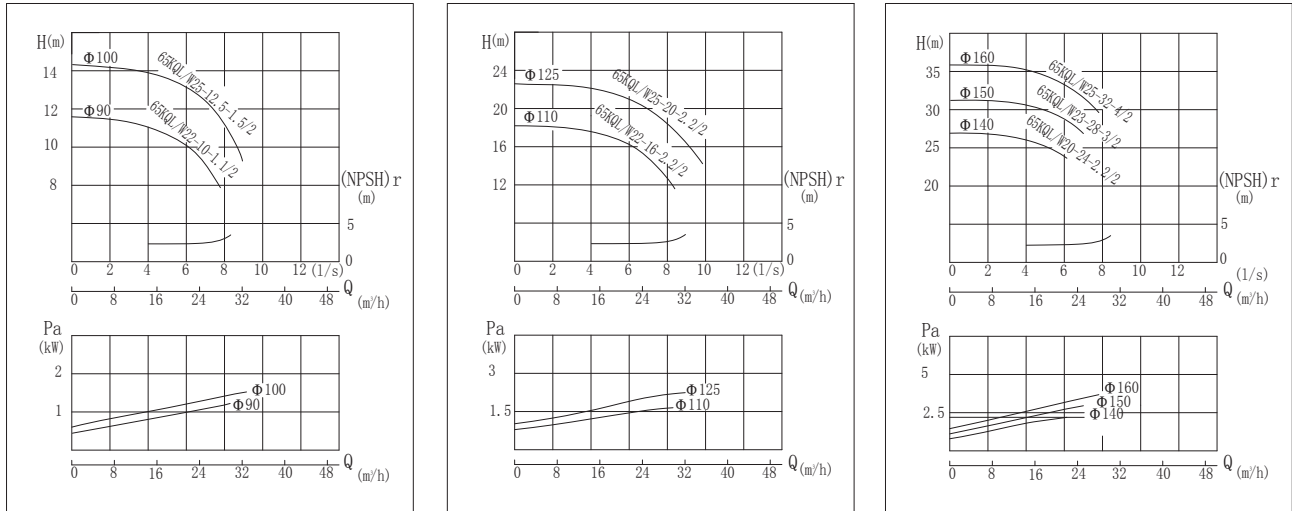

## 尺寸图DIMENSION FIGURE

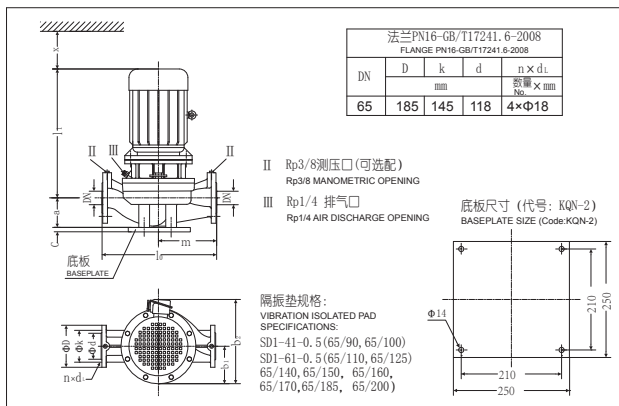

## KQL尺寸表DIMENSION TABLE

型号 TYPE	DN	$l_0$	$m$	$a$	$c$	$l_1$	$b_1$	$b_2$	$x$
		mm							
65KQL22-10-1.1/2	65	420	210	130	30	395	120	265	105
65KQL25-12.5-1.5/2	65	420	210	130	30	440	120	280	105
65KQL22-16-2.2/2	65	420	210	130	30	470	120	280	105
65KQL25-20-2.2/2	65	420	210	130	30	470	120	280	105
65KQL20-24-2.2/2	65	420	210	130	30	470	120	280	105
65KQL23-28-3/2	65	420	210	130	30	505	125	295	105
65KQL25-32-4/2	65	420	210	130	30	540	125	315	105
65KQL22-38-5.5/2	65	400	200	150	30	577	185	400	105
65KQL23-44-5.5/2	65	400	200	150	30	577	185	400	105
65KQL25-50-7.5/2	65	400	200	150	30	577	185	400	105



### 性能曲线CHARACTERISTIC CURVE

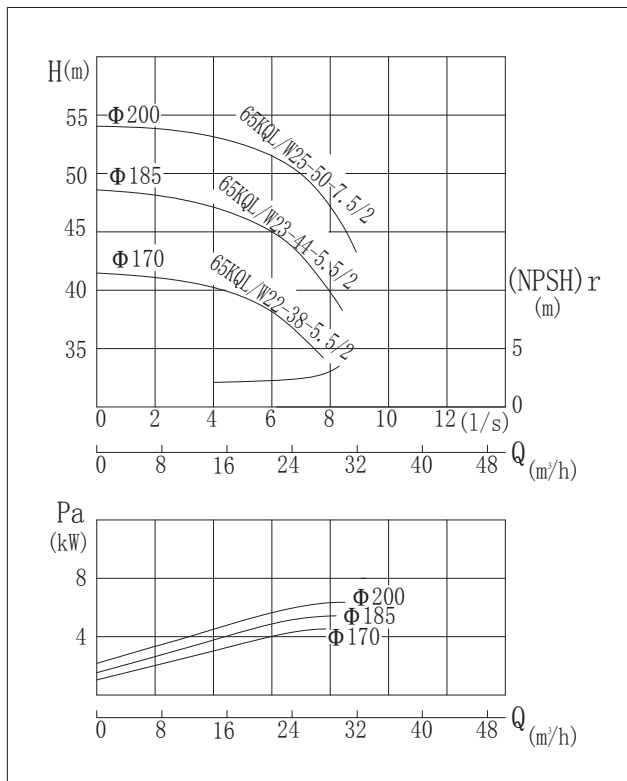

### 参数表PERFORMANCE DATA

型号 TYPE	流量 Capacity		扬程 Head (m)	转速 Speed (r/min)	效率 Efficiency (%)	电机 功率 Power (kW)	必需汽蚀 余量 (NPSH)r (m)	重量 Weight (kg)
	(m³/h)	(l/s)						
65KQL/W22-10-1.1/2	15.6	4.3	11	2960	65	1.1	2.5	31
	22.3	6.19	10					
	27	7.5	8.4					
65KQL/W25-12.5-1.5/2	17.5	4.86	13.7	2960	65.5	1.5	2.5	53
	25	6.94	12.5					
	30	8.33	10.5					
65KQL/W22-16-2.2/2	15.6	4.3	17	2960	65	2.2	2.5	58
	22.3	6.19	16					
	27	7.5	14.4					
65KQL/W25-20-2.2/2	17.5	4.86	21	2960	71.4	2.2	2.5	64
	25	6.94	20					
	27.5	7.64	18.5					
65KQL/W20-24-2.2/2	14	3.89	25.2	2960	65	2.2	2.5	64
	20	6	24					
	22	6.11	23.2					
65KQL/W23-28-3/2	16.1	4.47	29.4	2960	66	3	2.5	75
	23	6.5	28					
	25.3	7.03	26.8					
65KQL/W25-32-4/2	17.5	4.86	34.3	2960	66.7	4	2.5	73
	25	6.94	32					
	30	8.33	28.5					
65KQL/W22-38-5.5/2	15.2	4.22	40	2960	57	5.5	2.5	100
	21.8	6.06	38					
	26.2	7.27	34.5					
65KQL/W23-44-5.5/2	16.4	4.55	46.2	2960	58	5.5	2.5	107
	23.4	6.5	44					
	25.7	7.15	39.6					
65KQL/W25-50-7.5/2	17.5	4.86	52.7	2960	59	7.5	2.5	107
	25	6.94	50					
	30	8.33	45.5					

### 尺寸图DIMENSION FIGURE

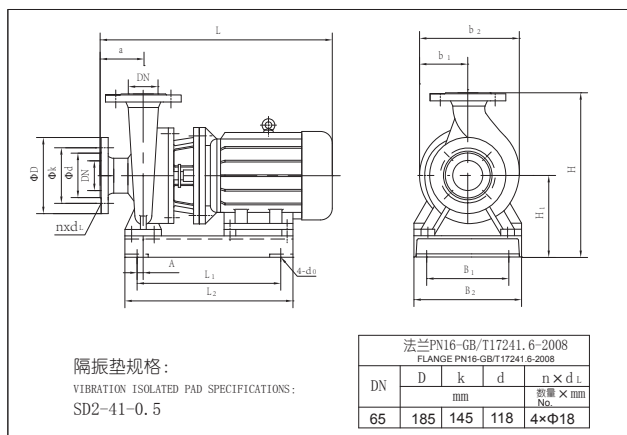

### KQW尺寸表DIMENSION TABLE

型号 TYPE	外形尺寸 Figure dimensions				安装尺寸 Installing dimensions								DN
	L	H	b <sub>2</sub>	b <sub>1</sub>	4-φ <sub>0</sub>	a	L <sub>1</sub>	B <sub>1</sub>	L <sub>2</sub>	B <sub>2</sub>	H <sub>1</sub>	A	
65KQW22-10-1.1/2	475	409	250	125	4-φ12	80	245	160	345	250	219	0	65
65KQW25-12.5-1.5/2	520	409	250	125	4-φ12	80	255	160	360	250	219	0	65
65KQW22-16-2.2/2	550	409	250	125	4-φ12	80	280	160	385	250	219	0	65
65KQW25-20-2.2/2	550	409	250	125	4-φ12	80	280	160	385	250	219	0	65
65KQW20-24-2.2/2	550	409	250	125	4-φ12	80	280	160	385	250	219	0	65
65KQW23-28-3/2	585	409	250	125	4-φ12	80	300	160	405	250	219	0	65
65KQW25-32-4/2	620	409	250	125	4-φ12	80	310	160	410	250	219	0	65
65KQW22-38-5.5/2	677	507	320	160	4-φ15	100	370	220	470	320	277	12.5	65
65KQW23-44-5.5/2	677	507	320	160	4-φ15	100	370	220	470	320	277	12.5	65
65KQW25-50-7.5/2	677	507	320	160	4-φ15	100	370	220	470	320	277	12.5	65

## 性能曲线CHARACTERISTIC CURVE

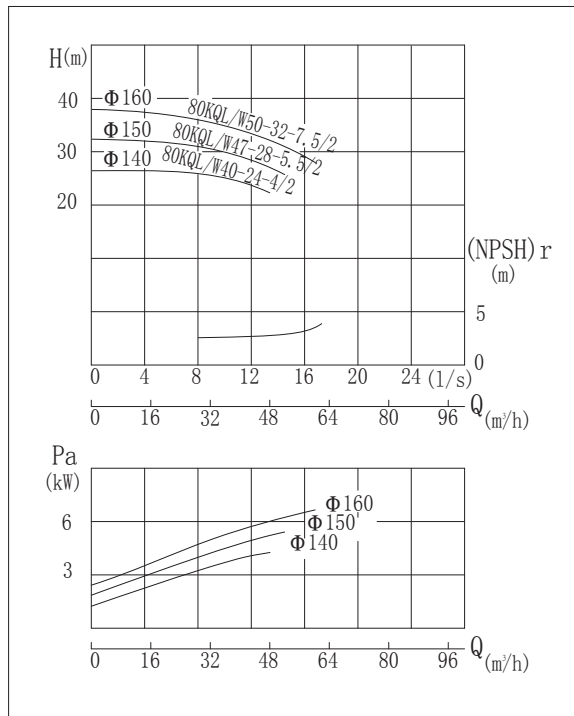
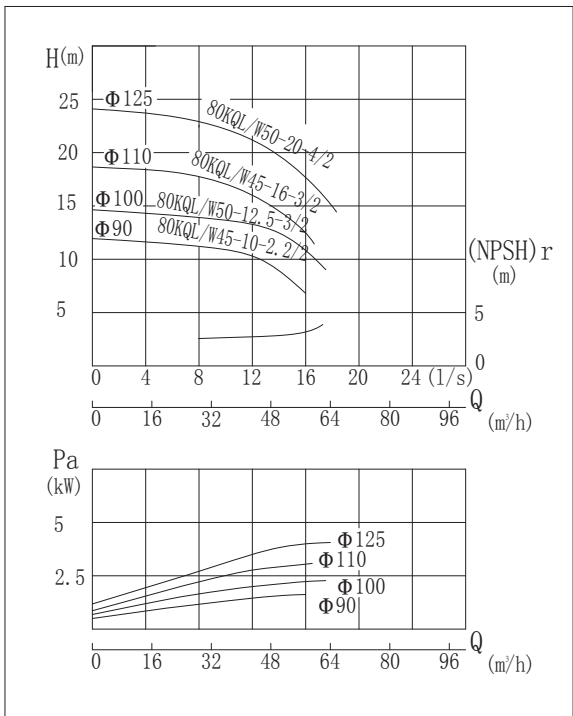

## 尺寸图DIMENSION FIGURE

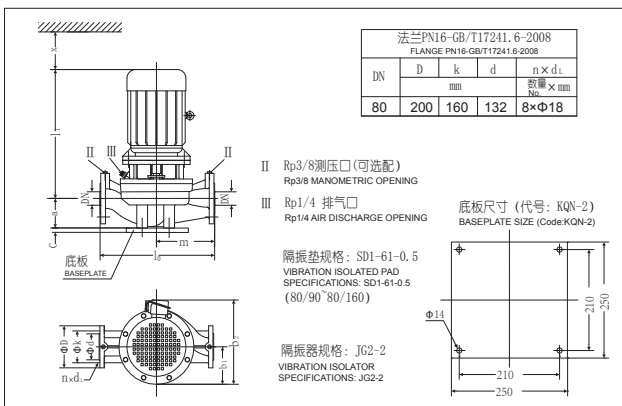

## KQL尺寸表DIMENSION TABLE

型号 TYPE	DN	l <sub>0</sub>	m	a	c	l <sub>1</sub>	b <sub>1</sub>	b <sub>2</sub>	x
		mm							
80KQL45-10-2.2/2	80	490	245	145	30	470	120	290	110
80KQL50-12.5-3/2	80	490	245	145	30	505	125	295	110
80KQL45-16-3/2	80	490	245	145	30	505	125	295	110
80KQL50-20-4/2	80	490	245	145	30	540	125	315	110
80KQL40-24-4/2	80	490	245	145	30	540	125	315	110
80KQL47-28-5.5/2	80	490	245	145	30	560	185	400	110
80KQL50-32-7.5/2	80	490	245	145	30	560	185	400	110
80KQL35-34-5.5/2	80	490	245	145	30	560	185	400	110
80KQL44-38-7.5/2	80	540	270	155	30	577	185	400	120
80KQL47-44-11/2	80	540	270	155	30	705	225	485	120
80KQL50-50-15/2	80	540	270	155	30	705	225	485	120

### 性能曲线CHARACTERISTIC CURVE

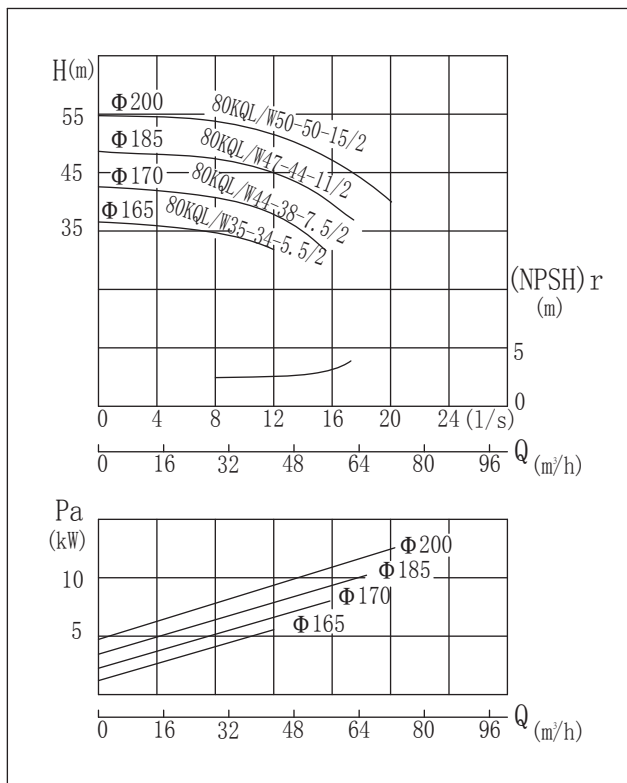

### 参数表PERFORMANCE DATA

型号 TYPE	流量 Capacity		扬程 Head (m)	转速 Speed (r/min)	效率 Efficiency (%)	电机 功率 Power (kW)	必需汽蚀 余量 (NPSH)r (m)	重量 Weight (kg)
	(m³/h)	(l/s)						
80KQL/W45-10-2.2/2	31.3	8.7	11.5	2960	72	2.2	3	63
	44.7	12.5	10					
	53.6	14.9	8					
80KQL/W50-12.5-3/2	35	9.72	14	2960	73	3	3	80
	50	13.9	12.5					
	60	16.7	10.1					
80KQL/W45-16-3/2	31.5	8.75	17.5	2960	76.4	3	3	79
	45	12.5	16					
	49.5	13.75	15					
80KQL/W50-20-4/2	35	9.72	21	2960	76.9	4	3	90
	50	13.9	20					
	55	15.28	18.3					
80KQL/W40-24-4/2	28	7.78	25.2	2960	75	4	3	90
	40	12	24					
	44	12.22	21.6					
80KQL/W47-28-5.5/2	32.69	9.08	30	2960	75	5.5	3	110
	46.7	13	28					
	51.37	14.27	25.8					
80KQL/W50-32-7.5/2	35	9.72	35	2960	75.4	7.5	3	113
	50	13.9	32					
	60	16.7	28					
80KQL/W35-34-5.5/2	24.5	6.81	35.7	2960	70	5.5	3	112
	35	9.72	34					
	38.5	10.69	32					
80KQL/W44-38-7.5/2	30.5	8.5	40.6	2960	70	7.5	3	115
	43.5	12.1	38					
	52	14.4	33.4					
80KQL/W47-44-11/2	32.8	9.1	47	2960	70	11	3	165
	47	13.1	44					
	56.4	15.7	40					
80KQL/W50-50-15/2	35	9.72	53.5	2960	71.4	15	3	185
	50	13.9	50					
	60	16.67	46					

### 尺寸图DIMENSION FIGURE

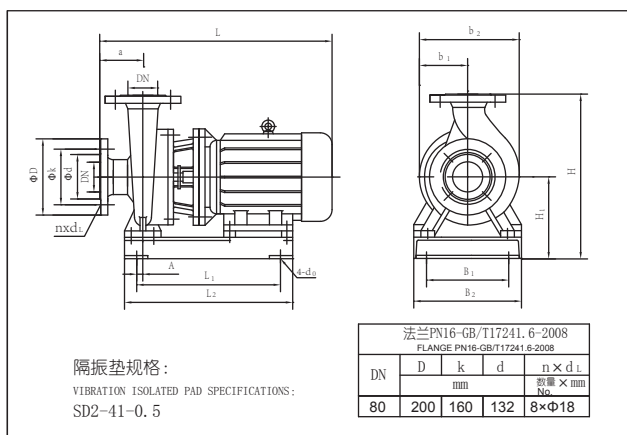

### KQW尺寸表DIMENSION TABLE

型号 TYPE	外形尺寸 Figure dimensions				安装尺寸 Installing dimensions								DN
	L	H	b <sub>2</sub>	b <sub>1</sub>	4-d <sub>0</sub>	a	L <sub>1</sub>	B <sub>1</sub>	L <sub>2</sub>	B <sub>2</sub>	H <sub>1</sub>	A	
80KQW45-10-2.2/2	570	457	256	125	4-Φ12	100	290	160	390	250	247	0	80
80KQW50-12.5-3/2	605	457	256	125	4-Φ12	100	300	160	400	250	247	0	80
80KQW45-16-3/2	605	457	256	125	4-Φ12	100	300	160	400	250	247	0	80
80KQW50-20-4/2	640	457	256	125	4-Φ12	100	310	160	410	250	247	0	80
80KQW40-24-4/2	640	457	256	125	4-Φ12	100	310	160	410	250	247	0	80
80KQW47-28-5.5/2	670	461	300	150	4-Φ15	100	350	180	450	280	251	0	80
80KQW50-32-7.5/2	670	461	300	150	4-Φ15	100	350	180	450	275	251	0	80
80KQW35-34-5.5/2	670	461	300	150	4-Φ15	100	350	180	450	280	251	0	80
80KQW44-38-7.5/2	700	527	323	160	4-Φ15	125	370	220	470	330	277	12.5	80
80KQW47-44-11/2	842	527	350	175	4-Φ15	125	470	220	570	330	277	12.5	80
80KQW50-50-15/2	840	527	350	175	4-Φ15	125	470	220	570	320	277	12.5	80

## 性能曲线CHARACTERISTIC CURVE

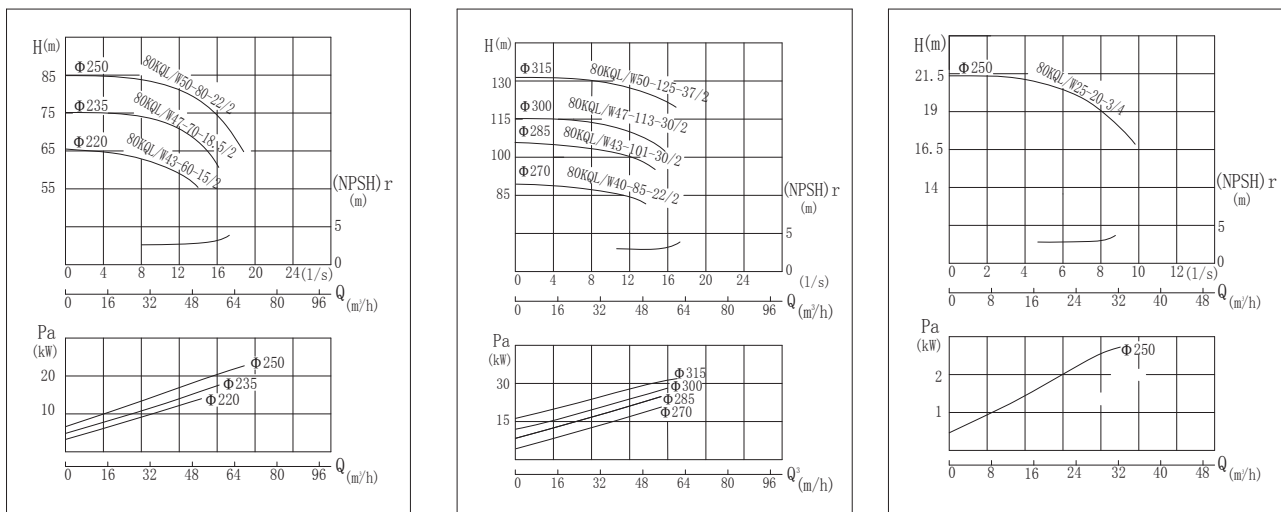

## 尺寸图DIMENSION FIGURE

## KQL尺寸表DIMENSION TABLE

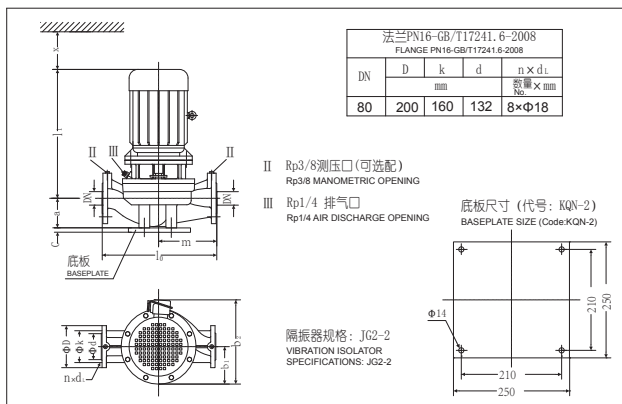

型号 TYPE	DN	l <sub>0</sub>	m	a	c	l <sub>1</sub>	b <sub>1</sub>	b <sub>2</sub>	x
		mm							
80KQL43-60-15/2	80	540	270	155	30	705	225	485	120
80KQL47-70-18.5/2	80	540	270	155	30	735	225	485	120
80KQL50-80-22/2	80	540	270	155	30	775	250	530	120

## 尺寸图DIMENSION FIGURE

## KQL尺寸表DIMENSION TABLE

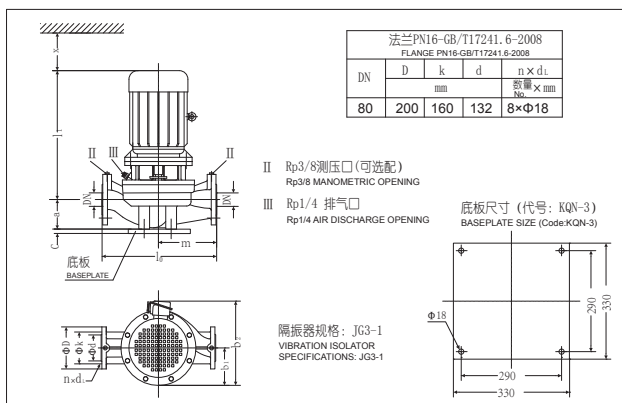

型号 TYPE	DN	l <sub>0</sub>	m	a	c	l <sub>1</sub>	b <sub>1</sub>	b <sub>2</sub>	x
		mm							
80KQL40-85-22/2	80	600	290	175	30	790	200	430	120
80KQL43-101-30/2	80	600	290	175	30	840	210	545	120
80KQL47-113-30/2	80	600	290	175	30	840	210	545	120
80KQL50-125-37/2	80	600	290	175	30	840	210	545	120
80KQL25-20-3/4	80	540	270	155	30	521	155	335	120
80KQL23-28-4/4	80	600	290	175	30	570	210	545	120
80KQL25-32-5.5/4	80	600	290	175	30	590	210	545	120



### 性能曲线CHARACTERISTIC CURVE

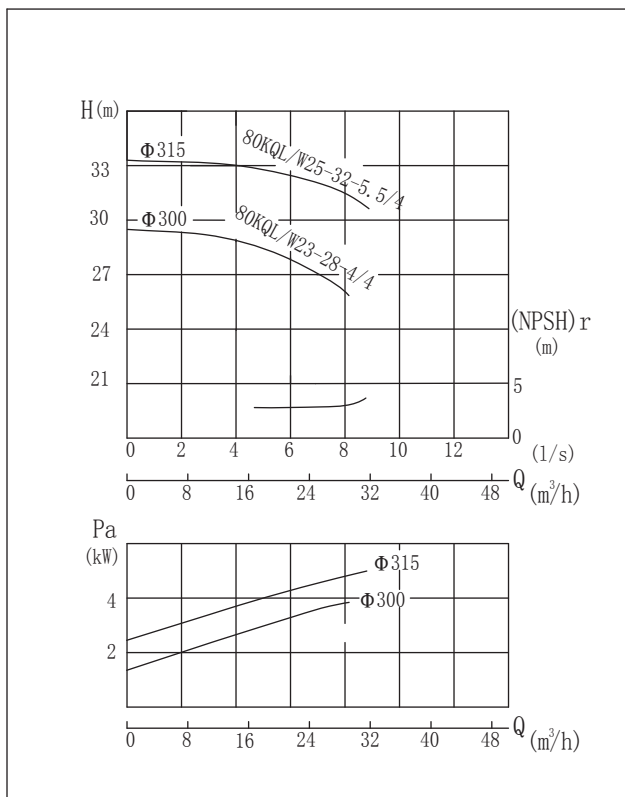

### 参数表PERFORMANCE DATA

型号 TYPE	流量 Capacity		扬程 Head (m)	转速 Speed (r/min)	效率 Efficiency (%)	电机 功率 Power (kW)	必需汽蚀 余量 (NPSH)r (m)	重量 Weight (kg)
	(m³/h)	(l/s)						
80KQL/W43-60-15/2	30	8.3	62	2960	61	15	3	186
	43.3	12	60					
	52	14.4	54					
80KQL/W47-70-18.5/2	32.5	9	73	2960	62	18.5	3	205
	46.7	13	70					
	56	15.6	63					
80KQL/W50-80-22/2	35	9.72	83	2960	63	22	3	240
	50	13.9	80					
	60	16.7	72					
80KQL/W40-85-22/2	28	7.78	88	2960	54	22	3	249
	40	11.1	85					
	48	13.3	78					
80KQL/W43-101-30/2	30	8.3	105	2960	55	30	3	380
	43.3	12	101					
	52	14.4	94					
80KQL/W47-113-30/2	32.5	9	117	2960	56	30	3	380
	46.7	13	113					
	56	15.6	106					
80KQL/W50-125-37/2	35	9.72	129	2960	57	37	3	450
	50	13.9	125					
	60	16.7	118					
80KQL/W25-20-3/4	15	4.17	21	1480	59	3	2.8	145
	25	6.94	20					
	30	8.33	18.3					
80KQL/W23-28-4/4	14	3.89	28.3	1480	52	4	2.8	260
	23	6.39	27.9					
	28	7.78	25.3					
80KQL/W25-32-5.5/4	15	4.17	33	1480	52.6	5.5	2.8	277
	25	6.94	32					
	30	8.33	30					

### 尺寸图DIMENSION FIGURE

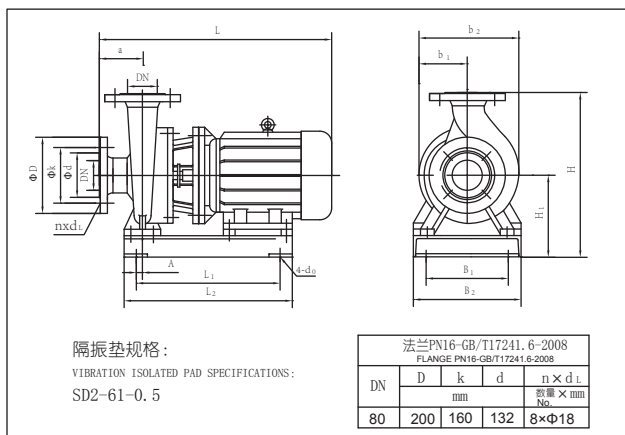

### KQW尺寸表DIMENSION TABLE

型号 TYPE	外形尺寸 Figure dimensions		安装尺寸 Installing dimensions										DN
	L	H	b <sub>2</sub>	b <sub>1</sub>	4-φ <sub>0</sub>	a	L <sub>1</sub>	B <sub>1</sub>	L <sub>2</sub>	B <sub>2</sub>	H <sub>1</sub>	A	
80KQW43-60-15/2	840	527	350	175	4-φ15	125	470	220	570	330	277	12.5	80
80KQW47-70-18.5/2	870	527	350	175	4-φ15	125	510	220	610	330	277	12.5	80
80KQW50-80-22/2	910	535	380	190	4-φ15	125	515	260	615	370	285	12.5	80
80KQW40-85-22/2	925	620	393	190	4-φ15	125	520	260	620	360	330	12.5	80
80KQW43-101-30/2	975	619	420	210	4-φ15	125	610	300	710	400	329	12.5	80
80KQW47-113-30/2	975	619	420	210	4-φ15	125	610	300	710	400	329	12.5	80
80KQW50-125-37/2	975	619	420	210	4-φ15	125	610	300	710	400	329	12.5	80
80KQW25-20-3/4	645	527	323	160	4-φ15	125	315	220	425	320	277	10	80
80KQW23-28-4/4	675	620	392	189	4-φ15	125	315	280	440	360	330	10	80
80KQW25-32-5.5/4	705	620	392	189	4-φ15	125	395	280	470	360	330	20	80

## 性能曲线CHARACTERISTIC CURVE

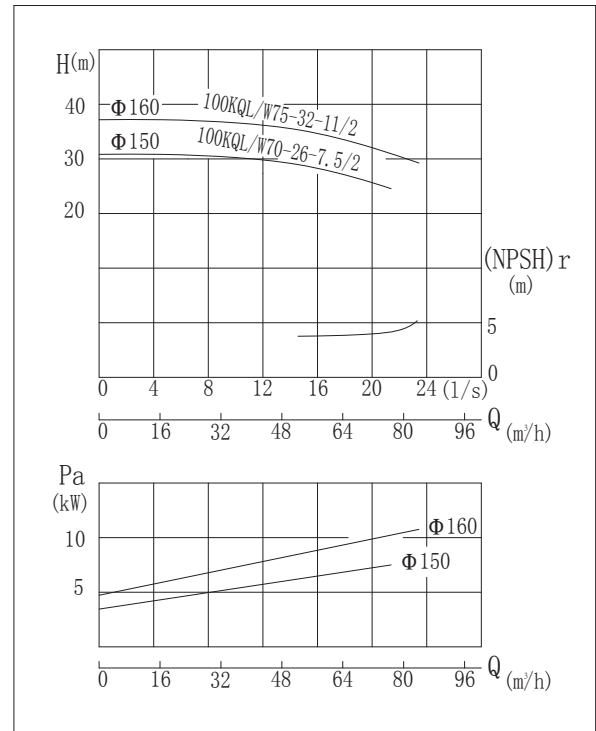
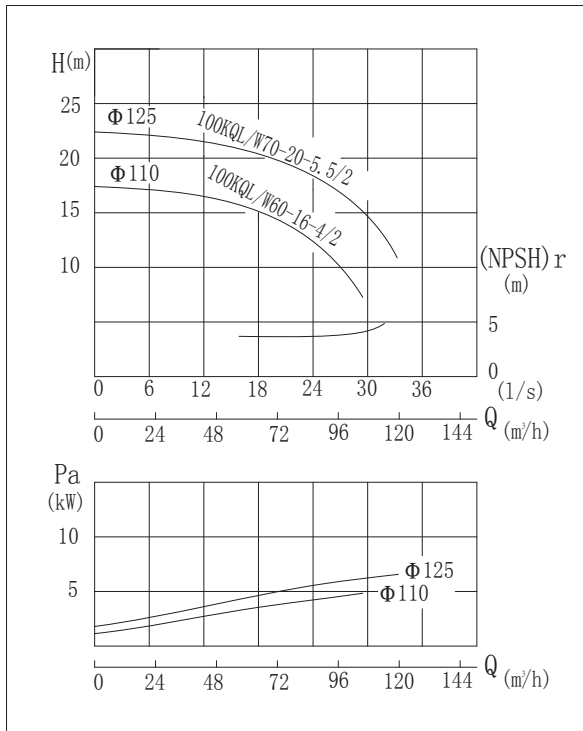

## 尺寸图DIMENSION FIGURE

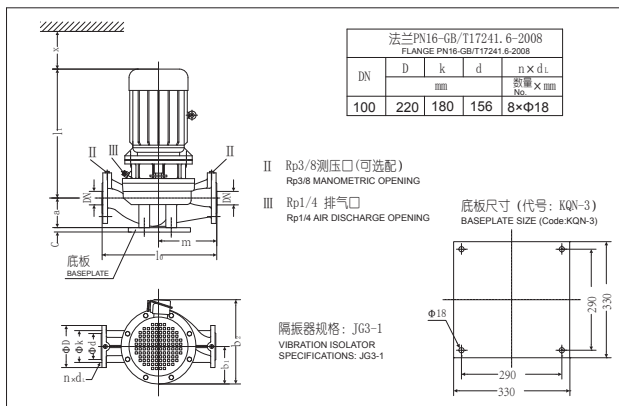

## KQL尺寸表DIMENSION TABLE

型号 TYPE	DN	$l_0$	$m$	$a$	$c$	$l_1$	$b_1$	$b_2$	$x$
		mm							
100KQL60-16-4/2	100	580	280	180	30	560	125	315	130
100KQL70-20-5.5/2	100	580	280	180	30	580	185	400	130
100KQL70-26-7.5/2	100	580	280	180	30	580	185	400	130
100KQL75-32-11/2	100	580	280	180	30	710	225	485	130
100KQL68-38-11/2	100	580	280	180	30	720	225	485	130
100KQL72-44-15/2	100	580	280	180	30	720	225	485	130
100KQL75-50-18.5/2	100	580	280	180	30	750	225	485	130

性能曲线CHARACTERISTIC CURVE

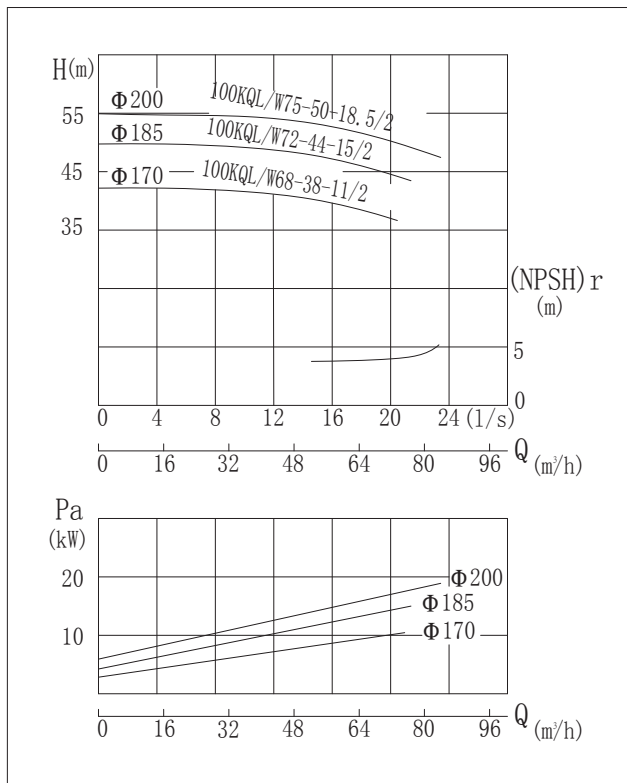

参数表PERFORMANCE DATA

型号 TYPE	流量 Capacity		扬程 Head (m)	转速 Speed (r/min)	效率 Efficiency (%)	电机 功率 Power (kW)	必需汽蚀 余量 (NPSH)r (m)	重量 Weight (kg)
	3 (m³/h)	l/s)						
100KQL/W60-16-4/2	42	11.7	17.5	2960	77	4	4.5	91
	60	16.7	16					
	66	18.3	14.8					
100KQL/W70-20-5.5/2	49	13.6	22	2960	78	5.5	4.5	115
	70	19.4	20					
	77	21.4	18.5					
100KQL/W70-26-7.5/2	49	13.6	27.3	2960	77	7.5	4.5	132
	70	19.4	26					
	77	21.4	24.3					
100KQL/W75-32-11/2	52.5	14.6	34.5	2960	78	11	4.5	178
	75	20.8	32					
	82.5	22.9	29.3					
100KQL/W68-38-11/2	47.6	13.2	41	2960	74	11	4	179
	68	18.9	38					
	74.8	20.8	34.2					
100KQL/W72-44-15/2	50.4	14.0	48.5	2960	75	15	4	189
	72	20.0	44					
	79.2	22.0	41					
100KQL/W75-50-18.5/2	52.5	14.6	53	2960	76	18.5	4	218
	75	20.8	50					
	82.5	22.9	46					

尺寸图DIMENSION FIGURE

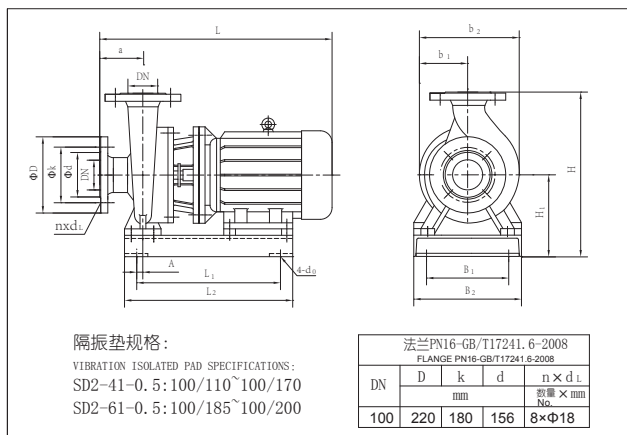

KQW尺寸表DIMENSION TABLE

型号 TYPE	外形尺寸 Figure dimensions				安装尺寸 Installing dimensions								DN
	L	H	b <sub>2</sub>	b <sub>1</sub>	4-φ <sub>0</sub>	a	L <sub>1</sub>	B <sub>1</sub>	L <sub>2</sub>	B <sub>2</sub>	H <sub>1</sub>	A	
100KQW60-16-4/2	670	516	302	150	4-φ15	100	345	180	445	280	251	12.5	100
100KQW70-20-5.5/2	690	516	302	150	4-φ15	100	375	180	475	280	251	12.5	100
100KQW70-26-7.5/2	690	516	302	150	4-φ15	100	375	180	475	280	251	12.5	100
100KQW75-32-11/2	820	517	350	175	4-φ15	100	475	220	575	320	252	12.5	100
100KQW68-38-11/2	845	595	368	180	4-φ15	125	475	260	575	360	305	12.5	100
100KQW72-44-15/2	845	595	368	180	4-φ15	125	475	260	575	360	305	12.5	100
100KQW75-50-18.5/2	875	595	368	180	4-φ15	125	515	260	615	360	305	12.5	100

## 性能曲线CHARACTERISTIC CURVE

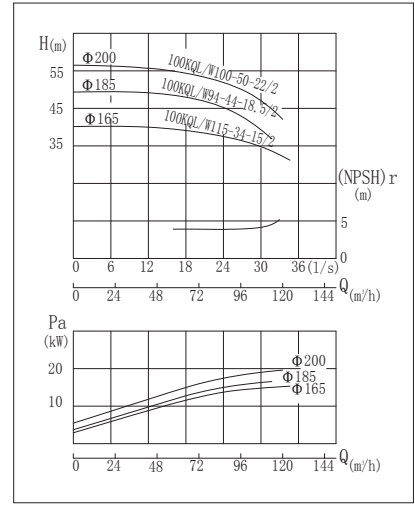
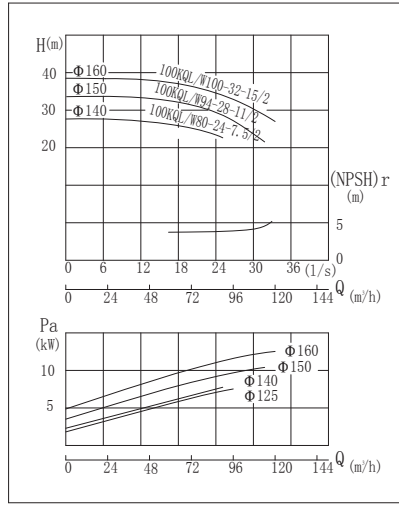
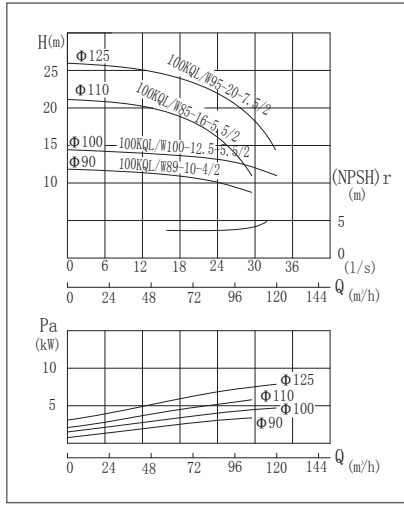

## 尺寸图DIMENSION FIGURE

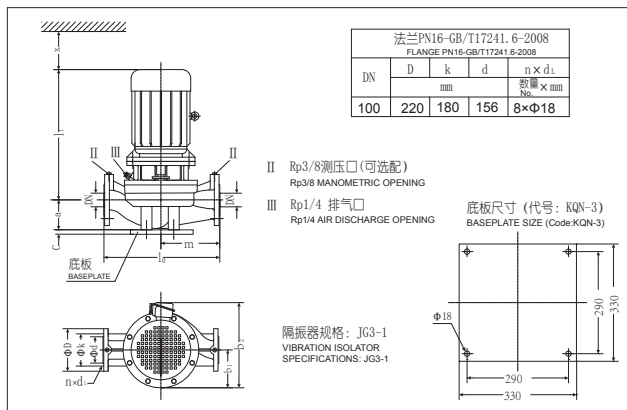

## KQL尺寸表DIMENSION TABLE

型号 TYPE	DN	mm								
		l <sub>0</sub>	m	a	c	l <sub>1</sub>	b <sub>1</sub>	b <sub>2</sub>	x	
100KQL89-10-4/2	100	580	280	180	30	560	125	360	130	
100KQL100-12.5-5.5/2	100	580	280	180	30	580	185	400	130	
100KQL85-16-5.5/2	100	580	280	180	30	580	185	400	130	
100KQL95-20-7.5/2	100	580	280	180	30	580	185	400	130	
100KQL80-24-7.5/2	100	580	280	180	30	580	185	400	130	
100KQL94-28-11/2	100	580	280	180	30	710	225	485	130	
100KQL100-32-15/2	100	580	280	180	30	710	225	485	130	
100KQL115-34-15/2	100	580	280	180	30	710	225	485	130	
100KQL94-44-18.5/2	100	630	310	180	30	750	225	485	130	
100KQL100-50-22/2	100	630	310	180	30	790	250	530	130	
100KQL87-60-30/2	100	630	310	180	30	840	270	575	130	
100KQL94-70-30/2	100	630	310	180	30	840	270	575	130	
100KQL100-80-37/2	100	630	310	180	30	840	270	575	130	



性能曲线CHARACTERISTIC CURVE

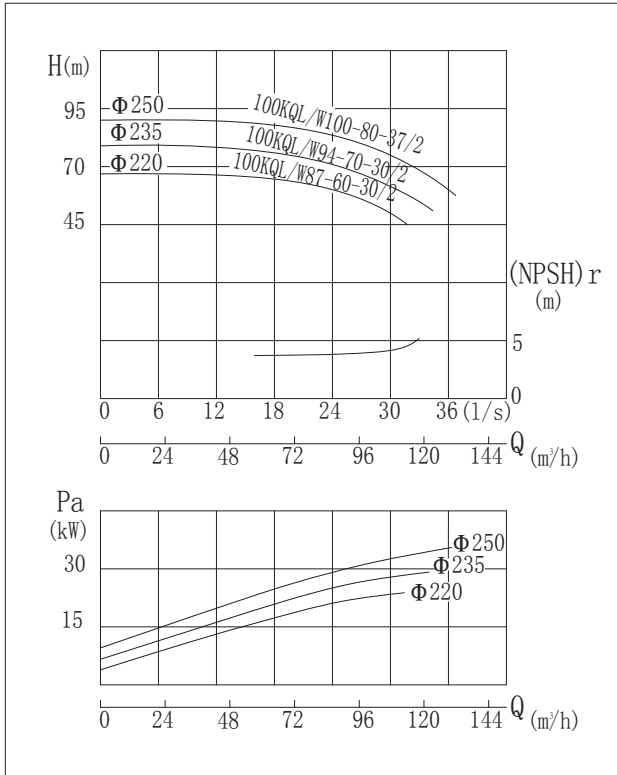

参数表PERFORMANCE DATA

型号 TYPE	流量 Capacity		扬程 Head (m)	转速 Speed (r/min)	效率 Efficiency (%)	电机 功率 Power (kW)	必需汽蚀 余量 (NPSH)r (m)	重量 Weight (kg)
	(m³/h)	(l/s)						
100KQL/W89-10-4/2	62.6	17.4	12	2960	77	4	4.5	94
	89	24.7	10					
	107	29.7	8.8					
100KQL/W100-12.5-5.5/2	70	19.4	13.6	2960	78	5.5	4.5	113
	100	27.8	12.5					
	120	33.3	8					
100KQL/W85-16-5.5/2	59.5	16.5	16.8	2960	79	5.5	4.5	115
	85	23.6	16					
	93.5	26.0	14.4					
100KQL/W95-20-7.5/2	66.5	18.5	22.8	2960	80	7.5	4.5	132
	95	26.4	20					
	104.5	29.0	18.5					
100KQL/W80-24-7.5/2	56	15.6	25.2	2960	79	7.5	4.5	135
	80	22.2	24					
	88	24.4	22.4					
100KQL/W94-28-11/2	65.4	18.2	32	2960	78	11	4.5	190
	93.5	26.0	28					
	112	31.1	23					
100KQL/W100-32-15/2	70	19.4	35	2960	79	15	4.5	195
	100	27.8	32					
	120	33.3	27					
100KQL/W115-34-15/2	80.5	22.4	38.5	2960	79	15	4.5	190
	115	31.9	34					
	126.5	35.1	32					
100KQL/W94-44-18.5/2	65.4	18.2	47.5	2960	78	18.5	4	218
	93.5	26.0	44					
	112	31.1	37					
100KQL/W100-50-22/2	70	19.4	54	2960	79	22	4	250
	100	27.8	50					
	120	33.3	42					
100KQL/W87-60-30/2	61	16.9	65	2960	73	30	4	346
	87	24.2	60					
	104	28.9	50					
100KQL/W94-70-30/2	65.4	18.2	76	2960	74	30	4	347
	93.5	26.0	70					
	112	31.1	59					
100KQL/W100-80-37/2	70	19.4	87	2960	75	37	4	370
	100	27.8	80					
	120	33.3	68					

尺寸图DIMENSION FIGURE

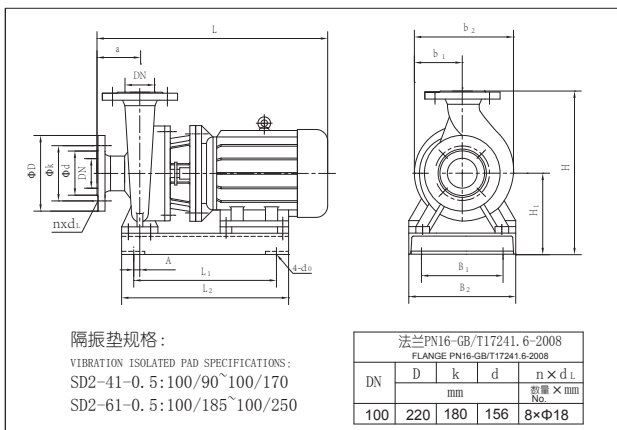

KQW尺寸表DIMENSION TABLE

型号 TYPE	外形尺寸 Figure dimensions				安装尺寸 Installing dimensions								DN
	L	H	b <sub>2</sub>	b <sub>1</sub>	4-φ <sub>0</sub>	a	L <sub>1</sub>	B <sub>1</sub>	L <sub>2</sub>	B <sub>2</sub>	H <sub>1</sub>	A	
100KQW89-10-4/2	650	516	302	150	4-φ15	100	345	180	445	280	251	12.5	100
100KQW100-12.5-5.5/2	690	516	302	150	4-φ15	100	375	180	475	280	251	12.5	100
100KQW85-16-5.5/2	690	516	302	150	4-φ15	100	375	180	475	280	251	12.5	100
100KQW95-20-7.5/2	690	516	302	150	4-φ15	100	375	180	475	280	251	12.5	100
100KQW80-24-7.5/2	690	516	302	150	4-φ15	100	375	180	475	280	251	12.5	100
100KQW94-28-11/2	820	517	350	175	4-φ15	100	475	220	575	320	252	12.5	100
100KQW100-32-15/2	820	517	350	175	4-φ15	100	475	220	575	320	252	12.5	100
100KQW115-34-15/2	820	517	350	175	4-φ15	100	475	220	575	320	252	12.5	100
100KQW94-44-18.5/2	875	595	368	180	4-φ15	125	515	260	615	360	305	12.5	100
100KQW100-50-22/2	915	595	380	190	4-φ15	125	520	260	620	360	305	12.5	100
100KQW87-60-30/2	975	594	420	210	4-φ15	125	610	300	710	400	304	12.5	100
100KQW94-70-30/2	975	594	420	210	4-φ15	125	610	300	710	400	304	12.5	100
100KQW100-80-37/2	975	594	420	210	4-φ15	125	610	300	710	400	304	12.5	100

## 性能曲线CHARACTERISTIC CURVE

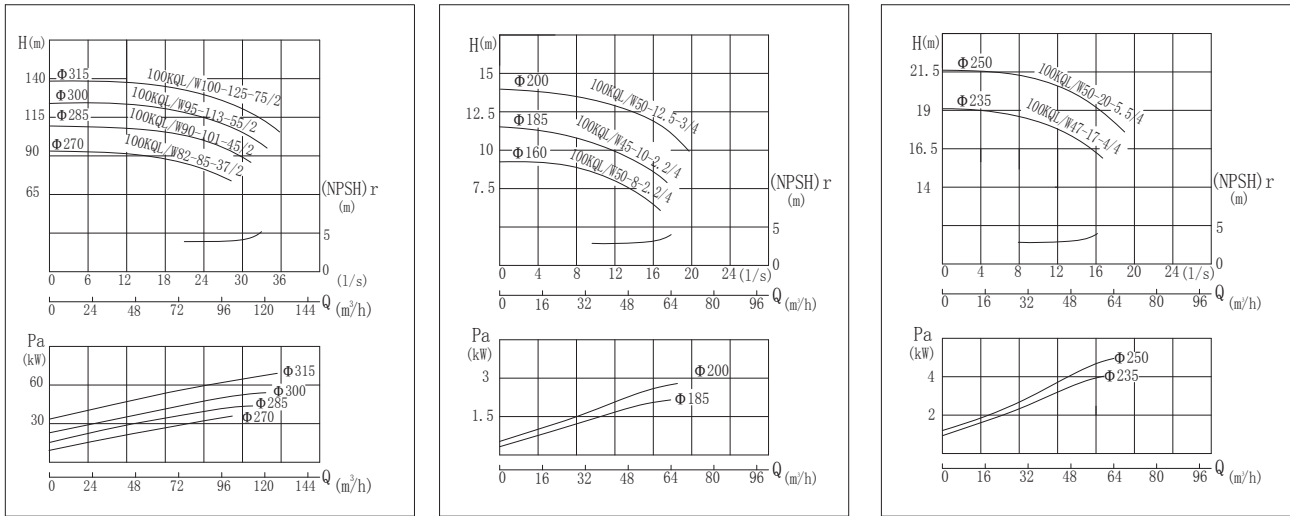

## 尺寸图DIMENSION FIGURE

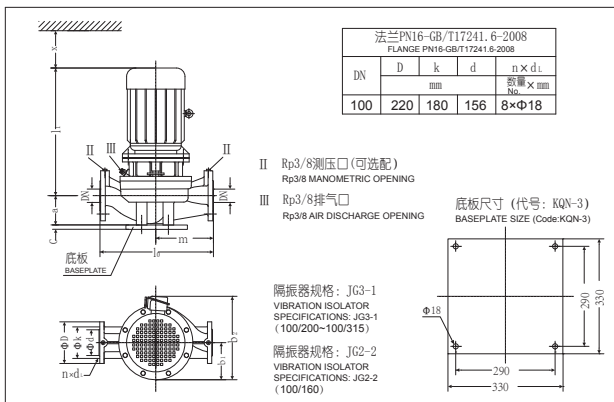

## KQL尺寸表DIMENSION TABLE

型号 TYPE	DN	l <sub>0</sub>	m	a	c	l <sub>1</sub>	b <sub>1</sub>	b <sub>2</sub>	x
		mm							
100KQL82-85-37/2	100	640	315	175	30	860	210	525	130
100KQL90-101-45/2	100	640	315	175	30	895	240	585	130
100KQL95-113-55/2	100	640	315	175	30	955	275	660	130
100KQL100-125-75/2	100	640	315	175	30	1035	295	705	130
100KQL50-8-2.2/4	100	580	280	180	30	525	130	310	130
100KQL45-10-2.2/4	100	630	310	180	30	535	170	350	130
100KQL50-12.5-3/4	100	630	310	180	30	535	170	360	130
100KQL47-17-4/4	100	630	310	180	30	570	170	360	130
100KQL50-20-5.5/4	100	630	310	180	30	590	170	380	130
100KQL47-28-7.5/4	100	640	315	175	30	659	205	415	130
100KQL50-32-11/4	100	640	315	175	30	739	205	470	130

### 性能曲线CHARACTERISTIC CURVE

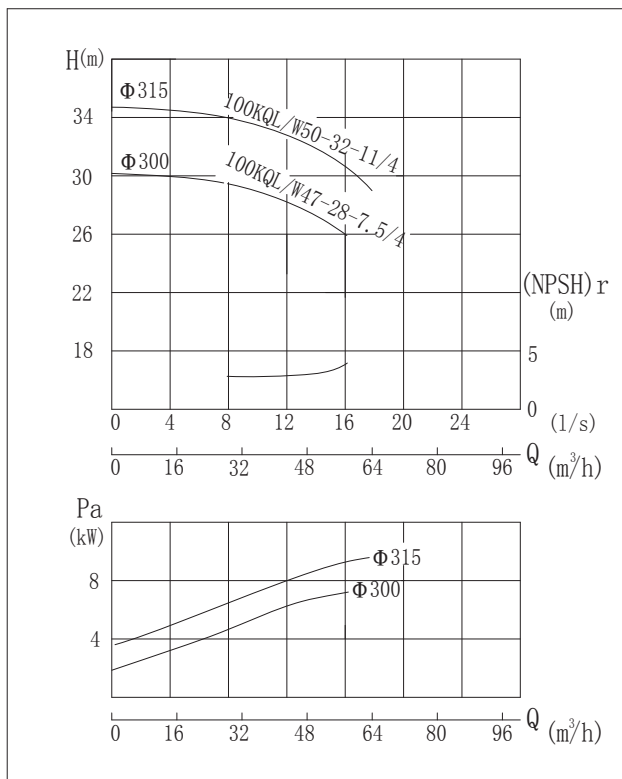

### 参数表PERFORMANCE DATA

型号 TYPE	流量 Capacity		扬程 Head (m)	转速 Speed (r/min)	效率 Efficiency (%)	电机 功率 (kW)	必需汽蚀 余量 (NPSH)r (m)	重量 Weight (kg)
	(m³/h)	(l/s)						
100KQL/W82-85-37/2	58	16.1	88	2960	66	37	4	361
	82	22.8	85					
	98.5	27.3	78					
100KQL/W90-101-45/2	63	17.5	105	2960	67	45	4	475
	90	25	101					
	108	30	94					
100KQL/W95-113-55/2	66	18.3	117	2960	68	55	4	618
	95	26.4	113					
	114	31.7	106					
100KQL/W100-125-75/2	70	19.4	129	2960	69	75	4	760
	100	27.8	125					
	120	33.3	118					
100KQL/W50-8-2.2/4	30	8.33	9.2	1480	77	2.2	3	120
	50	13.89	8					
	60	16.67	6.8					
100KQL/W45-10-2.2/4	26.8	7.44	10.7	1480	70	2.2	3	80
	44.6	12.4	9.9					
	53.5	14.9	9.4					
100KQL/W50-12.5-3/4	30	8.33	13.5	1480	71	3	3	93
	50	13.89	12.5					
	60	16.67	11.8					
100KQL/W47-17-4/4	28	7.78	18.6	1480	70	4	3	115
	46.7	12.97	17.4					
	56	15.56	16.6					
100KQL/W50-20-5.5/4	30	8.33	21.3	1480	71	5.5	3	139
	50	13.89	20					
	60	16.67	19					
100KQL/W47-28-7.5/4	28	7.78	29.6	1480	64	7.5	3	220
	46.7	12.97	27.9					
	56	15.56	26.1					
100KQL/W50-32-11/4	30	8.33	34	1480	65	11	3	236
	50	13.89	32					
	60	16.67	29					

### 尺寸图DIMENSION FIGURE

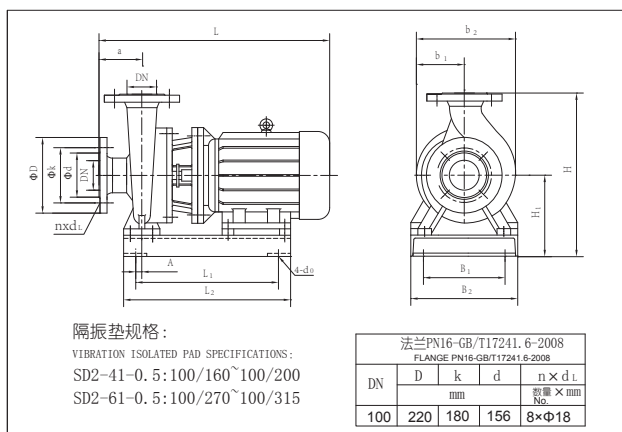

### KQW尺寸表DIMENSION TABLE

型号 TYPE	外形尺寸 Figure dimensions				安装尺寸 Installing dimensions								DN
	L	H	b <sub>2</sub>	b <sub>1</sub>	4-φ <sub>0</sub>	a	L <sub>1</sub>	B <sub>1</sub>	L <sub>2</sub>	B <sub>2</sub>	H <sub>1</sub>	A	
100KQW82-85-37/2	985	644	420	210	4-φ15	125	635	300	735	400	329	30	100
100KQW90-101-45/2	1020	634	470	235	4-φ20	125	665	310	765	440	319	30	100
100KQW95-113-55/2	1080	692	550	275	4-φ20	125	730	370	830	500	377	30	100
100KQW100-125-75/2	1150	696	580	290	4-φ20	125	800	430	900	560	381	30	100
100KQW50-8-2.2/4	615	516	292	140	4-φ15	100	315	180	430	280	251	10	100
100KQW45-10-2.2/4	640	595	355	167	4-φ15	125	315	280	430	360	305	10	100
100KQW50-12.5-3/4	640	595	355	167	4-φ15	125	315	280	430	360	305	10	100
100KQW47-17-4/4	675	595	355	167	4-φ15	125	315	280	440	360	305	10	100
100KQW50-20-5.5/4	705	595	355	167	4-φ15	125	355	280	470	360	305	20	100
100KQW47-28-7.5/4	765	649	397	189	4-φ15	125	400	315	535	400	334	20	100
100KQW50-32-11/4	855	649	397	189	4-φ15	125	450	315	600	400	334	30	100

## 性能曲线CHARACTERISTIC CURVE

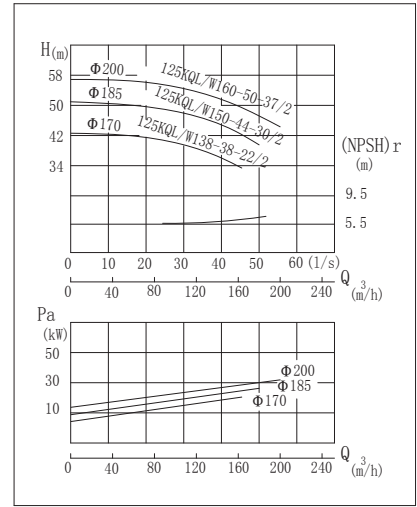
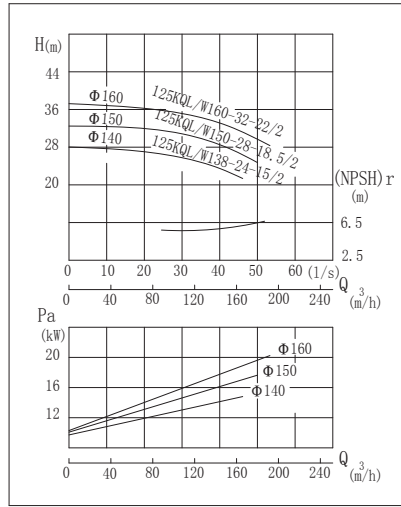
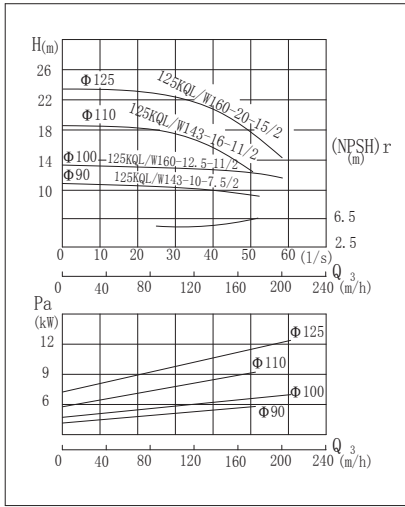

## 尺寸图DIMENSION FIGURE

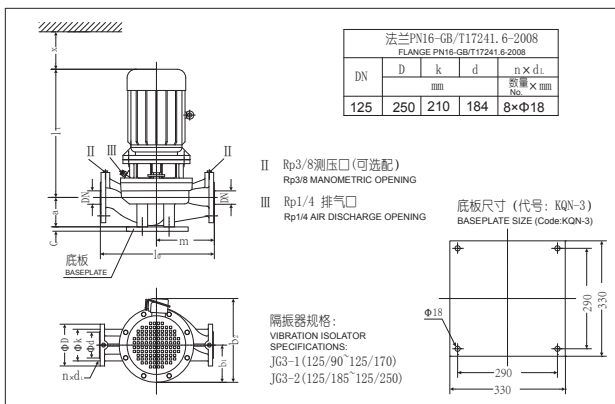

## KQL尺寸表DIMENSION TABLE

型号 TYPE	DN	mm							
		l <sub>0</sub>	m	a	c	l <sub>1</sub>	b <sub>1</sub>	b <sub>2</sub>	x
125KQL143-10-7.5/2	125	645	320	220	30	585	150	360	130
125KQL160-12.5-11/2	125	645	320	220	30	710	175	430	130
125KQL143-16-11/2	125	645	320	220	30	710	225	485	130
125KQL160-20-15/2	125	645	320	220	30	715	225	485	130
125KQL138-24-15/2	125	645	320	220	30	715	225	485	130
125KQL150-28-18.5/2	125	645	320	220	30	747	225	485	130
125KQL160-32-22/2	125	645	320	220	30	789	250	530	130
125KQL138-38-22/2	125	700	350	210	30	792	250	530	140
125KQL150-44-30/2	125	700	350	210	30	860	270	575	140
125KQL160-50-37/2	125	700	350	210	30	860	270	575	140
125KQL138-60-37/2	125	700	350	210	30	860	270	575	140
125KQL150-70-45/2	125	700	350	210	30	895	295	625	140
125KQL160-80-55/2	125	700	350	210	30	955	315	680	140

性能曲线CHARACTERISTIC CURVE

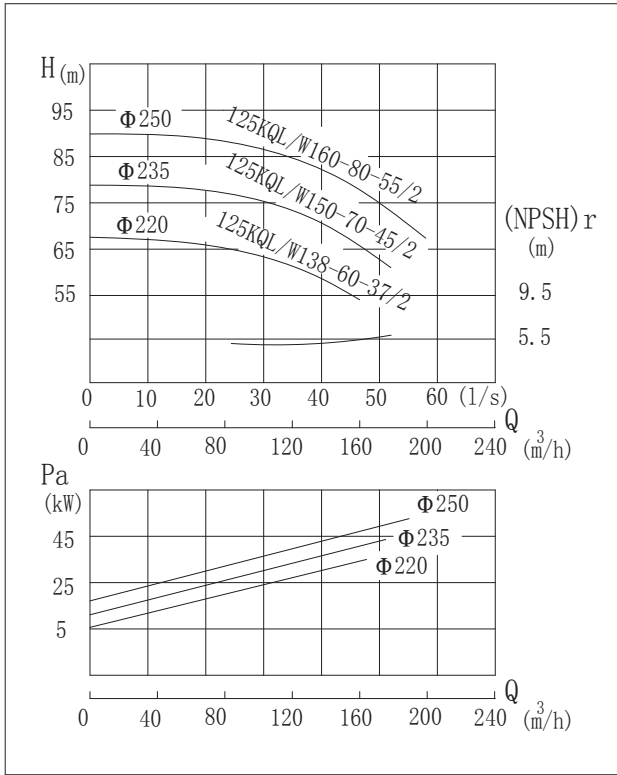

参数表PERFORMANCE DATA

型号 TYPE	流量 Capacity		扬程 Head (m)	转速 Speed (r/min)	效率 Efficiency (%)	电机 功率 Power (kW)	必需汽蚀 余量 (NPSH)r (m)	重量 Weight (kg)
	(m³/h)	(l/s)						
125KQL/W143-10-7.5/2	86	23.9	14	2960	74	7.5	5.5	88
	143	39.7	10					
	172	47.8	7					
125KQL/W160-12.5-11/2	96	26.7	18	2960	75	11	5.5	184
	160	44.4	12.5					
	192	53.3	8					
125KQL/W143-16-11/2	86	23.9	19.2	2960	79	11	5.5	185
	143	39.7	16					
	172	47.8	11.5					
125KQL/W160-20-15/2	96	26.7	25	2960	81	15	5.5	240
	160	44.4	20					
	192	53.3	17					
125KQL/W138-24-15/2	83	21.7	26	2960	80	15	5.5	241
	138	38.3	24					
	166	46.1	21					
125KQL/W150-28-18.5/2	90	25	31.5	2960	81	18.5	5.5	217
	150	41.7	28					
	180	50	24.5					
125KQL/W160-32-22/2	96	26.7	36	2960	82	22	5.5	258
	160	44.4	32					
	192	53.3	28					
125KQL/W138-38-22/2	83	21.7	41.3	2960	80	22	5.5	273
	138	38.3	37.5					
	166	46.1	34.5					
125KQL/W150-44-30/2	90	25	48.4	2960	81	30	5.5	366
	150	41.7	44					
	180	50	40.5					
125KQL/W160-50-37/2	96	26.7	55	2960	82	37	5.5	397
	160	44.4	50					
	192	53.3	46					
125KQL/W138-60-37/2	83	21.7	66	2960	78	37	5	405
	138	38.3	60					
	166	46.1	55					
125KQL/W150-70-45/2	90	25	76	2960	79	45	5	457
	150	41.7	70					
	180	50	64					
125KQL/W160-80-55/2	96	26.7	87	2960	80	55	5	575
	160	44.4	80					
	192	53.3	73					

尺寸图DIMENSION FIGURE

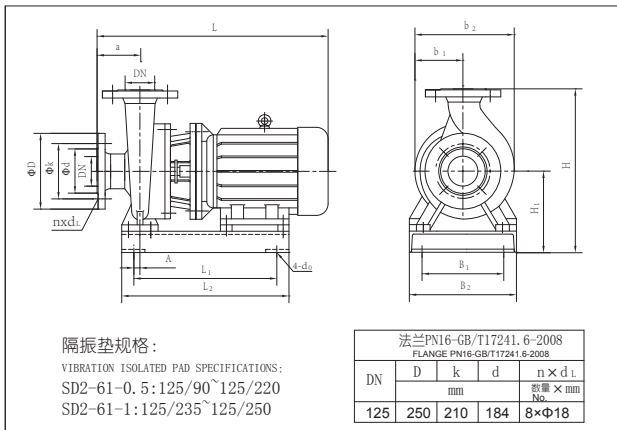

KQW尺寸表DIMENSION TABLE

型号 TYPE	外形尺寸 Figure dimensions				安装尺寸 Installing dimensions								DN
	L	H	b <sub>2</sub>	b <sub>1</sub>	4-φ <sub>d0</sub>	a	L <sub>1</sub>	B <sub>1</sub>	L <sub>2</sub>	B <sub>2</sub>	H <sub>1</sub>	A	
125KQW143-10-7.5/2	710	567	355	175	4-φ15	125	385	220	485	320	277	30	125
125KQW160-12.5-11/2	840	567	355	175	4-φ15	125	485	220	585	320	277	30	125
125KQW143-16-11/2	840	567	355	175	4-φ15	125	485	220	585	320	277	30	125
125KQW160-20-15/2	840	567	355	175	4-φ15	125	485	220	585	320	277	30	125
125KQW138-24-15/2	840	567	355	175	4-φ15	125	485	220	585	320	277	30	125
125KQW150-28-18.5/2	870	567	355	175	4-φ15	125	530	220	630	320	277	30	125
125KQW160-32-22/2	910	575	380	190	4-φ15	125	535	260	635	360	285	30	125
125KQW138-38-22/2	925	625	393	190	4-φ15	125	550	260	650	360	305	30	125
125KQW150-44-30/2	985	624	420	210	4-φ15	125	635	300	735	400	304	30	125
125KQW160-50-37/2	985	624	420	210	4-φ15	125	635	300	735	400	304	30	125
125KQW138-60-37/2	985	624	420	210	4-φ15	125	635	300	735	400	304	30	125
125KQW150-70-45/2	1020	639	470	235	4-φ20	125	665	310	765	440	319	30	125
125KQW160-80-55/2	1080	697	550	275	4-φ20	125	730	370	830	500	377	30	125

## 性能曲线CHARACTERISTIC CURVE

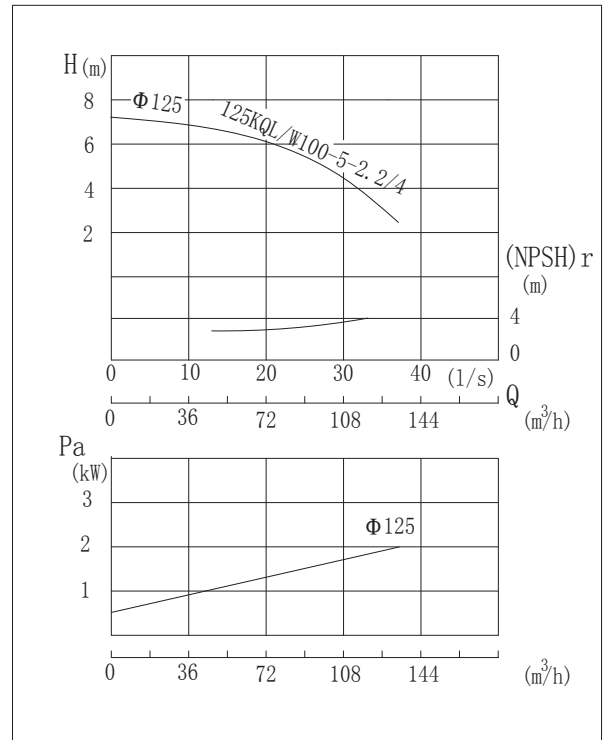
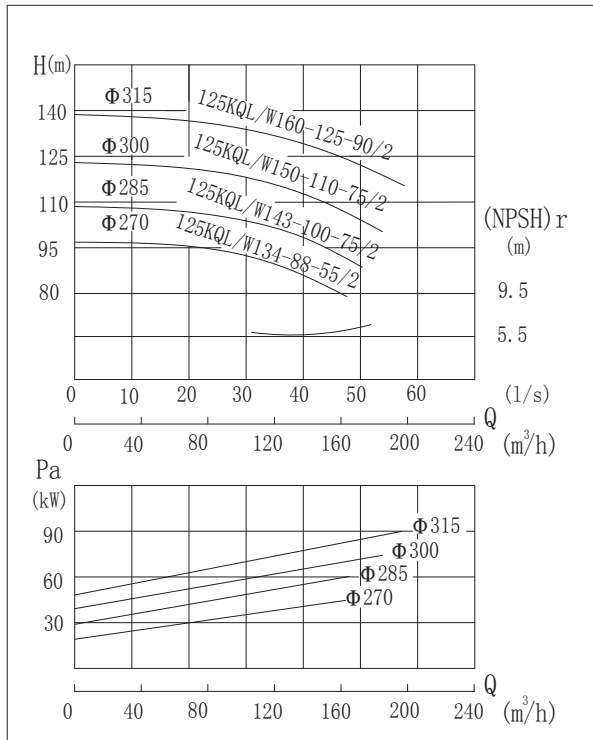

## 尺寸图DIMENSION FIGURE

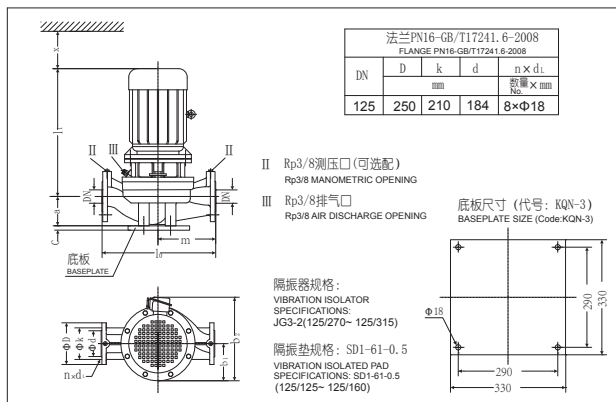

## KQL尺寸表DIMENSION TABLE

型号 TYPE	DN	$l_0$	$m$	$a$	$c$	$l_1$	$b_1$	$b_2$	$x$
		mm							
125KQL134-88-55/2	125	650	320	175	30	955	275	660	140
125KQL143-100-75/2	125	650	320	175	30	1021	295	705	140
125KQL150-110-75/2	125	650	320	175	30	1021	295	705	140
125KQL160-125-90/2	125	650	320	175	30	1075	295	705	140
125KQL100-5-2.2/4	125	610	280	210	30	512	145	335	130
125KQL87-6-3/4	125	610	280	210	30	512	145	335	130
125KQL100-8-4/4	125	610	280	210	30	547	145	335	130



性能曲线CHARACTERISTIC CURVE

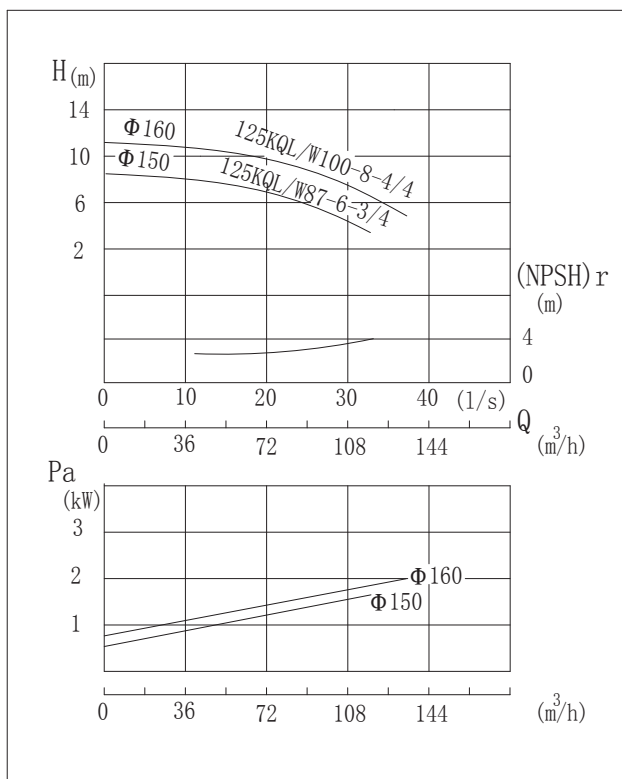

参数表PERFORMANCE DATA

型号 TYPE	流量 Capacity		扬程 Head (m)	转速 Speed (r/min)	效率 Efficiency (%)	电机 功率 Power (kW)	必需汽蚀 余量 (NPSH)r (m)	重量 Weight (kg)
	<sup>3</sup> (m/h)	(l/s)						
125KQL/W134-88-55/2	80.5	22.4	96	2960	73	55	5	512
	134	37.2	88					
	161	44.7	81					
125KQL/W143-100-75/2	86	23.9	108	2960	74	75	5	766
	143	39.7	100					
	172	47.8	94					
125KQL/W150-110-75/2	90	25	115	2960	75	75	5	693
	150	41.7	110					
	180	50	102					
125KQL/W160-125-90/2	96	26.7	132	2960	76	90	5	808
	160	44.4	125					
	192	53.3	118					
125KQL/W100-5-2.2/4	60	16.67	6.5	1480	78	2.2	3	110
	100	27.8	5					
	200	33.33	4					
125KQL/W87-6-3/4	52	14.5	7.5	1480	79	3	3	113
	87	24.2	6.3					
	104	28.9	5.1					
125KQL/W100-8-4/4	60	16.67	9.4	1480	80	4	3	113
	100	27.8	8					
	120	33.33	6.7					

尺寸图DIMENSION FIGURE

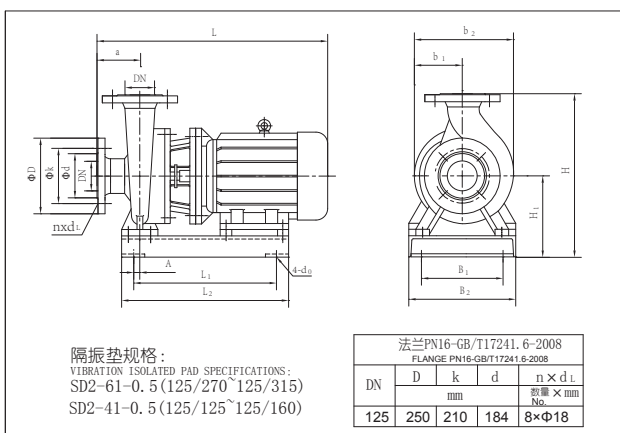

KQW尺寸表DIMENSION TABLE

型号 TYPE	外形尺寸 Figure dimensions				安装尺寸 Installing dimensions								DN
	L	H	b <sub>2</sub>	b <sub>1</sub>	4-φ <sub>d0</sub>	a	L <sub>1</sub>	B <sub>1</sub>	L <sub>2</sub>	B <sub>2</sub>	H <sub>1</sub>	A	
125KQW134-88-55/2	1095	667	550	275	4-φ20	125	730	370	830	500	347	30	125
125KQW143-100-75/2	1165	701	580	290	4-φ20	125	800	430	900	560	381	30	125
125KQW150-110-75/2	1165	701	580	290	4-φ20	125	800	430	900	560	381	30	125
125KQW160-125-90/2	1215	701	580	290	4-φ20	125	850	430	950	560	381	30	125
125KQW100-5-2.2/4	637	557	350	160	4-φ15	125	340	220	440	320	277	30	125
125KQW87-6-3/4	637	557	350	160	4-φ15	125	340	220	440	320	277	30	125
125KQW100-8-4/4	672	557	350	160	4-φ15	125	350	220	450	320	277	30	125

## 性能曲线CHARACTERISTIC CURVE

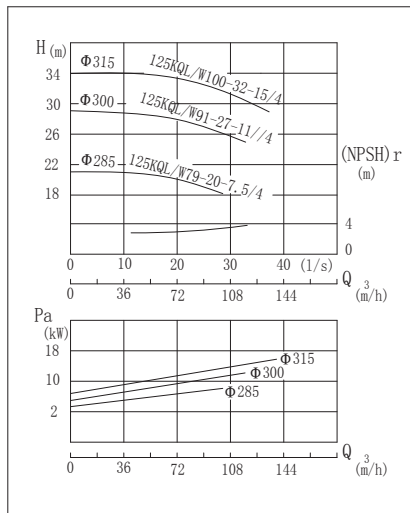
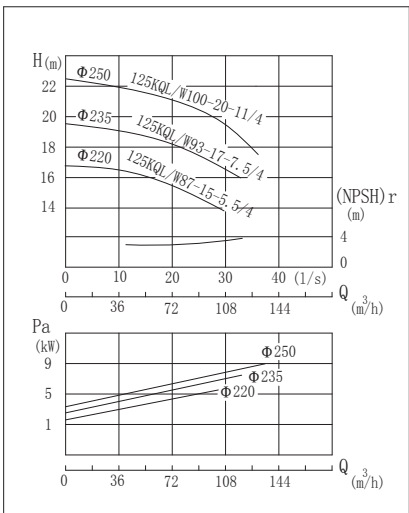
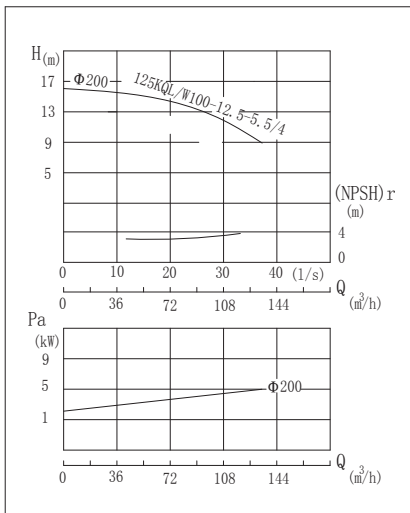

## 尺寸图DIMENSION FIGURE

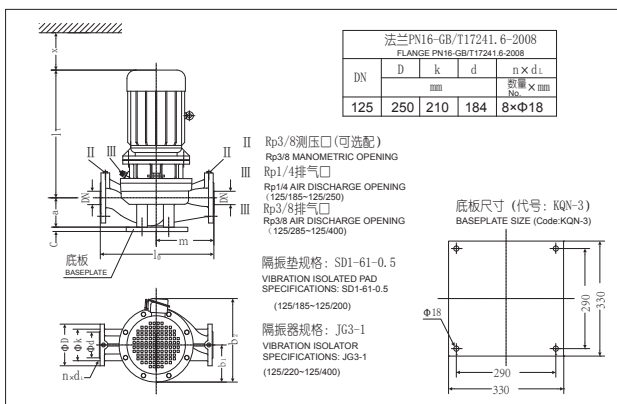

## KQL尺寸表DIMENSION TABLE

型号 TYPE	DN	l <sub>0</sub>	m	a	c	l <sub>1</sub>	b <sub>1</sub>	b <sub>2</sub>	x
		mm							
125KQL100-12.5-5.5/4	125	700	335	200	30	588	185	395	130
125KQL87-15-5.5/4	125	700	335	200	30	588	185	395	130
125KQL93-17-7.5/4	125	700	335	200	30	638	185	395	130
125KQL120-16-7.5/4	125	700	335	200	30	638	185	395	130
125KQL100-20-11/4	125	700	335	200	30	718	225	485	130
125KQL79-20-7.5/4	125	785	385	210	30	638	240	515	130
125KQL91-27-11/4	125	785	385	210	30	732	240	515	130
125KQL100-32-15/4	125	785	385	210	30	762	240	515	130
125KQL87-38-18.5/4	125	785	385	210	30	802	250	530	130
125KQL94-44-22/4	125	785	385	210	30	852	250	530	130
125KQL100-50-30/4	125	785	385	210	30	862	270	575	130

性能曲线CHARACTERISTIC CURVE

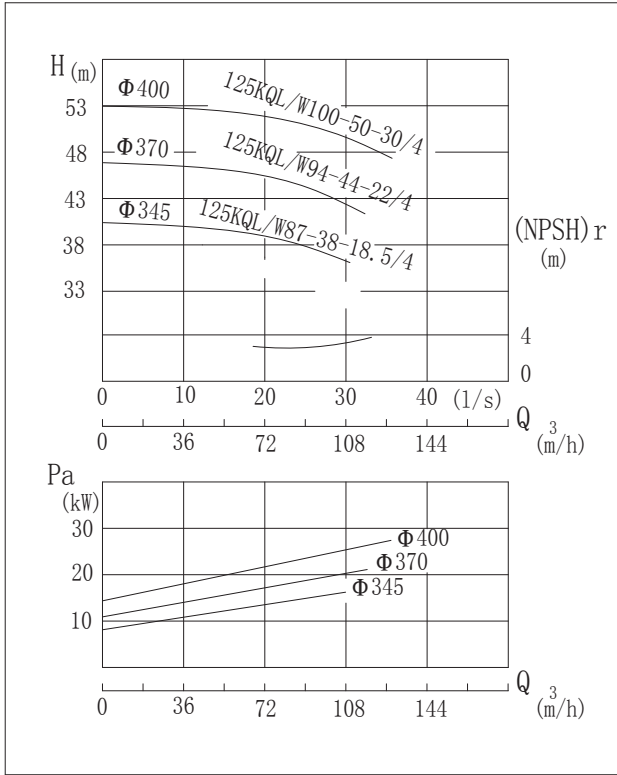

参数表PERFORMANCE DATA

型号 TYPE	流量 Capacity		扬程 Head (m)	转速 Speed (r/min)	效率 Efficiency (%)	电机 功率 Power (kW)	必需汽蚀 余量 (NPSH)r (m)	重量 Weight (kg)
	(m³/h)	(l/s)						
125KQL/W100-12.5-5.5/4	60	16.67	14	1480	78	5.5	3	185
	100	27.8	12.5					
	120	33.33	11					
125KQL/W87-15-5.5/4	52	14.5	16.4	1480	76	5.5	3	158
	87	24.2	15					
	104	28.9	14					
125KQL/W93-17-7.5/4	56	15.6	19	1480	77	7.5	3	209
	93	25.8	17.4					
	112	31.1	15.5					
125KQL/W120-16-7.5/4	84	23.3	18.5	1480	78	7.5	3	163
	120	33.3	16					
	132	36.7	14.4					
125KQL/W100-20-11/4	60	16.7	21.5	1480	78	11	3	280
	100	27.8	20					
	120	33.3	18					
125KQL/W79-20-7.5/4	47	13.1	21	1480	72	7.5	3	230
	79	21.9	20					
	95	26.4	18					
125KQL/W91-27-11/4	55	15.3	29	1480	73	11	3	276
	91	25.3	27					
	110	30.6	22					
125KQL/W100-32-15/4	60	16.7	35	1480	74	15	3	305
	100	27.8	32					
	120	33.3	27					
125KQL/W87-38-18.5/4	52.3	14.5	39	1480	67	18.5	3	311
	87	24.2	38					
	105	29.2	37					
125KQL/W94-44-22/4	56.4	15.7	46	1480	68	22	3	368
	94	26.1	44					
	113	31.4	41					
125KQL/W100-50-30/4	60	16.7	52	1480	69	30	3	450
	100	27.8	50					
	120	33.3	47					

尺寸图DIMENSION FIGURE

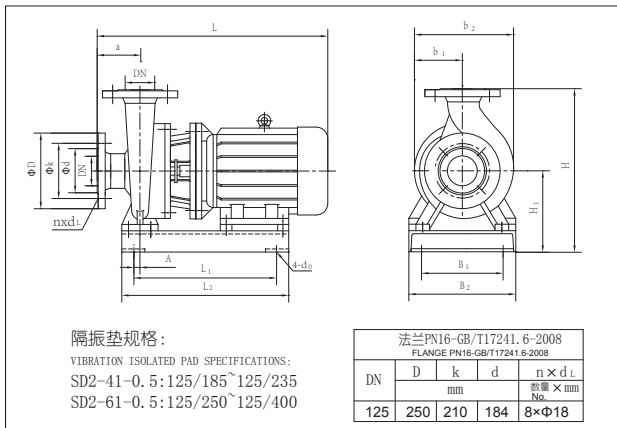

KQW尺寸表DIMENSION TABLE

型号 TYPE	外形尺寸 Figure dimensions				安装尺寸 Installing dimensions								DN
	L	H	b <sub>2</sub>	b <sub>1</sub>	4-φ <sub>0</sub>	a	L <sub>1</sub>	B <sub>1</sub>	L <sub>2</sub>	B <sub>2</sub>	H <sub>1</sub>	A	
125KQW100-12.5-5.5/4	702	669	412	200	4-φ15	125	390	300	490	400	334	30	125
125KQW87-15-5.5/4	702	669	412	200	4-φ15	125	390	300	490	400	334	30	125
125KQW93-17-7.5/4	752	669	412	200	4-φ15	125	425	300	525	400	334	30	125
125KQW120-16-7.5/4	752	669	412	200	4-φ15	125	425	300	525	400	334	30	125
125KQW100-20-11/4	842	669	412	200	4-φ15	125	485	300	585	400	334	30	125
125KQW79-20-7.5/4	767	767	518	250	4-φ20	125	460	370	560	500	382	50	125
125KQW91-27-11/4	857	767	518	250	4-φ20	125	520	370	620	500	382	50	125
125KQW100-32-15/4	887	767	518	250	4-φ20	125	565	370	665	500	382	50	125
125KQW87-38-18.5/4	927	767	518	250	4-φ20	125	570	370	670	500	382	50	125
125KQW94-44-22/4	977	767	518	250	4-φ20	125	610	370	710	500	382	50	125
125KQW100-50-30/4	987	762	518	250	4-φ20	125	660	370	760	500	377	50	125

## 性能曲线CHARACTERISTIC CURVE

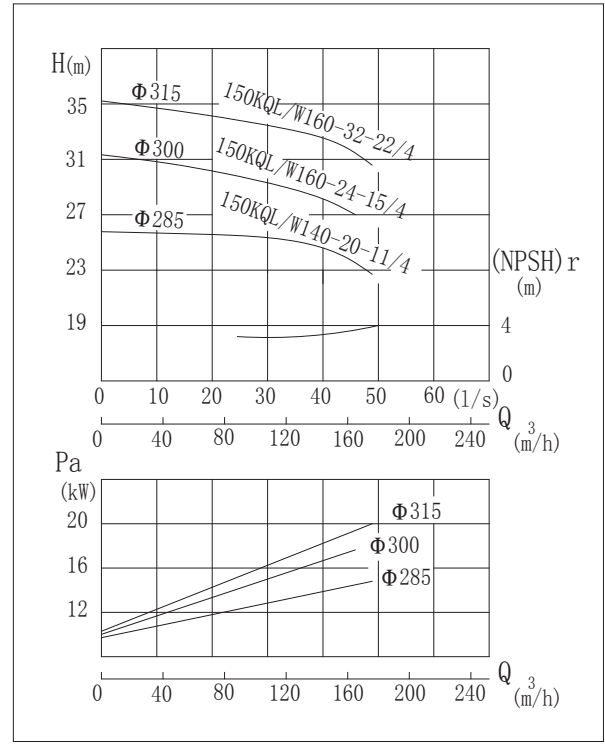
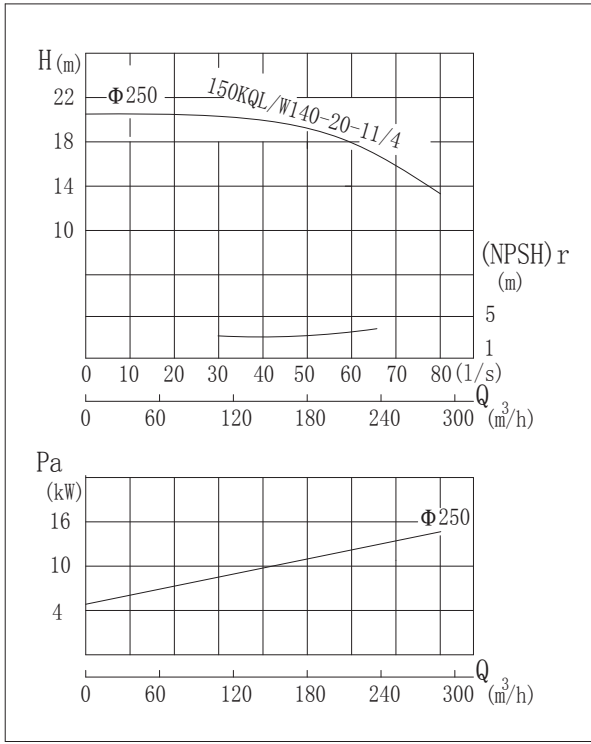

## 尺寸图DIMENSION FIGURE

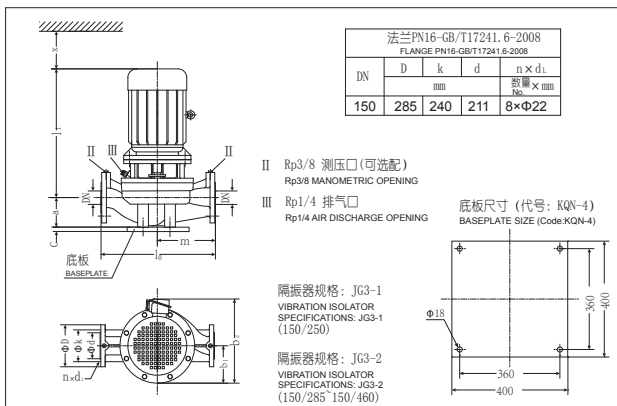

## KQL尺寸表DIMENSION TABLE

型号 TYPE	DN	l <sub>0</sub>	m	a	c	l <sub>1</sub>	b <sub>1</sub>	b <sub>2</sub>	x
	mm								
150KQL140-20-11/4	150	880	430	265	37	725	225	485	150
150KQL160-24-15/4	150	880	430	274	37	758	250	530	155
150KQL150-28-18.5/4	150	880	430	274	37	795	250	530	155
150KQL160-32-22/4	150	880	430	274	37	845	250	530	155
150KQL138-38-22/4	150	880	480	280	37	845	250	530	155
150KQL150-44-30/4	150	970	480	280	37	845	270	575	155
150KQL160-50-37/4	150	970	480	280	37	859	295	625	155

### 性能曲线CHARACTERISTIC CURVE

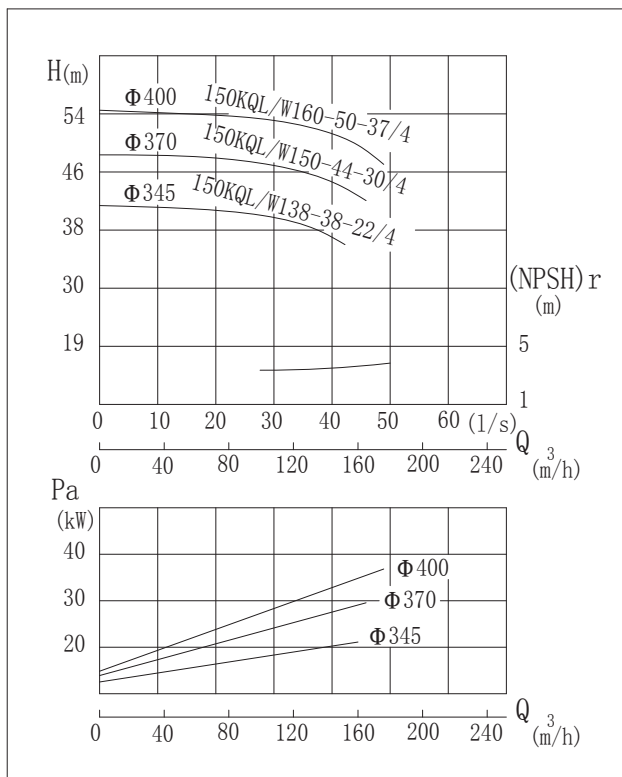

### 参数表PERFORMANCE DATA

型号 TYPE	流量 Capacity		扬程 Head (m)	转速 Speed (r/min)	效率 Efficiency (%)	电机 功率 Power (kW)	必需汽蚀 余量 (NPSH)r (m)	重量 Weight (kg)
	<sup>3</sup> (m/h)	(l/s)						
150KQL/W140-20-11/4	98	27.2	21	1480	79	11	3	260
	140	38.9	20					
	154	42.8	18.4					
150KQL/W160-24-15/4	112	31.1	25.2	1480	76	15	3	300
	160	44.4	24					
	176	48.9	22.5					
150KQL/W150-28-18.5/4	105	29.2	29.4	1480	78	18.5	3	330
	150	41.7	28					
	165	45.8	26.5					
150KQL/W160-32-22/4	112	31.1	33.6	1480	79	22	3	350
	160	44.4	32					
	176	48.9	30					
150KQL/W138-38-22/4	96.6	26.8	39.9	1480	72	22	3.5	352
	138	38.3	38					
	151.8	42.2	36.2					
150KQL/W150-44-30/4	105	29.2	46.2	1480	73	30	3.5	423
	150	41.7	44					
	165	45.8	41.5					
150KQL/W160-50-37/4	112	31.1	52.5	1480	74.7	37	3.5	440
	160	44.4	50					
	176	48.9	47					

### 尺寸图DIMENSION FIGURE

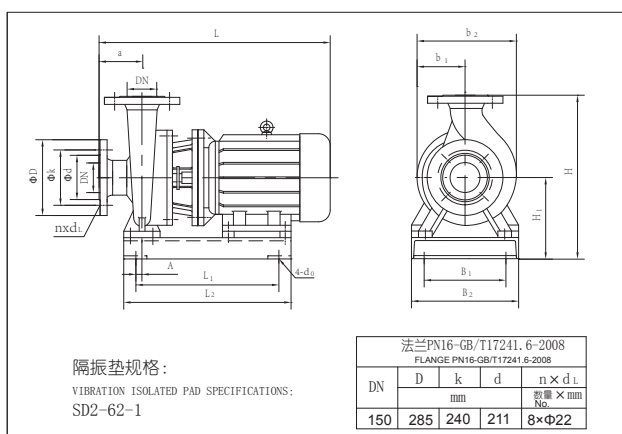

### KQW尺寸表DIMENSION TABLE

型号 TYPE	外形尺寸 Figure dimensions				安装尺寸 Installing dimensions								DN
	L	H	b <sub>2</sub>	b <sub>1</sub>	4-φ <sub>0</sub>	a	L <sub>1</sub>	B <sub>1</sub>	L <sub>2</sub>	B <sub>2</sub>	H <sub>1</sub>	A	
150KQW140-20-11/4	872	759	433	200	4-φ15	140	500	300	600	400	359	30	150
150KQW160-24-15/4	902	759	433	250	4-φ20	140	545	300	645	400	359	30	150
150KQW150-28-18.5/4	945	812	530	250	4-φ20	140	565	370	665	500	382	50	150
150KQW160-32-22/4	995	812	530	250	4-φ20	140	600	370	700	500	382	50	150
150KQW138-38-22/4	995	812	530	250	4-φ20	140	600	370	700	500	382	50	150
150KQW150-44-30/4	996	867	530	250	4-φ20	140	650	370	750	500	417	50	150
150KQW160-50-37/4	1006	862	530	250	4-φ20	140	655	370	762	500	412	50	150

## 性能曲线CHARACTERISTIC CURVE

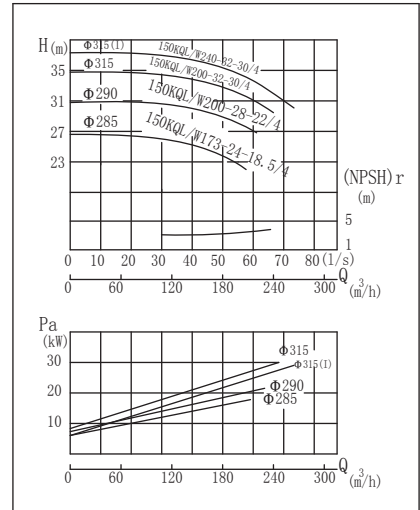
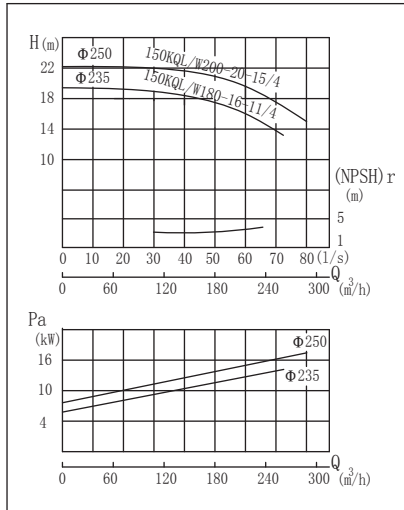
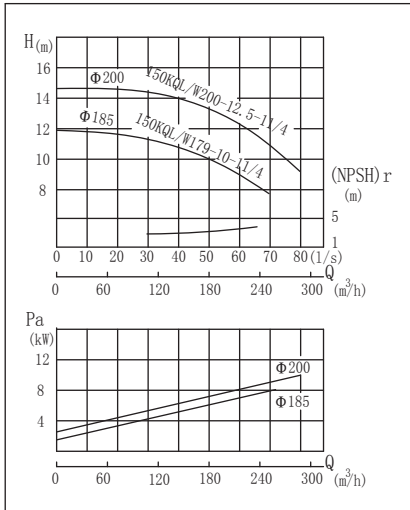

## 尺寸图DIMENSION FIGURE

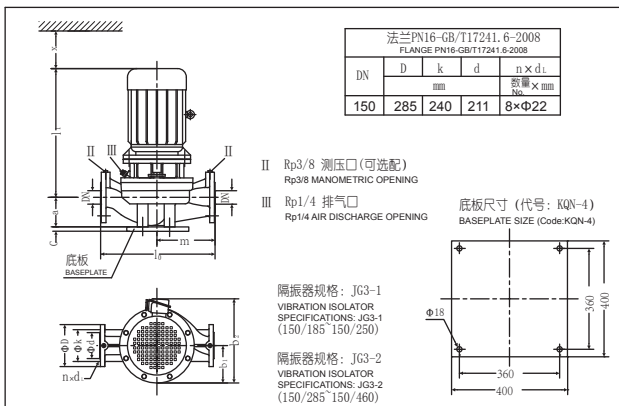

## KQL尺寸表DIMENSION TABLE

型号	DN	l <sub>0</sub>	m	a	c	mm			
						b <sub>1</sub>	b <sub>2</sub>	x	
150KQL179-10-11/4	150	880	430	265	37	725	225	485	150
150KQL200-12.5-11/4	150	880	430	265	37	725	225	485	150
150KQL180-16-11/4	150	880	430	265	37	725	225	485	150
150KQL200-20-15/4	150	880	430	265	37	757	225	485	150
150KQL173-24-18.5/4	150	880	430	274	37	795	250	530	155
150KQL200-28-22/4	150	880	430	274	37	845	250	530	155
150KQL200-32-30/4	150	880	430	274	37	845	270	575	155
150KQL240-32-30/4	150	880	430	274	37	845	270	575	155
150KQL200-38-30/4	150	970	480	280	37	845	270	575	155
150KQL187-44-37/4	150	970	480	280	37	859	295	625	155
150KQL200-50-45/4	150	970	480	280	37	887	295	625	155



### 性能曲线CHARACTERISTIC CURVE

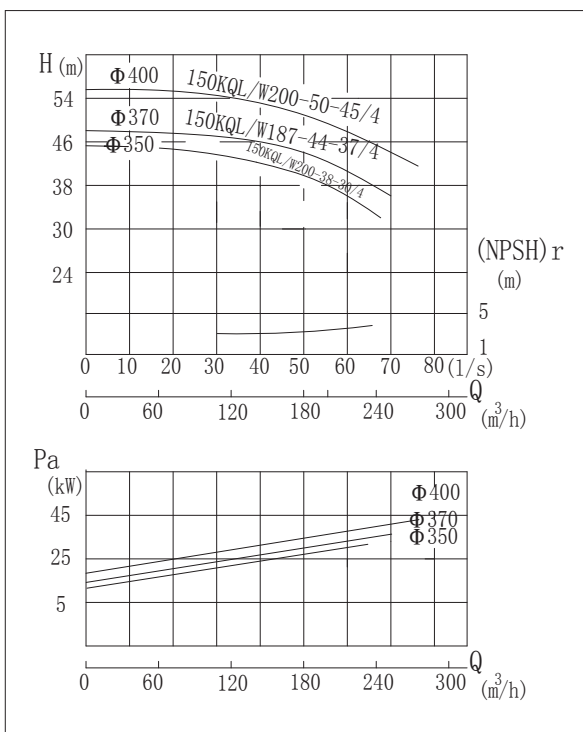

### 参数表PERFORMANCE DATA

型号 TYPE	流量 Capacity		扬程 Head (m)	转速 Speed (r/min)	效率 Efficiency (%)	电机 功率 Power (kW)	必需汽蚀 余量 (NPSH)r (m)	重量 Weight (kg)
	(m³/h)	(l/s)						
150KQL/W179-10-11/4	125	34.7	11.6	1480	80	11	3	260
	179	49.7	10					
	215	59.7	8					
150KQL/W200-12.5-11/4	140	38.9	14.1	1480	82	11	3	265
	200	55.6	12.5					
	240	66.7	10.6					
150KQL/W180-16-11/4	126	35.0	16.8	1480	81.8	11	3	270
	180	50.0	16					
	198	55.0	14.4					
150KQL/W200-20-15/4	140	38.9	21.8	1480	82.8	15	3	278
	200	55.6	20					
	220	61.1	18.5					
150KQL/W173-24-18.5/4	121	33.6	25.8	1480	79	18.5	3.5	324
	173	48.1	24					
	208	57.8	20.7					
150KQL/W200-28-22/4	140	38.9	31	1480	81.7	22	3.5	345
	200	55.6	28					
	220	61.1	25.2					
150KQL/W200-32-30/4	140	38.9	35	1480	81.7	30	3.5	402
	200	55.6	32					
	240	66.7	28					
150KQL/W240-32-30/4	171	47.5	35.2	1480	80	30	4	430
	240	68.1	32					
	264	75.0	28.8					
150KQL/W200-38-30/4	140	38.9	39.9	1480	77	30	3.5	430
	200	55.6	38					
	210	58.3	36					
150KQL/W187-44-37/4	131	36.4	46.6	1480	76	37	3.5	510
	187	51.9	44					
	225	62.5	39					
150KQL/W200-50-45/4	140	38.9	53	1480	77	45	3.5	531
	200	55.6	50					
	240	66.7	44					

### 尺寸图DIMENSION FIGURE

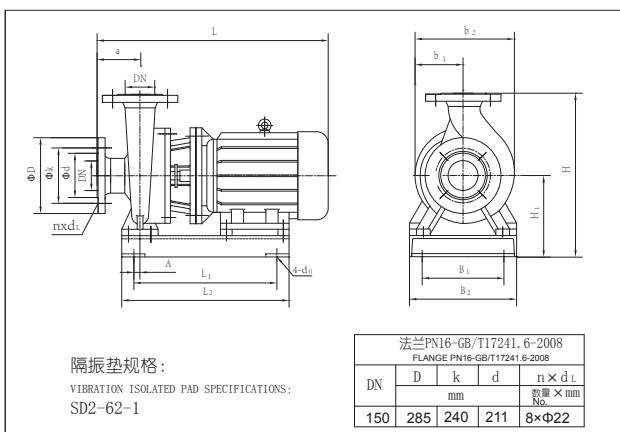

### KQW尺寸表DIMENSION TABLE

型号 TYPE	外形尺寸 Figure dimensions				安装尺寸 Installing dimensions								DN1
	L	H	b <sub>2</sub>	b <sub>1</sub>	4-φ <sub>0</sub>	a	L <sub>1</sub>	B <sub>1</sub>	L <sub>2</sub>	B <sub>2</sub>	H <sub>1</sub>	A	
150KQW179-10-11/4	872	759	433	200	4-φ15	140	500	300	600	400	359	30	150
150KQW200-12.5-11/4	872	759	433	200	4-φ15	140	500	300	600	400	359	30	150
150KQW180-16-11/4	872	759	433	200	4-φ15	140	500	300	600	400	359	30	150
150KQW200-20-15/4	905	759	433	200	4-φ15	140	545	300	645	400	359	30	150
150KQW173-24-18.5/4	945	812	530	250	4-φ20	140	565	370	665	500	382	50	150
150KQW200-28-22/4	995	812	530	250	4-φ20	140	600	370	700	500	382	50	150
150KQW200-32-30/4	995	809	530	250	4-φ20	140	650	370	750	500	379	50	150
150KQW240-32-30/4	996	809	530	250	4-φ20	140	650	370	750	500	379	50	150
150KQW200-38-30/4	995	867	530	250	4-φ20	140	650	370	750	500	417	50	150
150KQW187-44-37/4	1005	864	530	250	4-φ20	140	655	370	762	500	414	50	150
150KQW200-50-45/4	1030	864	530	250	4-φ20	140	680	370	780	500	414	50	150

## 性能曲线CHARACTERISTIC CURVE

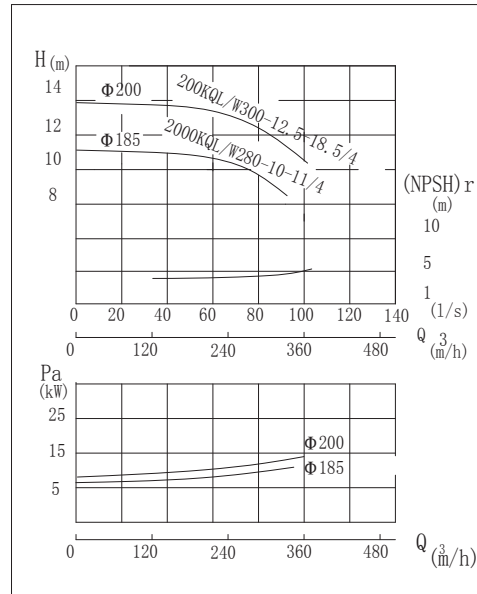
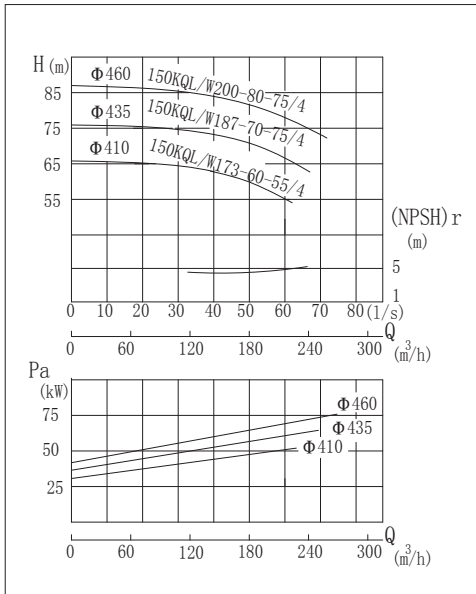

## 尺寸图DIMENSION FIGURE

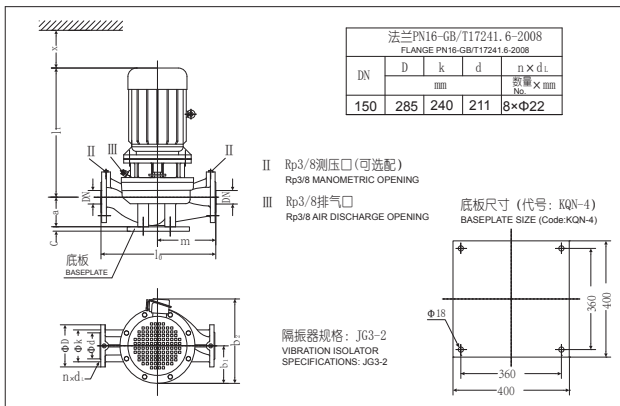

## KQL尺寸表DIMENSION TABLE

型号 TYPE	DN	$l_0$	$m$	$a$	$c$	$l_1$	$b_1$	$b_2$	$x$
		mm							
150KQL173-60-55/4	150	1050	500	280	37	965	315	680	165
150KQL187-70-75/4	150	1050	500	280	37	1030	360	760	165
150KQL200-80-75/4	150	1050	500	280	37	1030	360	760	165

## 尺寸图DIMENSION FIGURE

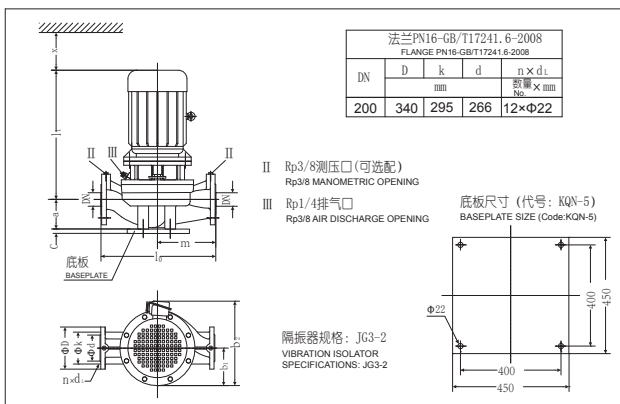

## KQL尺寸表DIMENSION TABLE

型号 TYPE	DN	$l_0$	$m$	$a$	$c$	$l_1$	$b_1$	$b_2$	$x$
		mm							
200KQL280-10-11/4	200	990	480	275	37	751	250	495	150
200KQL300-12.5-15/4	200	990	480	275	37	781	250	495	150
200KQL280-16-18.5/4	200	990	480	275	37	823	250	530	150
200KQL300-20-22/4	200	990	480	275	37	873	250	530	150

性能曲线CHARACTERISTIC CURVE

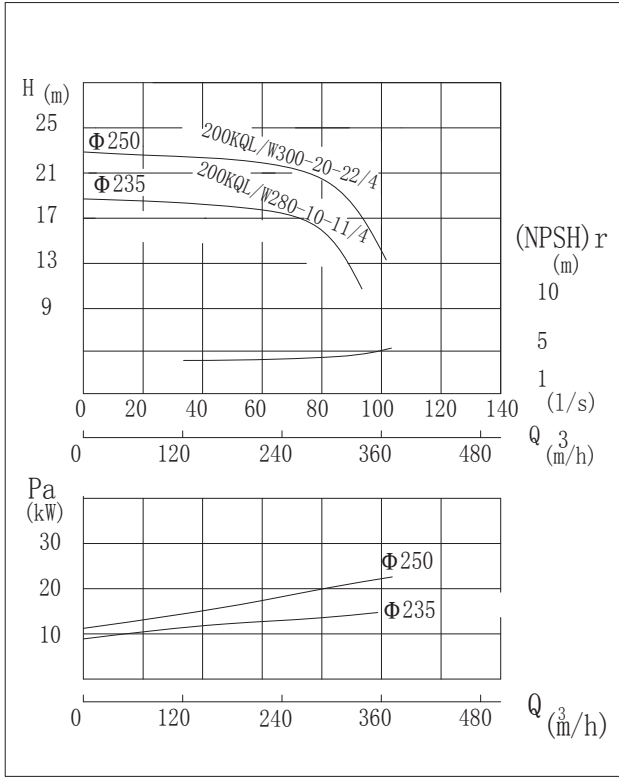

参数表PERFORMANCE DATA

型号 TYPE	流量 Capacity		扬程 Head (m)	转速 Speed (r/min)	效率 Efficiency (%)	电机 功率 (kW)	必需汽蚀 余量 (NPSH)r (m)	重量 Weight (kg)
	(m³/h)	(l/s)						
150KQL/W173-60-55/4	121	33.6	64	1480	69	55	4	703
	173	48.1	60					
	208	57.7	55.5					
150KQW180-70-55/2	126	35.0	75	2960	74	55	6	590
	180	50.0	70					
	216	60.0	64					
150KQL/W187-70-75/4	131	36.4	74	1480	70	75	4	848
	187	51.9	70					
	224	62.3	64					
150KQW200-80-75/2	140	38.9	86	2960	75	75	6	630
	200	55.6	80					
	240	66.7	72					
150KQL/W200-80-75/4	140	38.9	85	1480	71.3	75	4	856
	200	55.6	80					
	240	66.7	75					
200KQL/W280-10-11/4	196	54.4	11.5	1480	82	11	4	326
	280	77.8	10					
	308	85.6	8.6					
200KQL/W300-12.5-15/4	210	58.3	15	1480	83	15	4	345
	300	83.3	12.5					
	330	91.7	11					
200KQL/W280-16-18.5/4	196	54.4	18	1480	82	18.5	4	339
	280	77.8	16					
	336	93.3	13					
200KQL/W300-20-22/4	210	58.3	21.5	1480	84	22	4	425
	300	83.3	20					
	330	91.7	18					

尺寸图DIMENSION FIGURE

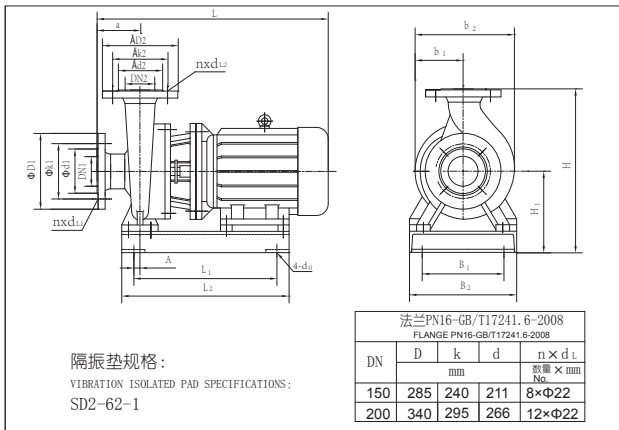

KQW尺寸表DIMENSION TABLE

型号 TYPE	外形尺寸 Figure dimensions				安装尺寸 Installing dimensions										DN1	DN2
	L	H	b <sub>2</sub>	b <sub>1</sub>	4-φ <sub>0</sub>	a	L <sub>1</sub>	B <sub>1</sub>	L <sub>2</sub>	B <sub>2</sub>	H <sub>1</sub>	A				
150KQW173-60-55/4	1145	958	630	305	4-φ20	180	760	430	860	560	458	50	150	150		
150KQW180-70-55/2	1080	958	550	275	4-φ20	125	800	430	900	560	383	30	150	125		
150KQW187-70-75/4	1215	958	630	305	4-φ20	180	830	430	930	560	458	50	150	150		
150KQW200-80-75/2	1150	793	580	290	4-φ20	125	800	430	900	560	383	30	150	125		
150KQW200-80-75/4	1215	958	630	305	4-φ20	180	830	430	930	560	458	50	150	150		
200KQW280-10-11/4	900	862	534	255	4-φ20	160	580	370	680	510	382	50	200	200		
200KQW300-12.5-15/4	930	862	534	255	4-φ20	160	580	370	680	510	382	50	200	200		
200KQW280-16-18.5/4	970	862	534	255	4-φ20	160	580	370	680	510	382	50	200	200		
200KQW300-20-22/4	1020	862	529	250	4-φ20	160	615	370	715	510	382	50	200	200		

## 性能曲线CHARACTERISTIC CURVE

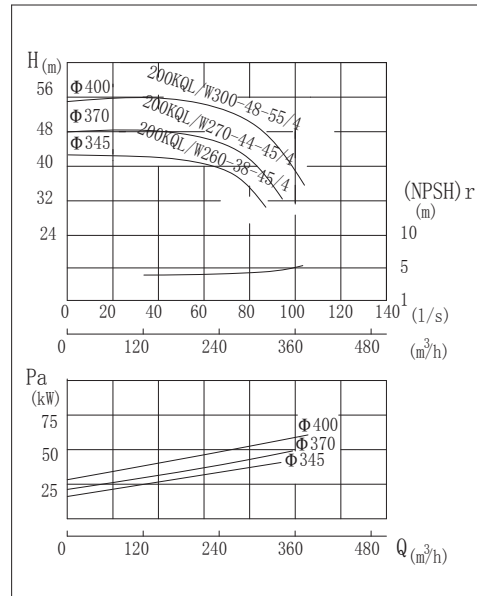
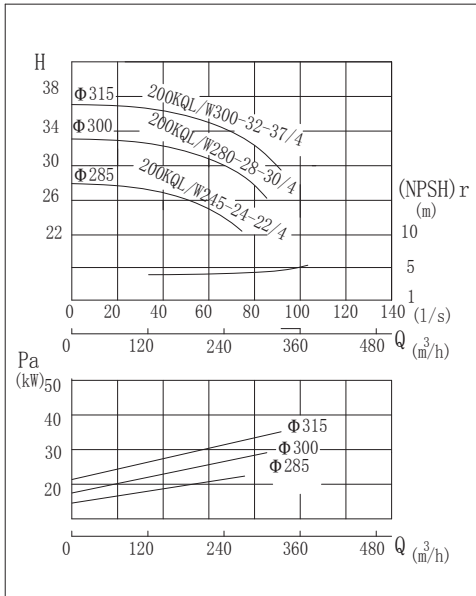

## 尺寸图DIMENSION FIGURE

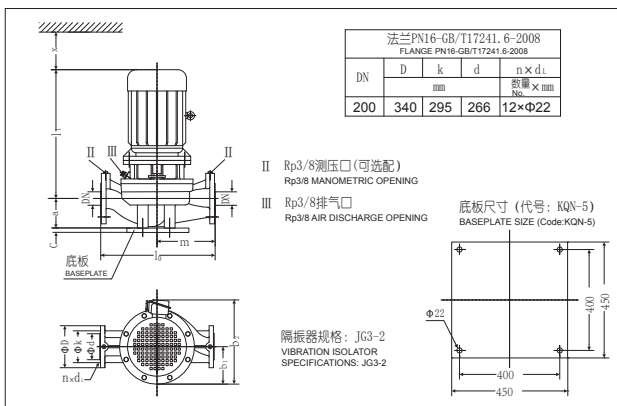

## KQL尺寸表DIMENSION TABLE

型号 TYPE	DN	l <sub>0</sub>	m	a	c	l <sub>1</sub>	b <sub>1</sub>	b <sub>2</sub>	x
		mm							
200KQL245-24-22/4	200	1000	500	295	37	876	250	540	155
200KQL280-28-30/4	200	1000	500	295	37	876	270	610	155
200KQL300-32-37/4	200	1000	500	295	37	886	295	625	155
200KQL260-38-45/4	200	1070	535	280	37	914	295	625	155
200KQL270-44-45/4	200	1070	535	280	37	915	315	680	155
200KQL300-48-55/4	200	1070	535	280	37	976	360	760	155
200KQL262-60-75/4	200	1170	560	320	37	1035	360	760	165
200KQL280-70-90/4	200	1170	560	320	37	1096	360	760	165
200KQL300-80-110/4	200	1170	560	320	37	1350	450	980	165

性能曲线CHARACTERISTIC CURVE

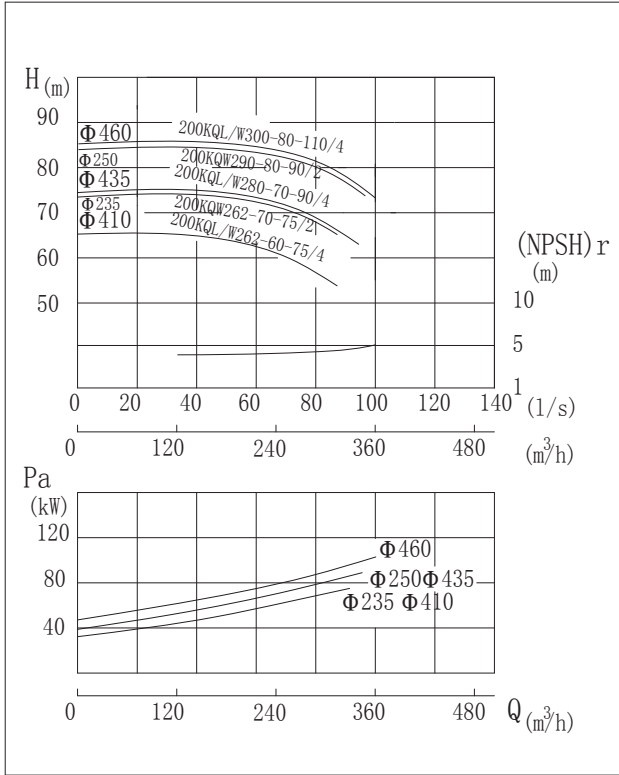

参数表PERFORMANCE DATA

型号 TYPE	流量 Capacity		扬程 Head (m)	转速 Speed (r/min)	效率 Efficiency (%)	电机 功率 Power (kW)	必需汽蚀 余量 (NPSH)r (m)	重量 Weight (kg)
	(m³/h)	(l/s)						
200KQL/W245-24-22/4	171	47.5	25.4	1480	82	22	4	455
	245	72.2	24					
	270	75.0	21.6					
200KQL/W280-28-30/4	196	54.4	30.6	1480	82	30	4	510
	280	77.8	28					
	308	85.6	26.2					
200KQL/W300-32-37/4	210	58.3	34.5	1480	83.8	37	4	615
	300	83.3	32					
	330	91.7	29.5					
200KQL/W260-38-45/4	182	50.6	41.4	1480	78	45	4	575
	260	72.2	38					
	312	86.7	29.6					
200KQL/W270-44-45/4	189	52.5	46.2	1480	80	45	4	648
	270	75.0	44					
	297	82.5	39.6					
200KQL/W300-48-55/4	210	58.3	50.4	1480	81.6	55	4	745
	300	83.3	48					
	330	91.7	43.2					
200KQL/W262-60-75/4	182	50.6	64	1480	73	75	4.5	888
	262	72.8	60					
	312	86.7	54					
200KQW262-70-75/2	182	50.6	78	2960	78	75	8	790
	262	72.8	70					
	312	86.7	65					
200KQL/W280-70-90/4	196	54.4	74	1480	75	90	4.5	986
	280	77.8	70					
	336	93.3	64					
200KQW290-80-90/2	203	56.4	92	2960	80	90	8	850
	290	80.6	80					
	348	96.7	69					
200KQL/W300-80-110/4	210	58.3	85	1480	76	110	4.5	1308
	300	83.3	80					
	360	100.0	73					

尺寸图DIMENSION FIGURE

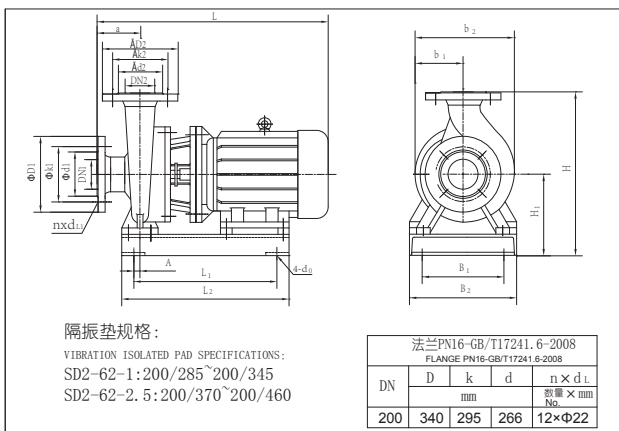

KQW尺寸表DIMENSION TABLE

型号 TYPE	外形尺寸 Figure dimensions				安装尺寸 Installing dimensions										DN1	DN2
	L	H	b <sub>2</sub>	b <sub>1</sub>	4-φd <sub>0</sub>	a	L <sub>1</sub>	B <sub>1</sub>	L <sub>2</sub>	B <sub>2</sub>	H <sub>1</sub>	A				
200KQW245-24-22/4	1030	918	529	250	4-φ20	160	670	430	770	560	418	50	200	200		
200KQW280-28-30/4	1030	918	590	280	4-φ20	160	670	430	770	560	418	50	200	200		
200KQW300-32-37/4	1040	918	590	280	4-φ20	160	670	430	770	560	418	50	200	200		
200KQW260-38-45/4	1065	876	577	280	4-φ20	160	695	430	795	560	418	50	200	200		
200KQW270-44-45/4	1065	876	577	280	4-φ20	160	695	430	795	560	418	50	200	200		
200KQW300-48-55/4	1125	876	572	280	4-φ20	160	760	430	860	560	418	50	200	200		
200KQW262-60-75/4	1225	1022	673	320	4-φ25	180	830	480	930	640	462	50	200	200		
200KQW262-70-75/2	1195	855	580	290	4-φ20	170	790	430	919	560	445	30	200	150		
200KQW280-70-90/4	1265	1022	673	320	4-φ25	180	880	480	980	640	462	50	200	200		
200KQW290-80-90/2	1245	855	580	290	4-φ20	170	840	430	970	560	445	30	200	150		
200KQW300-80-110/4	1530	1022	683	330	4-φ25	180	955	480	1055	640	462	50	200	200		

## 性能曲线CHARACTERISTIC CURVE

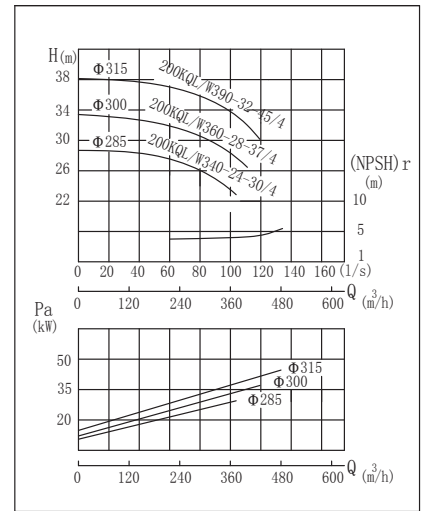
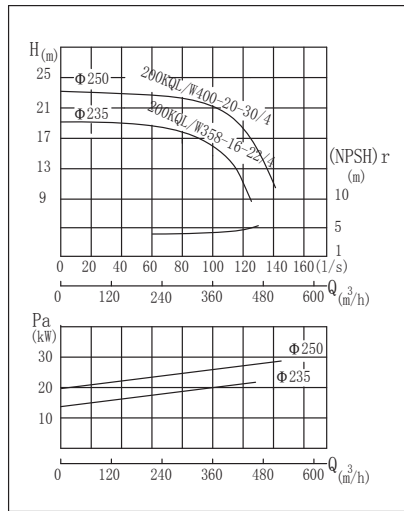
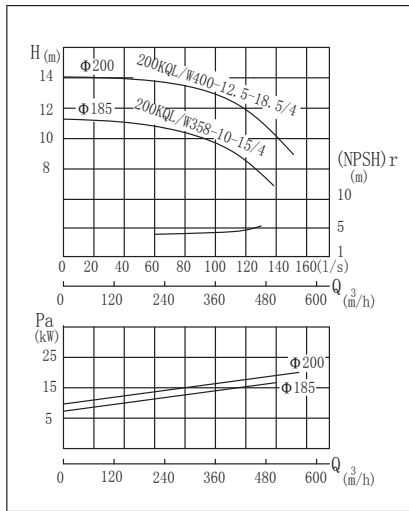

## 尺寸图DIMENSION FIGURE

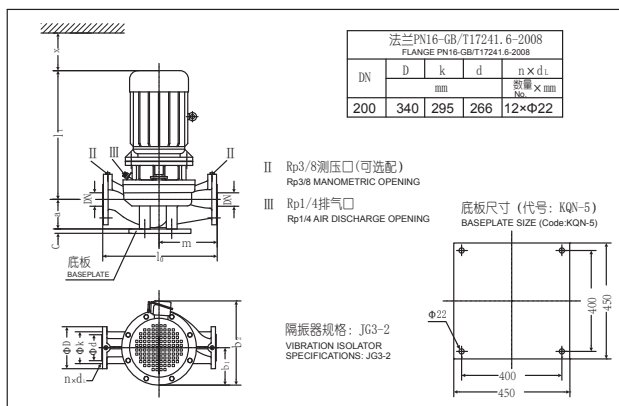

## KQL尺寸表DIMENSION TABLE

型号 TYPE	DN	mm							
		l <sub>0</sub>	m	a	c	l <sub>1</sub>	b <sub>1</sub>	b <sub>2</sub>	x
200KQL358-10-15/4	200	990	480	275	37	781	250	530	150
200KQL400-12.5-18.5/4	200	990	480	275	37	823	250	530	150
200KQL358-16-22/4	200	990	480	275	37	873	250	530	150
200KQL400-20-30/4	200	990	480	275	37	873	270	575	150
200KQL340-24-30/4	200	1000	500	295	37	876	270	575	155
200KQL360-28-37/4	200	1000	500	295	37	886	295	625	155
200KQL390-32-45/4	200	1000	500	295	37	911	295	625	155
200KQL340-36-45/4	200	1070	535	280	37	914	295	625	155
200KQL370-40-55/4	200	1070	535	280	37	976	315	680	155
200KQL374-44-75/4	200	1070	535	280	37	1035	360	760	155
200KQL400-50-75/4	200	1070	535	280	37	1035	360	760	155

性能曲线 CHARACTERISTIC CURVE

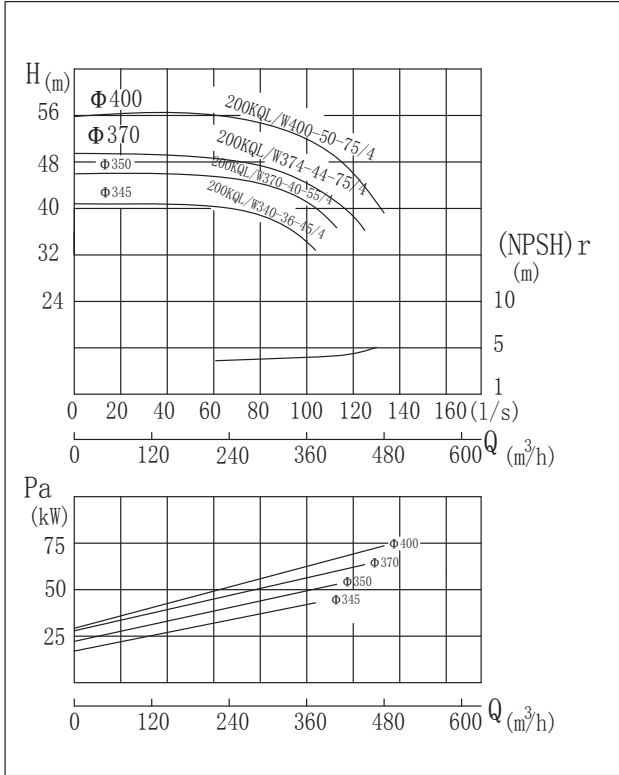

参数表 PERFORMANCE DATA

型号 TYPE	流量 Capacity		扬程 Head (m)	转速 Speed (r/min)	效率 Efficiency (%)	电机 功率 Power (kW)	必需汽蚀 余量 (NPSH)r (m)	重量 Weight (kg)
	3 (m³/h)	(l/s)						
200KQL/W358-10-15/4	250	69.4	13	1480	81	15	4	346
	358	99.4	10					
	394	109.4	7					
200KQL/W400-12.5-18.5/4	280	77.8	15.5	1480	82	18.5	4	380
	400	111.1	12.5					
	440	122.2	10.2					
200KQL/W358-16-22/4	250	69.4	18	1480	83	22	4	586
	358	99.4	16					
	430	119.4	11.2					
200KQL/W400-20-30/4	280	77.8	23	1480	84	30	4	454
	400	111.1	20					
	480	133.3	14					
200KQL/W340-24-30/4	238	66.1	25.2	1480	80	30	4	510
	340	96.1	24					
	374	103.9	21.6					
200KQL/W360-28-37/4	252	70.0	31.5	1480	81	37	4	560
	360	100.0	28					
	396	110.0	25					
200KQL/W390-32-45/4	273	75.8	34.5	1480	83.9	45	4	600
	390	108.3	32					
	429	119.2	28.8					
200KQL/W340-36-45/4	238	66.1	39	1480	80	45	4	605
	340	96.1	36					
	374	103.9	32.4					
200KQL/W370-40-55/4	259	71.9	45.5	1480	82	55	4	712
	370	102.8	40					
	407	113.1	36					
200KQL/W374-44-75/4	262	72.8	48	1480	81	75	4	828
	374	103.9	44					
	449	124.7	34					
200KQL/W400-50-75/4	280	77.8	54.5	1480	82.6	75	4	819
	400	111.1	50					
	480	133.3	39					

尺寸图 DIMENSION FIGURE

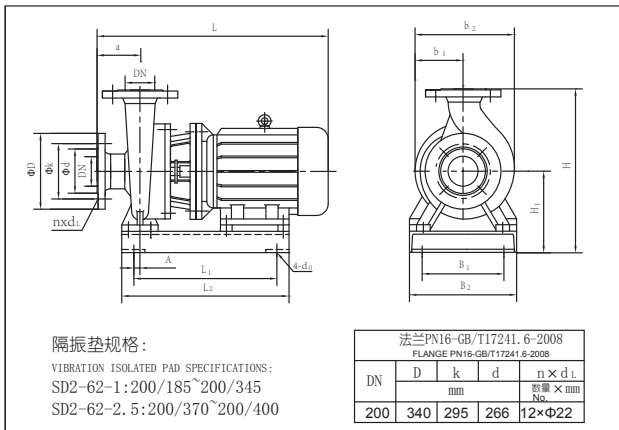

KQW尺寸表 DIMENSION TABLE

型号 TYPE	外形尺寸 Figure dimensions				安装尺寸 Installing dimensions								DN
	L	H	b <sub>2</sub>	b <sub>1</sub>	4-φ <sub>20</sub>	a	L <sub>1</sub>	B <sub>1</sub>	L <sub>2</sub>	B <sub>2</sub>	H <sub>1</sub>	A	
200KQW358-10-15/4	930	862	529	250	4-φ20	160	580	370	680	510	382	50	200
200KQW400-12.5-18.5/4	970	862	529	250	4-φ20	160	580	370	680	510	382	50	200
200KQW358-16-22/4	1020	862	529	250	4-φ20	160	615	370	715	510	382	50	200
200KQW400-20-30/4	1030	859	529	250	4-φ20	160	665	370	765	500	379	50	200
200KQW340-24-30/4	1030	918	572	280	4-φ20	160	670	430	770	560	418	50	200
200KQW360-28-37/4	1040	918	572	280	4-φ20	160	670	430	770	560	418	50	200
200KQW390-32-45/4	1065	918	572	280	4-φ20	160	695	430	795	560	418	50	200
200KQW340-36-45/4	1065	878	572	280	4-φ20	160	695	430	795	560	418	50	200
200KQW370-40-55/4	1125	878	572	280	4-φ20	160	760	430	860	560	418	50	200
200KQW374-44-75/4	1205	878	587	290	4-φ20	160	830	430	930	560	418	50	200
200KQW400-50-75/4	1205	878	587	290	4-φ20	160	830	430	930	560	418	50	200



## 性能曲线CHARACTERISTIC CURVE

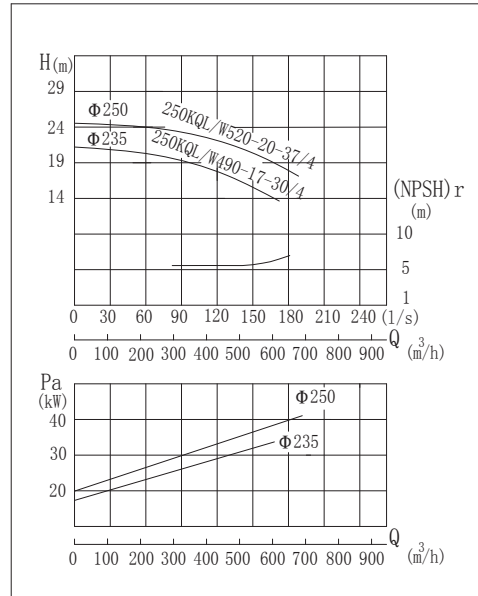
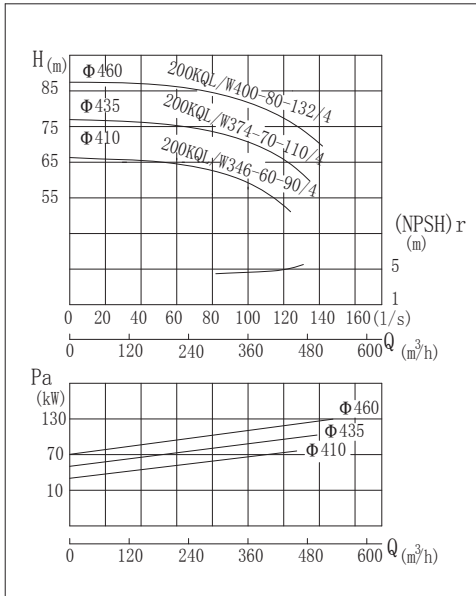

## 尺寸图DIMENSION FIGURE

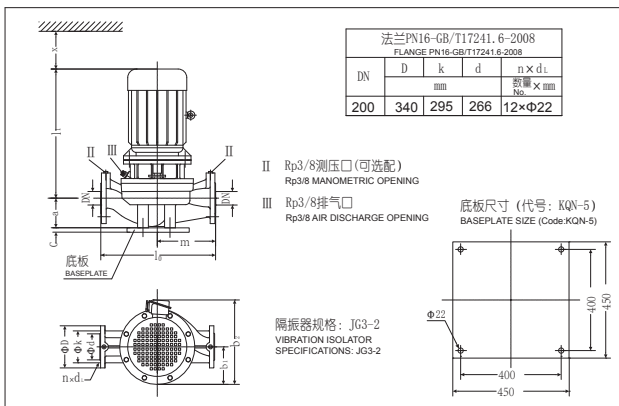

## KQL尺寸表DIMENSION TABLE

型号 TYPE	DN	$l_0$	$m$	$a$	$c$	$l_1$	$b_1$	$b_2$	$x$
		mm							
200KQL346-60-90/4	200	1170	560	320	37	1096	360	760	165
200KQL374-70-110/4	200	1170	560	320	37	1350	450	980	165
200KQL400-80-132/4	200	1170	560	320	37	1371	450	980	165

## 尺寸图DIMENSION FIGURE

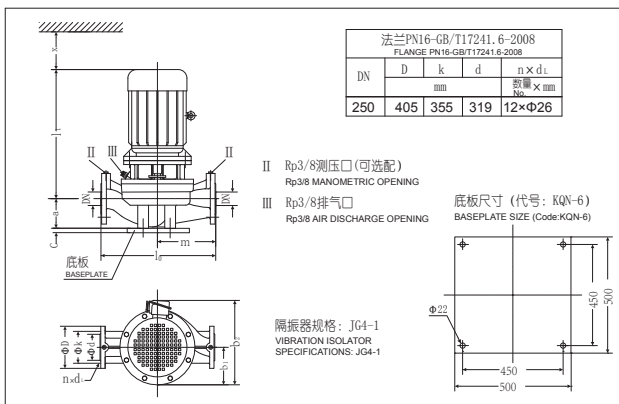

## KQL尺寸表DIMENSION TABLE

型号 TYPE	DN	$l_0$	$m$	$a$	$c$	$l_1$	$b_1$	$b_2$	$x$
		mm							
250KQL490-17-30/4	250	1100	550	335	40	864	295	660	180
250KQL520-20-37/4	250	1100	550	335	40	870	295	660	180
250KQL500-25-45/4	250	1100	550	335	40	915	295	660	180
250KQL500-28-55/4	250	1100	550	335	40	959	360	660	180
250KQL550-32-75/4	250	1100	550	335	40	1039	360	760	180

### 性能曲线CHARACTERISTIC CURVE

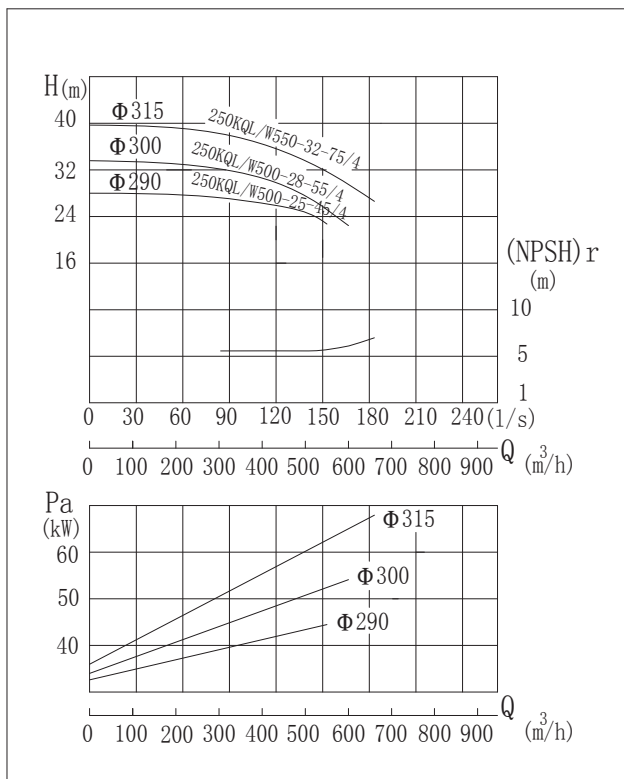

### 参数表PERFORMANCE DATA

型号 TYPE	流量 Capacity		扬程 Head (m)	转速 Speed (r/min)	效率 Efficiency (%)	电机 功率 Power (kW)	必需汽蚀 余量 (NPSH)r (m)	重量 Weight (kg)
	3 (m³/h)	(l/s)						
200KQL/W346-60-90/4	242	67.2	64	1480	75	90	4.5	935
	346	96.1	60					
	415	115.3	54					
200KQL/W374-70-110/4	262	72.8	74	1480	77	110	4.5	1276
	374	103.9	70					
	449	124.7	64					
200KQL/W400-80-132/4	280	77.8	85	1480	78.5	132	4.5	1380
	400	111.1	80					
	480	133.3	73					
250KQL/W490-17-30/4	343	95.3	19	1480	83.5	30	5.5	545
	490	136.1	17					
	539	149.7	15.3					
250KQL/W520-20-37/4	364	101.1	22	1480	84.5	37	5.5	630
	520	144.4	20					
	572	158.9	18					
250KQL/W500-25-45/4	350	97.2	26.2	1480	84.7	45	5.5	622
	500	138.9	25					
	550	152.8	22.5					
250KQL/W500-28-55/4	364	101.1	31.5	1480	83	55	5.5	716
	500	138.9	28					
	600	166.7	25					
250KQL/W550-32-75/4	400	111.1	33.5	1480	85	75	5.5	852
	550	152.8	32					
	660	183.3	29					

### 尺寸图DIMENSION FIGURE

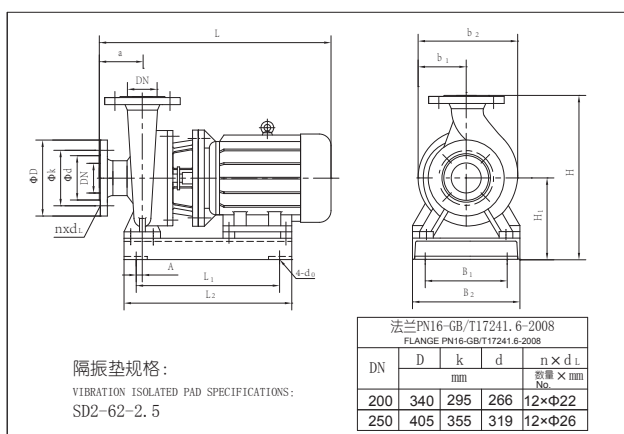

### KQW尺寸表DIMENSION TABLE

型号 TYPE	外形尺寸 Figure dimensions				安装尺寸 Installing dimensions								DN
	L	H	b <sub>2</sub>	b <sub>1</sub>	4-φ <sub>0</sub>	a	L <sub>1</sub>	B <sub>1</sub>	L <sub>2</sub>	B <sub>2</sub>	H <sub>1</sub>	A	
200KQW346-60-90/4	1265	1022	661	320	4-φ25	180	880	480	980	640	462	50	200
200KQW374-70-110/4	1530	1022	683	330	4-φ25	180	955	480	1055	640	462	50	200
200KQW400-80-132/4	1560	1022	683	330	4-φ25	180	1005	480	1150	640	462	50	200
250KQW490-17-30/4	1074	989	690	300	4-φ20	200	630	500	795	640	441	30	250
250KQW520-20-37/4	1084	989	690	300	4-φ20	200	630	500	780	640	439	30	250
250KQW500-25-45/4	1109	989	690	320	4-φ20	200	630	500	805	640	439	30	250
250KQW500-28-55/4	1169	989	660	320	4-φ20	200	630	500	880	640	439	30	250
250KQW550-32-75/4	1245	989	660	320	4-φ20	200	710	500	935	640	439	30	250

## 性能曲线CHARACTERISTIC CURVE

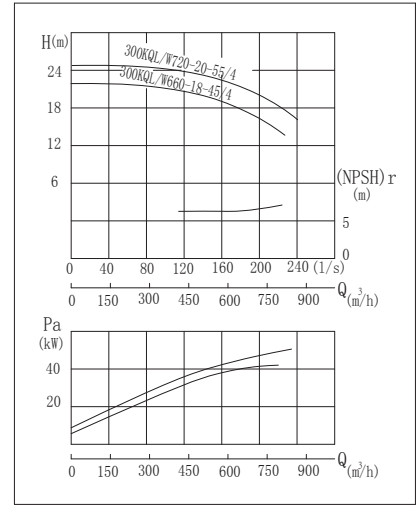
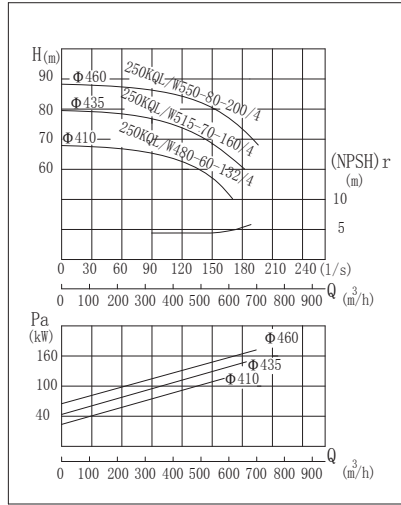
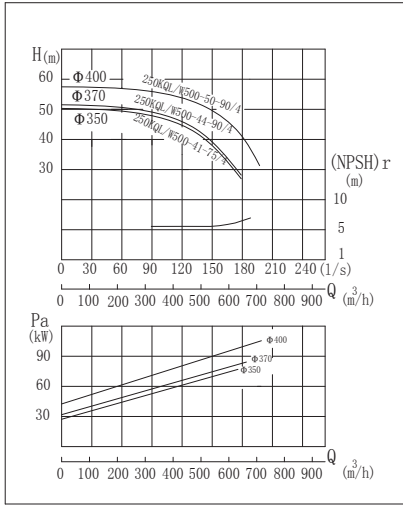

## 尺寸图DIMENSION FIGURE

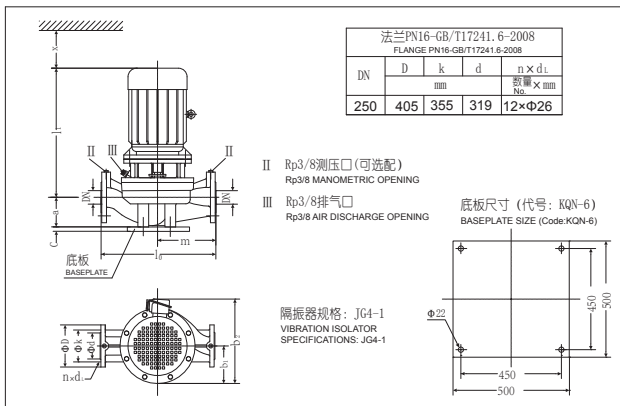

## KQL尺寸表DIMENSION TABLE

型号 TYPE	DN	l <sub>0</sub>	m	a	c	l <sub>1</sub>	b <sub>1</sub>	b <sub>2</sub>	x
		mm							
250KQL500-41-75/4	250	1200	600	335	40	1035	360	760	205
250KQL500-44-90/4	250	1200	600	335	40	1085	360	760	205
250KQL500-50-90/4	250	1200	600	335	40	1085	360	760	205
250KQL480-60-132/4	250	1360	650	380	40	1396	450	880	205
250KQL515-70-160/4	250	1360	650	380	40	1380	450	880	205
250KQL550-80-200/4	250	1360	650	380	40	1380	450	880	205

## 尺寸图DIMENSION FIGURE

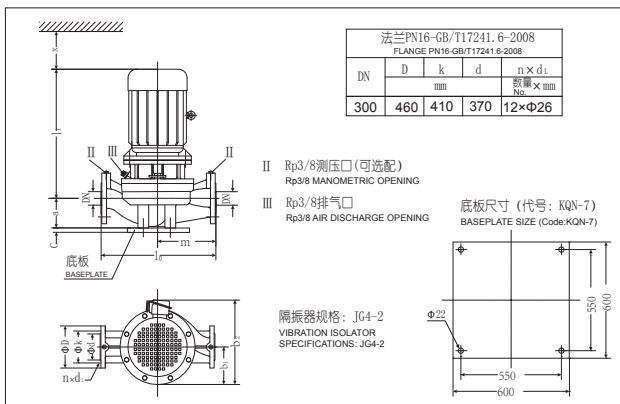

## KQL尺寸表DIMENSION TABLE

型号 TYPE	DN	l <sub>0</sub>	m	a	c	l <sub>1</sub>	b <sub>1</sub>	b <sub>2</sub>	x
		mm							
300KQL660-18-45/4	300	1250	625	390	45	937	305	710	230
300KQL720-20-55/4	300	1250	625	390	45	1001	325	725	230
300KQL600-24-55/4	300	1250	625	390	45	1001	325	725	230
300KQL660-28-75/4	300	1250	625	390	45	1077	360	760	230
300KQL720-32-90/4	300	1250	625	390	45	1115	360	760	230

性能曲线CHARACTERISTIC CURVE

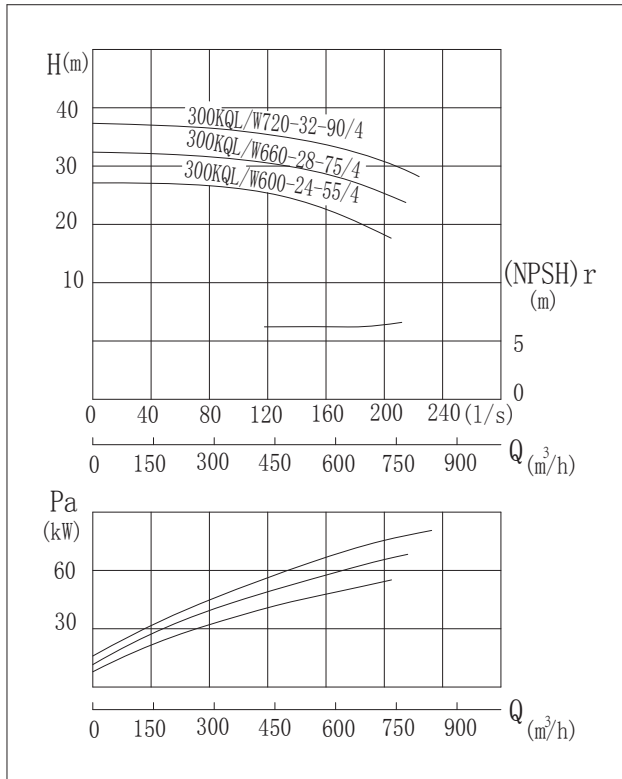

参数表PERFORMANCE DATA

型号 TYPE	流量 Capacity		扬程 Head (m)	转速 Speed (r/min)	效率 Efficiency (%)	电机 功率 Power (kW)	必需汽蚀 余量 (NPSH)r (m)	重量 Weight (kg)
	(m³/h)	(l/s)						
250KQL/W500-41-75/4	350	97.2	44	1480	83	75	5.5	930
	500	138.9	41					
	550	152.8	36.9					
250KQL/W500-44-90/4	365	101.4	47	1480	80	90	5.5	970
	500	138.9	44					
	600	166.7	35					
250KQL/W500-50-90/4	350	97.2	52.5	1480	84.1	90	5.5	1035
	500	138.9	50					
	550	152.8	45					
250KQL/W480-60-132/4	350	97.2	64	1480	79	132	4.5	1492
	480	133.3	60					
	580	161.1	52.5					
250KQL/W515-70-160/4	375	104.2	74	1480	80	160	4.5	1510
	515	143.0	70					
	620	172.2	61.2					
250KQL/W550-80-200/4	400	111.1	85	1480	81.6	200	4.5	1697
	550	152.8	80					
	660	183.3	73					
300KQL/W660-18-45/4	460	127.8	20	1480	82	45	6.0	710
	660	183.3	17.5					
	790	219.4	14					
300KQL/W720-20-55/4	500	138.9	23	1480	84.2	55	6.0	820
	720	200.0	20					
	860	239.0	16					
300KQL/W600-24-55/4	420	116.7	26.5	1480	81	55	6.0	805
	600	166.7	24					
	720	200.0	20.6					
300KQL/W660-28-75/4	460	127.8	30.5	1480	83	75	6.0	938
	660	183.3	28					
	790	219.4	24					
300KQL/W720-32-90/4	500	138.9	35	1480	85.8	90	6.0	1043
	720	200.0	32					
	860	239.0	28					

尺寸图DIMENSION FIGURE

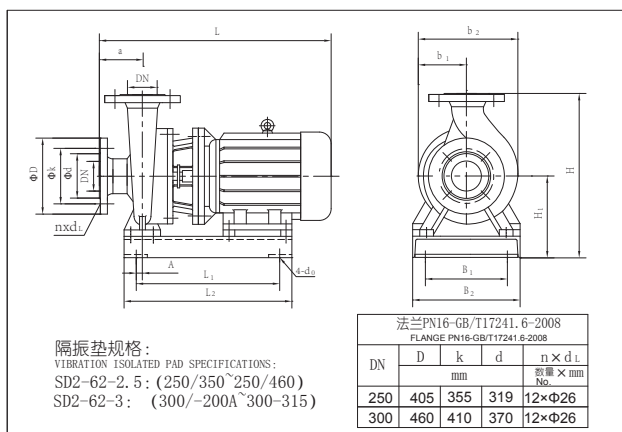

KQW尺寸表DIMENSION TABLE

型号 TYPE	外形尺寸 Figure dimensions				安装尺寸 Installing dimensions								DN
	L	H	b <sub>2</sub>	b <sub>1</sub>	4-φ <sub>0</sub>	a	L <sub>1</sub>	B <sub>1</sub>	L <sub>2</sub>	B <sub>2</sub>	H <sub>1</sub>	A	
250KQW500-41-75/4	1245	1039	690	300	4-φ20	200	710	500	935	640	464	30	250
250KQW500-44-90/4	1285	1039	690	300	4-φ20	200	710	500	985	640	464	30	250
250KQW500-50-90/4	1285	1039	690	330	4-φ20	200	710	500	985	640	464	30	250
250KQW480-60-132/4	1600	1144	731	341	4-φ25	220	900	550	1170	640	494	30	250
250KQW515-70-160/4	1600	1144	731	341	4-φ25	220	900	550	1170	640	494	30	250
250KQW550-80-200/4	1600	1144	731	341	4-φ25	220	900	550	1170	640	494	30	250
300KQW660-18-45/4	1178	1081	695	300	4-φ25	253	710	430	930	560	484	110	300
300KQW720-20-55/4	1238	1081	695	300	4-φ25	253	780	430	975	640	484	110	300
300KQW600-24-55/4	1238	1081	695	300	4-φ25	253	780	430	1000	640	481	110	300
300KQW660-28-75/4	1318	1081	695	300	4-φ25	253	850	430	1015	640	481	110	300
300KQW720-32-90/4	1358	1081	720	300	4-φ25	253	890	430	1065	640	481	110	300

## 性能曲线CHARACTERISTIC CURVE

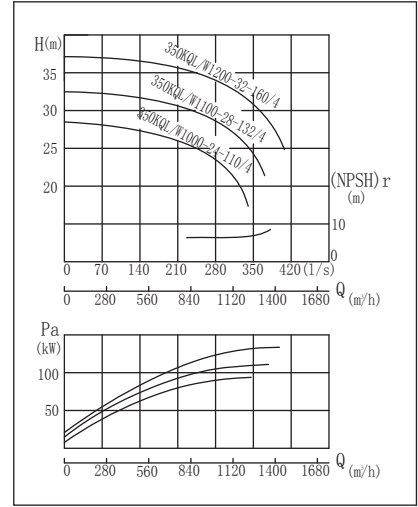
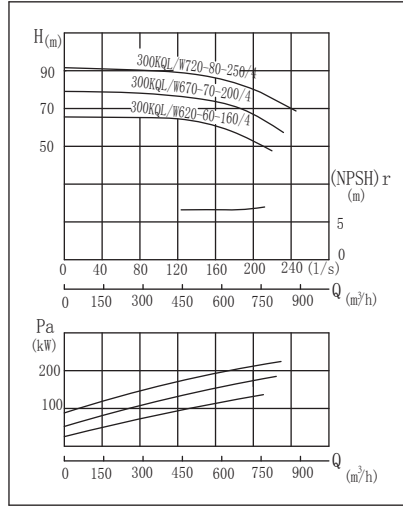
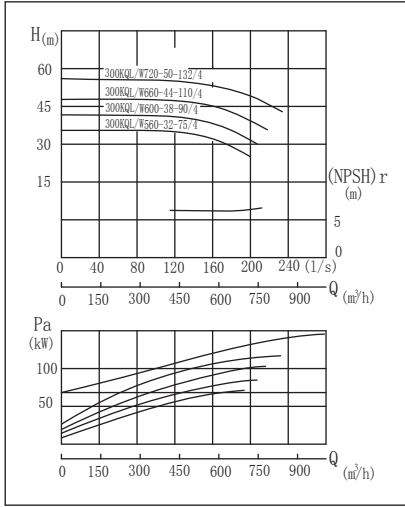

## 尺寸图DIMENSION FIGURE

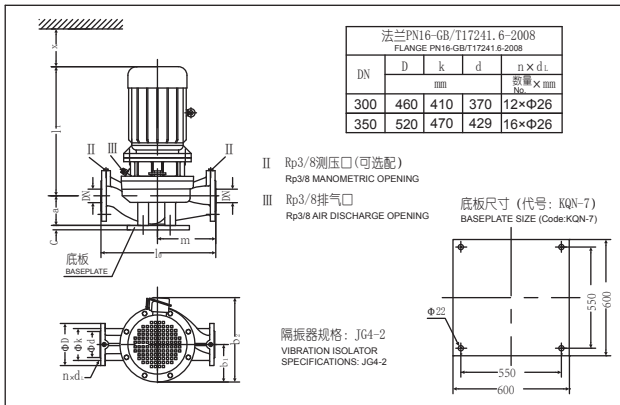

## KQL尺寸表DIMENSION TABLE

型号 TYPE	DN	l <sub>0</sub>	m	a	c	l <sub>1</sub>	b <sub>1</sub>	b <sub>2</sub>	x
		mm							
300KQL560-32-75/4	300	1300	650	400	45	1045	385	835	230
300KQL600-38-90/4	300	1300	650	400	45	1095	385	835	230
300KQL660-44-110/4	300	1300	650	400	45	1350	450	980	230
300KQL720-50-132/4	300	1300	650	400	45	1380	450	980	230
350KQL1000-24-110/4	350	1350	600	470	45	1350	450	980	250
350KQL1100-28-132/4	350	1350	600	470	45	1380	450	980	250
350KQL1200-32-160/4	350	1350	600	470	45	1380	450	980	250
350KQL820-24-90/4	350	1350	600	470	45	1095	360	770	250
350KQL860-28-110/4	350	1350	600	470	45	1350	450	980	250
350KQL960-32-132/4	350	1350	600	470	45	1380	450	980	250

性能曲线CHARACTERISTIC CURVE

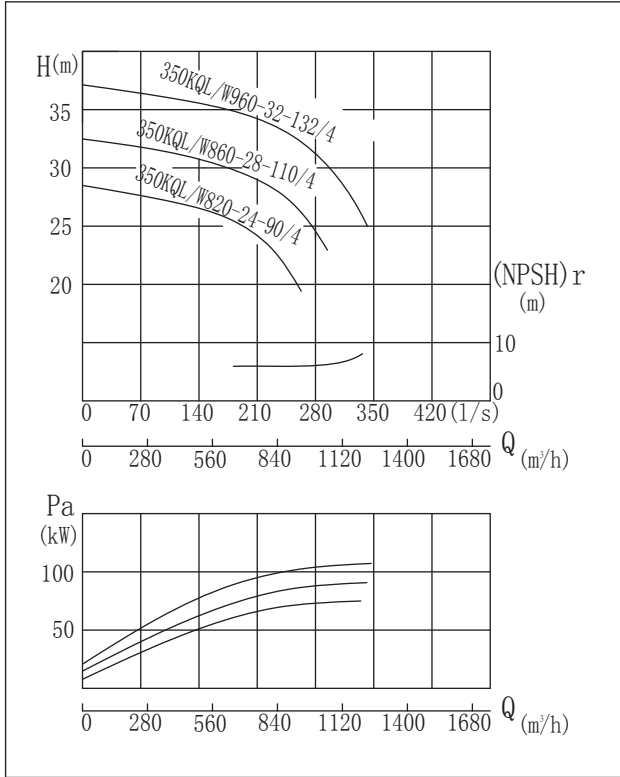

参数表PERFORMANCE DATA

型号 TYPE	流量 Capacity		扬程 Head (m)	转速 Speed (r/min)	效率 Efficiency (%)	电机 功率 Power (kW)	必需汽蚀 余量 (NPSH)r (m)	重量 Weight (kg)
	(m³/h)	(l/s)						
300KQL/W560-32-75/4	390	108.3	36	1480	79	75	6.0	980
	560	155.6	32					
	670	186.1	28					
300KQL/W600-38-90/4	420	116.7	42	1480	81	90	6.0	1200
	600	166.7	38					
	720	200	34					
300KQL/W660-44-110/4	460	127.8	49	1480	83	110	6.0	1550
	660	183.3	44					
	790	219.4	37					
300KQL/W720-50-132/4	500	138.9	55	1480	85.8	132	6.0	1650
	720	200	50					
	860	239	42					
300KQW620-60-160/4	430	119.4	64.5	1480	79	160	6.5	1720
	620	172.2	60					
	740	205.6	54					
300KQW670-70-200/4	465	129.2	75	1480	81	200	6.5	1757
	670	186.1	70					
	800	222.2	60.4					
300KQW720-80-250/4	500	138.9	86	1480	83.8	250	6.5	2342
	720	200.0	80					
	860	239.0	69					
350KQL/W1000-24-110/4	750	208.3	27	1480	81	110	9	1335
	1000	277.8	24					
	1200	333.3	20					
350KQL/W1100-28-132/4	820	227.8	31	1480	83	132	9	1490
	1100	305.6	28					
	1300	361.1	23					
350KQL/W1200-32-160/4	900	250	36	1480	86.3	160	9	1870
	1200	333.3	32					
	1400	400	27					
350KQL/W820-24-90/4	574	159	26.5	1480	80	90	8	1335
	820	228	24					
	984	273	19.5					
350KQL/W860-28-110/4	602	167	31	1480	82	110	8	1365
	860	239	28					
	1032	287	23					
350KQL/W960-32-132/4	672	187	35	1480	85	132	8	1452
	960	267	32					
	1152	320	27.5					

尺寸图DIMENSION FIGURE

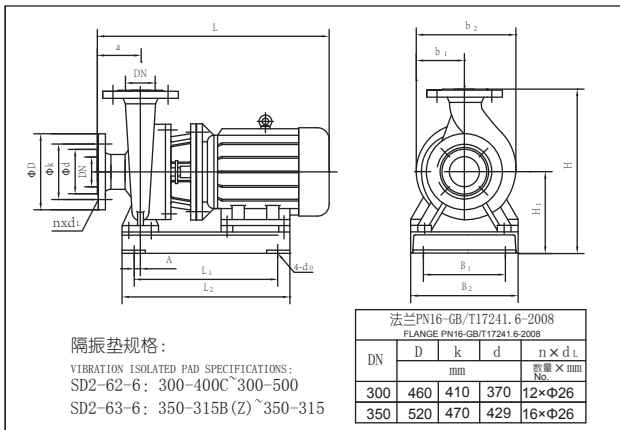

KQW尺寸表DIMENSION TABLE

型号 TYPE	外形尺寸				安装尺寸								DN
	Figure dimensions				Installing dimensions								
	L	H	b <sub>2</sub>	b <sub>1</sub>	4-φ <sub>25</sub>	a	L <sub>1</sub>	B <sub>1</sub>	L <sub>2</sub>	B <sub>2</sub>	H <sub>1</sub>	A	
300KQW560-32-75/4	1295	1134	674	320	4-φ25	250	750	550	975	640	484	30	300
300KQW600-38-90/4	1355	1134	674	320	4-φ25	250	800	550	1025	640	484	30	300
300KQW660-44-110/4	1600	1134	674	320	4-φ25	250	850	550	1090	640	484	30	300
300KQW720-50-132/4	1630	1134	674	320	4-φ25	250	950	550	1195	640	484	30	300
300KQW620-60-160/4	1630	1400	835	390	4-φ25	250	900	625	1185	720	600	30	300
300KQW670-70-200/4	1620	1400	835	390	4-φ25	250	900	625	1185	720	600	30	300
300KQW720-80-250/4	1840	1382	846	400	4-φ25	250	1020	650	1315	750	582	30	300
350KQW1000-24-110/4	1600	1117	720	323	4-φ25	250	920	550	1090	640	520	50	350
350KQW1100-28-132/4	1630	1117	720	323	4-φ25	250	1020	550	1200	640	520	50	350
350KQW1200-32-160/4	1630	1117	720	323	4-φ25	250	1020	550	1200	640	520	50	350
350KQW820-24-90/4	1345	1117	720	323	4-φ25	250	900	550	1055	640	520	50	350
350KQW860-28-110/4	1600	1117	720	323	4-φ25	250	920	550	1090	640	520	50	350
350KQW960-32-132/4	1630	1117	720	323	4-φ25	250	1020	550	1200	640	520	50	350

## 性能曲线CHARACTERISTIC CURVE

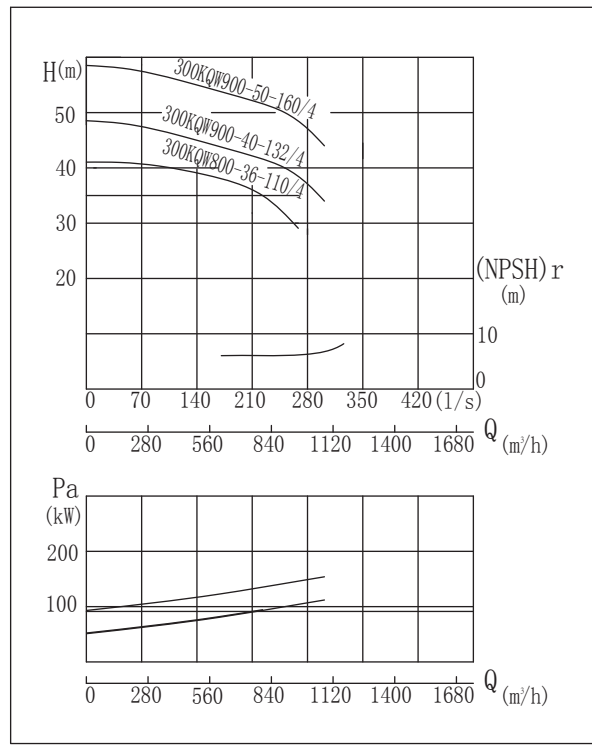
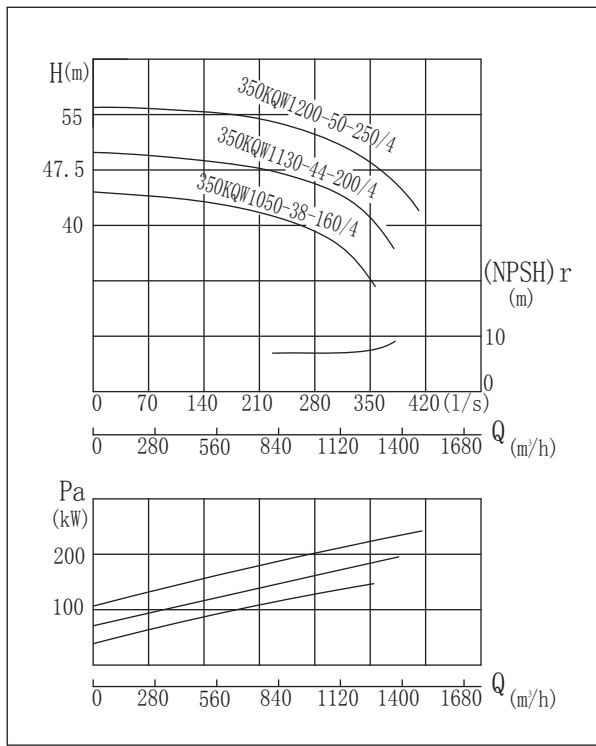

## 尺寸图DIMENSION FIGURE

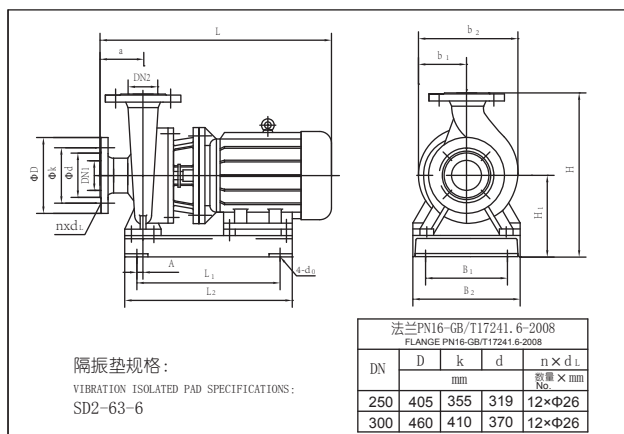

## KQL尺寸表DIMENSION TABLE

型号 TYPE	外形尺寸				安装尺寸								DN1	DN2
	Figure dimensions				Installing dimensions									
	L	H	b <sub>2</sub>	b <sub>1</sub>	4-d <sub>0</sub>	a	L <sub>1</sub>	B <sub>1</sub>	L <sub>2</sub>	B <sub>2</sub>	H <sub>1</sub>	A		
300KQW800-36-110/4	1620	1179	980	450	4-φ25	290	900	550	1150	640	509	30	300	250
300KQW900-40-132/4	1650	1179	980	450	4-φ25	290	950	550	1195	640	509	30	300	250
300KQW900-50-160/4	1650	1179	980	450	4-φ25	290	950	550	1195	640	509	30	300	250



性能曲线CHARACTERISTIC CURVE

型号 TYPE	流量 Capacity		扬程 Head (m)	转速 Speed (r/min)	效率 Efficiency (%)	电机 功率 Power (kW)	必需汽蚀 余量 (NPSH)r (m)	重量 Weight (kg)
	(m <sup>3</sup> /h)	(l/s)						
300KQW800-36-110/4	560	155.6	42	1480	83	110	6	1480
	800	222.2	36					
	960	266.7	29					
300KQW900-40-132/4	630	175	46	1480	84.5	132	6	1585
	900	250	40					
	1080	300	34					
300KQW900-50-160/4	630	175	56.5	1480	86	160	6	1590
	900	250	50					
	1080	300	44					
350KQW1050-38-160/4	790	219.4	41	1480	83	160	9	2350
	1050	291.7	38					
	1225	340.3	32.7					
350KQW1130-44-200/4	850	236.1	46.6	1480	85	200	9	2440
	1130	313.9	44					
	1320	366.7	38					
350KQW1200-50-250/4	900	250	53	1480	87.1	250	9	2500
	1200	333.3	50					
	1400	400	44					

尺寸图DIMENSION FIGURE

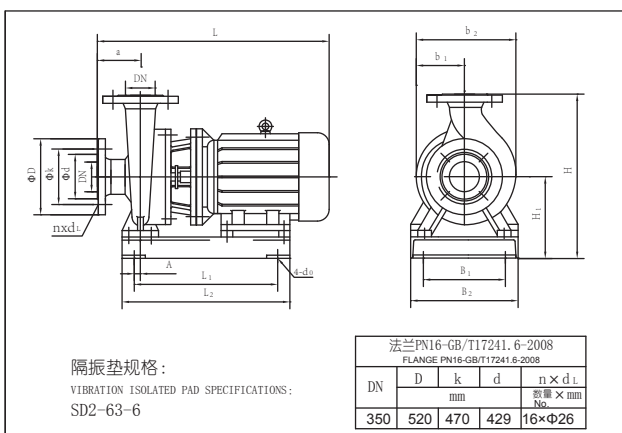

KQW尺寸表DIMENSION TABLE

型号 TYPE	外形尺寸				安装尺寸								DN
	Figure dimensions				Installing dimensions								
	L	H	b <sub>2</sub>	b <sub>1</sub>	4-d <sub>0</sub>	a	L <sub>1</sub>	B <sub>1</sub>	L <sub>2</sub>	B <sub>2</sub>	H <sub>1</sub>	A	
350KQW1050-38-160/4	1680	1267	785	360	4-φ25	270	1035	625	1235	720	567	50	350
350KQW1130-44-200/4	1680	1267	785	360	4-φ25	270	1035	625	1235	720	567	50	350
350KQW1200-50-250/4	1890	1251	825	400	4-φ25	270	1150	650	1355	750	551	50	350

## 附件及安装基础尺寸图表 ACCESSORIES AND INSTALLING BASIC DIMENSIONS CHART

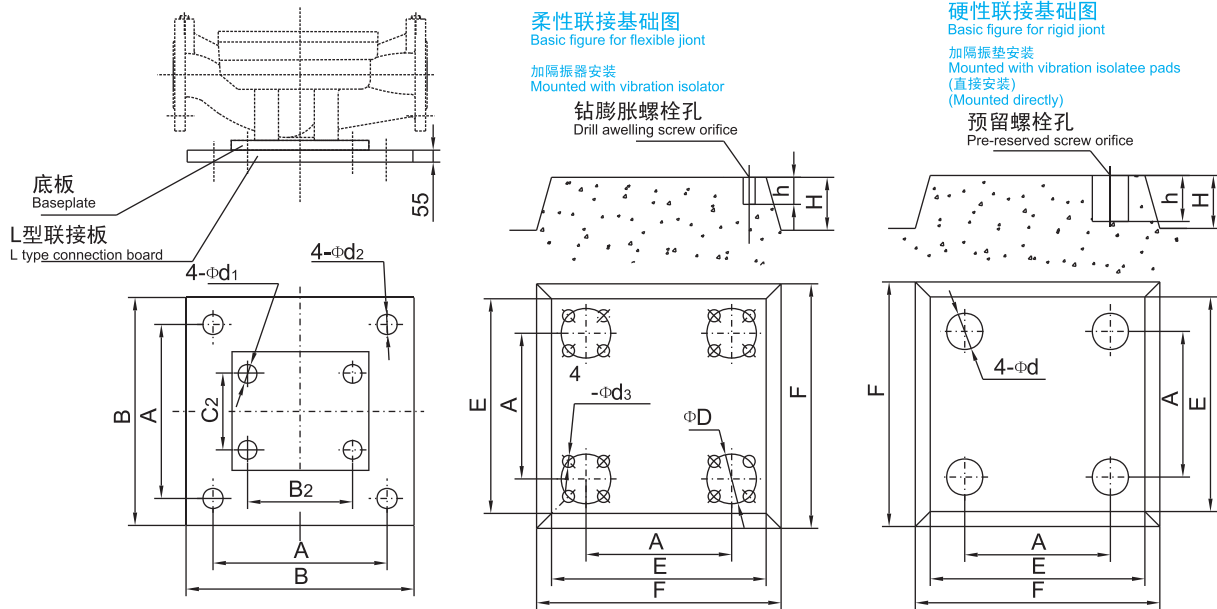

### I. 底板与基础直接联接 (不带L型联接板) I. Baseplate connected with base directly (without L type of connection board)

底板代号 Baseplate code (尺寸详见各尺寸图) (Dimensions appear in each figure)	Φd1	柔性联接基础尺寸图 Basic figure for flexible joint dimensions							硬性联接基础尺寸图 Basic figure for rigid joint dimensions							地脚螺栓 GB799-88
		H	E	F	A	ΦD	Φd3	h	H	E	F	A	d	h		
KQN-1	14	200	360	400	160	同 隔 振 器 D1 Just the same with D1	10.5	40	200	360	400	160	60	200	M12×220	
KQN-2	14	200	400	450	210		10.5	40	200	400	450	210	60	200		
KQN-3	18	200	500	550	290		14.5	60	300	500	550	290	80	300	M16×300	
KQN-4	18	250	600	650	360		14.5	60	300	600	650	360	80	300		
KQN-5	22	250	650	700	400		14.5	60	300	650	700	400	80	300	M20×300	
KQN-6	22	300	800	900	450		14.5	60	300	800	900	450	80	300		
KQN-7	22	300	1000	1100	550		14.5	60	300	1000	1100	550	80	300		

### II. 配L型联接板安装 II. Mounted with L type of connection board

L型联接板尺寸 Dimensions of L type of connection board				柔性联接基础尺寸图 Basic figure for flexible joint dimensions							硬性联接基础尺寸图 Basic figure for rigid joint dimensions							地脚螺栓 GB799-88	
型号 Type	C2xB2	A	B	Φd1	Φd2	H	E	F	A	ΦD	Φd3	h	H	E	F	A	Φd		h
L-0	60x100	240	300	14	14	200	450	500	240	同 隔 振 器 D1 Just the same with D1	/	/	200	450	500	240	60	200	M12×220
L-1	160x160	240	300	14	14	200	450	500	240		10.5	40	200	450	500	240	60	200	
L-2	210x210	340	400	14	14	200	650	700	340		10.5	40	200	650	700	340	80	200	M16×300
L-3	290x290	440	500	18	18	300	750	800	440		10.5	40	300	750	800	440	80	300	
L-4	360x360	540	600	18	18	300	850	900	540		14.5	60	300	850	900	540	80	300	M20×300
L-5	400x400	640	700	22	22	300	950	1000	640		14.5	60	300	950	1000	640	80	300	
L-6	450x450	740	800	22	22	350	1100	1200	740		14.5	60	350	1000	1100	740	80	300	
L-7	550x550	840	900	22	22	350	1200	1300	840	14.5	60	350	1200	1300	840	80	300		

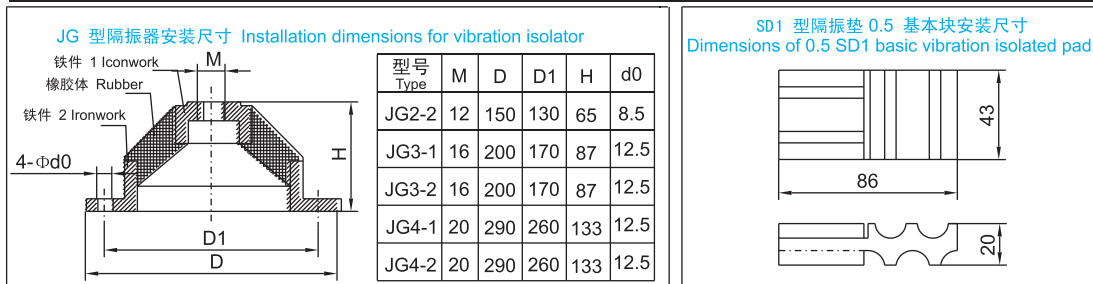

注：1. 本公司产品经精心加工装配，振动小。故建议一般不采用安装隔振器、隔振垫。各尺寸图中所注隔振器（垫）规格为推荐规格。  
2. 一般情况下，推荐采用底板与基础直接联接方式。  
Note: 1. Kaiquan product features less vibration due to elaborate machinery and assembly. It is recommended not to employ vibration isolator or isolated pads. The specifications of each dimension figure are recommended.  
2. In general, it is recommended to baseplate connected with base directly.

## KQL 允许的安装方式 INSTALLATION MODE

1. 直接安装 (7.5KW以下)  
Direct installation

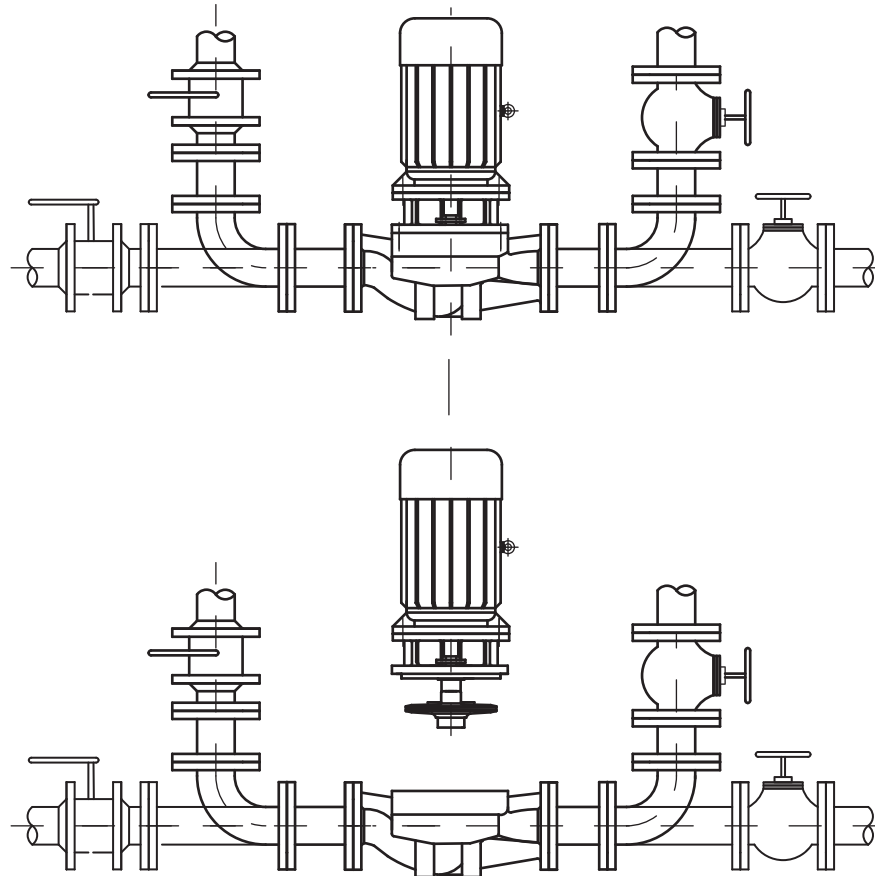

2. 地基支撑硬性联接  
Rigid joint with base support

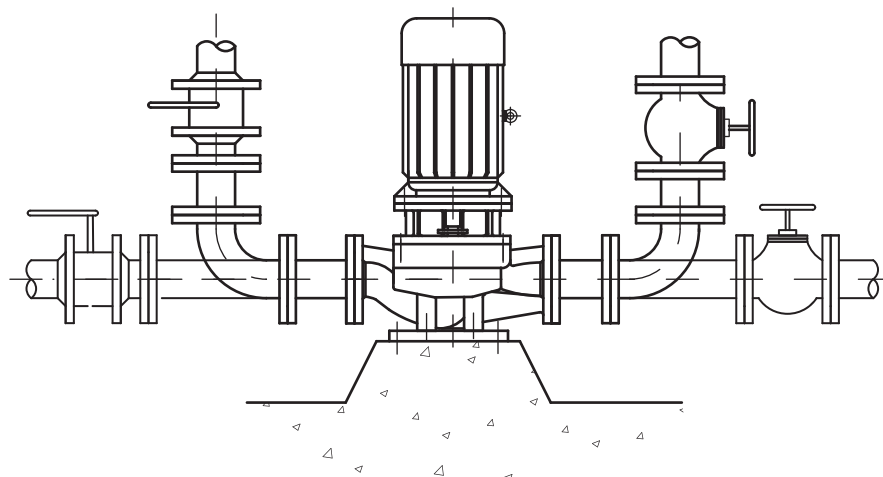

3. 地基支撑柔性联接  
Flexible joint with base support

3.1 配底板加隔振器  
Installed with baseplate and vibration isolator

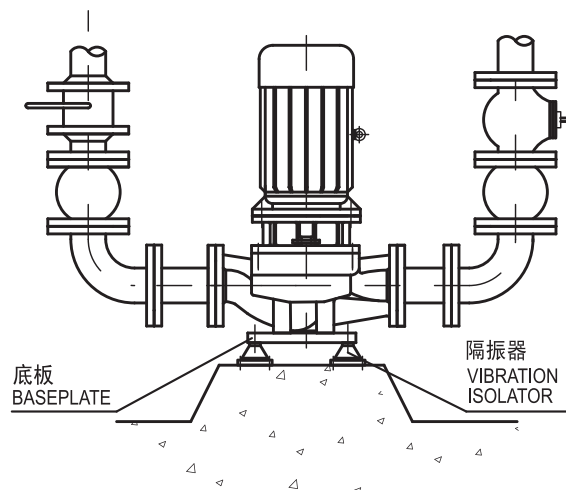

3.2 配底板加隔振垫  
Installed with baseplate and vibration isolated pads

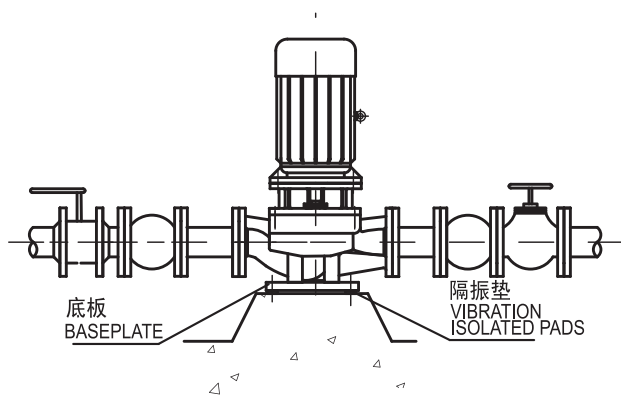

4. 悬臂卧式安装 (7.5KW以下)  
Cantilever horizontal

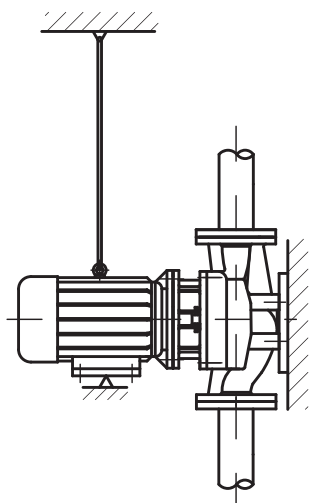

5. 户外使用: 采用户外电机  
For outdoor usage: Adopt outdoor type motor

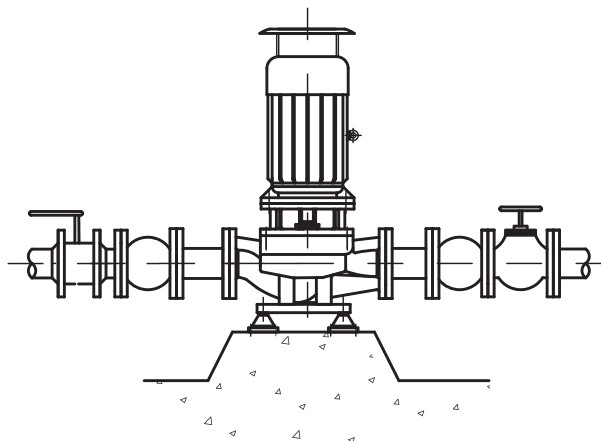



与原型号对照表

序号	型号	原型号	序号	型号	原型号
1	50KQL/W10-11-0.75/2	50/90-0.75/2	49	100KQL/W100-12.5-5.5/2	100/100-5.5/2
2	50KQL/W12.5-12.5-1.1/2	50/100-1.1/2	50	100KQL/W85-16-5.5/2	100/110S-5.5/2
3	50KQL/W11-16-1.1/2	50/110-1.1/2	51	100KQL/W95-20-7.5/2	100/125S-7.5/2
4	50KQL/W12.5-20-1.5/2	50/125-1.5/2	52	100KQL/W80-24-7.5/2	100/140S-7.5/2
5	50KQL/W10-27-1.5/2	50/150S-1.5/2	53	100KQL/W94-28-11/2	100/150-11/2
6	50KQL/W12.5-32-2.2/2	50/160S-2.2/2	54	100KQL/W100-32-15/2	100/160-15/2
7	50KQL/W10-36-3/2	50/170S-3/2	55	100KQL/W115-34-15/2	100/165-15/2
8	50KQL/W12-44-4/2	50/185S-4/2	56	100KQL/W94-44-18.5/2	100/185-18.5/2
9	50KQL/W12.5-50-5.5/2	50/200S-5.5/2	57	100KQL/W100-50-22/2	100/200-22/2
10	65KQL/W22-10-1.1/2	65/90-1.1/2	58	100KQL/W87-60-30/2	100/220-30/2
11	65KQL/W25-12.5-1.5/2	65/100-1.5/2	59	100KQL/W94-70-30/2	100/235-30/2
12	65KQL/W22-16-2.2/2	65/110-2.2/2	60	100KQL/W100-80-37/2	100/250-37/2
13	65KQL/W25-20-2.2/2	65/125S-2.2/2	61	100KQL/W82-85-37/2	100/270-37/2
14	65KQL/W20-24-2.2/2	65/140S-2.2/2	62	100KQL/W90-101-45/2	100/285-45/2
15	65KQL/W23-28-3/2	65/150S-3/2	63	100KQL/W95-113-55/2	100/300-55/2
16	65KQL/W25-32-4/2	65/160-4/2	64	100KQL/W100-125-75/2	100/315-75/2
17	65KQL/W22-38-5.5/2	65/170S-5.5/2	65	100KQL/W50-8-2.2/4	100/160-2.2/4
18	65KQL/W23-44-5.5/2	65/185S-5.5/2	66	100KQL/W45-10-2.2/4	100/185-2.2/4
19	65KQL/W25-50-7.5/2	65/200S-7.5/2	67	100KQL/W50-12.5-3/4	100/200-3/4
20	80KQL/W45-10-2.2/2	80/90-2.2/2	68	100KQL/W47-17-4/4	100/235-4/4
21	80KQL/W50-12.5-3/2	80/100-3/2	69	100KQL/W50-20-5.5/4	100/250-5.5/4
22	80KQL/W45-16-3/2	80/110S-3/2	70	100KQL/W47-28-7.5/4	100/300-7.5/4
23	80KQL/W50-20-4/2	80/125S-4/2	71	100KQL/W50-32-11/4	100/315-11/4
24	80KQL/W40-24-4/2	80/140S-4/2	72	125KQL/W143-10-7.5/2	125/90-7.5/2
25	80KQL/W47-28-5.5/2	80/150S-5.5/2	73	125KQL/W160-12.5-11/2	125/100-11/2
26	80KQL/W50-32-7.5/2	80/160-7.5/2	74	125KQL/W143-16-11/2	125/110-11/2
27	80KQL/W35-34-5.5/2	80/165-5.5/2	75	125KQL/W160-20-15/2	125/125-15/2
28	80KQL/W44-38-7.5/2	80/170-7.5/2	76	125KQL/W138-24-15/2	125/140-15/2
29	80KQL/W47-44-11/2	80/185-11/2	77	125KQL/W150-28-18.5/2	125/150-18.5/2
30	80KQL/W50-50-15/2	80/200-15/2	78	125KQL/W160-32-22/2	125/160-22/2
31	80KQL/W43-60-15/2	80/220-15/2	79	125KQL/W138-38-22/2	125/170-22/2
32	80KQL/W47-70-18.5/2	80/235-18.5/2	80	125KQL/W150-44-30/2	125/185-30/2
33	80KQL/W50-80-22/2	80/250-22/2	81	125KQL/W160-50-37/2	125/200-37/2
34	80KQL/W40-85-22/2	80/270-22/2	82	125KQL/W138-60-37/2	125/220-37/2
35	80KQL/W43-101-30/2	80/285-30/2	83	125KQL/W150-70-45/2	125/235-45/2
36	80KQL/W47-113-30/2	80/300-30/2	84	125KQL/W160-80-55/2	125/250-55/2
37	80KQL/W50-125-37/2	80/315-37/2	85	125KQL/W134-88-55/2	125/270-55/2
38	80KQL/W25-20-3/4	80/250-3/4	86	125KQL/W143-100-75/2	125/285-75/2
39	80KQL/W23-28-4/4	80/300-4/4	87	125KQL/W150-110-75/2	125/300-75/2
40	80KQL/W25-32-5.5/4	80/315-5.5/4	88	125KQL/W160-125-90/2	125/315-90/2
41	100KQL/W60-16-4/2	100/110-4/2(Z)	89	125KQL/W100-5-2.2/4	125/125-2.2/4
42	100KQL/W70-20-5.5/2	100/125-5.5/2(Z)	90	125KQL/W87-6-3/4	125/150-3/4
43	100KQL/W70-26-7.5/2	100/150-7.5/2(Z)	91	125KQL/W100-8-4/4	125/160-4/4
44	100KQL/W75-32-11/2	100/160-11/2(Z)	92	125KQL/W100-12.5-5.5/4	125/200-5.5/4
45	100KQL/W68-38-11/2	100/170-11/2(Z)	93	125KQL/W87-15-5.5/4	125/220-5.5/4
46	100KQL/W72-44-15/2	100/185-15/2(Z)	94	125KQL/W93-17-7.5/4	125/235-7.5/4
47	100KQL/W75-50-18.5/2	100/200-18.5/2(Z)	95	125KQL/W120-16-7.5/4	125/235(I)-7.5/4
48	100KQL/W89-10-4/2	100/90-4/2	96	125KQL/W100-20-11/4	125/250-11/4

## 与原型号对照表

序号	型号	原型号	序号	型号	原型号
97	125KQL/W79-20-7.5/4	125/285-7.5/4	145	200KQL/W340-24-30/4	200/285S-30/4
98	125KQL/W91-27-11/4	125/300-11/4	146	200KQL/W360-28-37/4	200/300S-37/4
99	125KQL/W100-32-15/4	125/315-15/4	147	200KQL/W390-32-45/4	200/315S-45/4
100	125KQL/W87-38-18.5/4	125/345-18.5/4	148	200KQL/W340-36-45/4	200/345S-45/4
101	125KQL/W94-44-22/4	125/370-22/4	149	200KQL/W370-40-55/4	200/350-55/4
102	125KQL/W100-50-30/4	125/400-30/4	150	200KQL/W374-44-75/4	200/370-75/4
103	150KQL/W140-20-11/4	150/250-11/4(Z)	151	200KQL/W400-50-75/4	200/400-75/4
104	150KQL/W160-24-15/4	150/285-15/4(Z)	152	200KQL/W346-60-90/4	200/410-90/4
105	150KQL/W150-28-18.5/4	150/300-18.5/4(Z)	153	200KQL/W374-70-110/4	200/435-110/4
106	150KQL/W160-32-22/4	150/315-22/4(Z)	154	200KQL/W400-80-132/4	200/460-132/4
107	150KQL/W138-38-22/4	150/345-22/4(Z)	155	250KQL/W490-17-30/4	250/235S-30/4
108	150KQL/W150-44-30/4	150/370-30/4(Z)	156	250KQL/W520-20-37/4	250/250S-37/4
109	150KQL/W160-50-37/4	150/400-37/4(Z)	157	250KQL/W500-25-45/4	250/290-45/4
110	150KQL/W179-10-11/4	150/185-11/4	158	250KQL/W500-28-55/4	250/300-55/4
111	150KQL/W200-12.5-11/4	150/200S-11/4	159	250KQL/W550-32-75/4	250/315-75/4
112	150KQL/W180-16-11/4	150/235S-11/4	160	250KQL/W500-41-75/4	250/350-75/4
113	150KQL/W200-20-15/4	150/250S-15/4	161	250KQL/W500-44-90/4	250/370-90/4
114	150KQL/W173-24-18.5/4	150/285-18.5/4	162	250KQL/W500-50-90/4	250/400S-90/4
115	150KQL/W200-28-22/4	150/290-22/4	163	250KQL/W480-60-132/4	250/410-132/4
116	150KQL/W200-32-30/4	150/315-30/4	164	250KQL/W515-70-160/4	250/435-160/4
117	150KQL/W240-32-30/4	150/315(I)-30/4	165	250KQL/W550-80-200/4	250/460-200/4
118	150KQL/W200-38-30/4	150/350-30/4	166	300KQL/W660-18-45/4	300-200A-45/4
119	150KQL/W187-44-37/4	150/370-37/4	167	300KQL/W720-20-55/4	300-200-55/4
120	150KQL/W200-50-45/4	150/400-45/4	168	300KQL/W600-24-55/4	300-315B-55/4
121	150KQL/W173-60-55/4	150/410-55/4	169	300KQL/W660-28-75/4	300-315A-75/4
122	150KQW180-70-55/2	KQW150/235-55/2	170	300KQL/W720-32-90/4	300-315-90/4
123	150KQL/W187-70-75/4	150/435-75/4	171	300KQL/W560-32-75/4	300-400C-75/4(N)
124	150KQW200-80-75/2	KQW150/250-75/2	172	300KQL/W600-38-90/4	300-400B-90/4(N)
125	150KQL/W200-80-75/4	150/460-75/4	173	300KQL/W660-44-110/4	300-400A-110/4(N)
126	200KQL/W280-10-11/4	200/185S-11/4(Z)	174	300KQL/W720-50-132/4	300-400-132/4(N)
127	200KQL/W300-12.5-15/4	200/200S-15/4(Z)	175	300KQL/W620-60-160/4	300-500B-160/4
128	200KQL/W280-16-18.5/4	200/235-18.5/4(Z)	176	300KQL/W670-70-200/4	300-500A-200/4
129	200KQL/W300-20-22/4	200/250S-22/4(Z)	177	300KQL/W720-80-250/4	300-500-250/4
130	200KQL/W245-24-22/4	200/285S-22/4(Z)	178	350KQL/W1000-24-110/4	350-315B-110/4
131	200KQL/W280-28-30/4	200/300S-30/4(Z)	179	350KQL/W1100-28-132/4	350-315A-132/4
132	200KQL/W300-32-37/4	200/315S-37/4(Z)	180	350KQL/W1200-32-160/4	350-315-160/4
133	200KQL/W260-38-45/4	200/345-45/4(Z)	181	350KQL/W820-24-90/4	350-315B-90/4(Z)
134	200KQL/W270-44-45/4	200/370S-45/4(Z)	182	350KQL/W860-28-110/4	350-315A-110/4(Z)
135	200KQL/W300-48-55/4	200/400S-55/4(Z)	183	350KQL/W960-32-132/4	350-315-132/4(Z)
136	200KQL/W262-60-75/4	200/410-75/4(Z)	184	350KQL/W1050-38-160/4	350-400B-160/4(N)
137	200KQW262-70-75/2	KQW200/235-75/2	185	350KQL/W1130-44-200/4	350-400A-200/4(N)
138	200KQL/W280-70-90/4	200/435-90/4(Z)	186	350KQL/W1200-50-250/4	350-400-250/4(N)
139	200KQW290-80-90/2	KQW200/250-90/2	187	350KQL/W820-38-132/4	350-400B-132/4(Z)(N)
140	200KQL/W300-80-110/4	200/460-110/4(Z)	188	350KQL/W860-44-160/4	350-400A-160/4(Z)(N)
141	200KQL/W358-10-15/4	200/185S-15/4	189	350KQL/W960-50-200/4	350-400-200/4(Z)(N)
142	200KQL/W400-12.5-18.5/4	200/200S-18.5/4			
143	200KQL/W358-16-22/4	200/235-22/4			
144	200KQL/W400-20-30/4	200/250-30/4			